

**You have downloaded a manual for our  
Model 50514-EC Ironworker. This  
manual does not include all of the  
optional tooling for this machine. If  
you would like a tooling manual, please  
download our #20 Tooling Manual.**

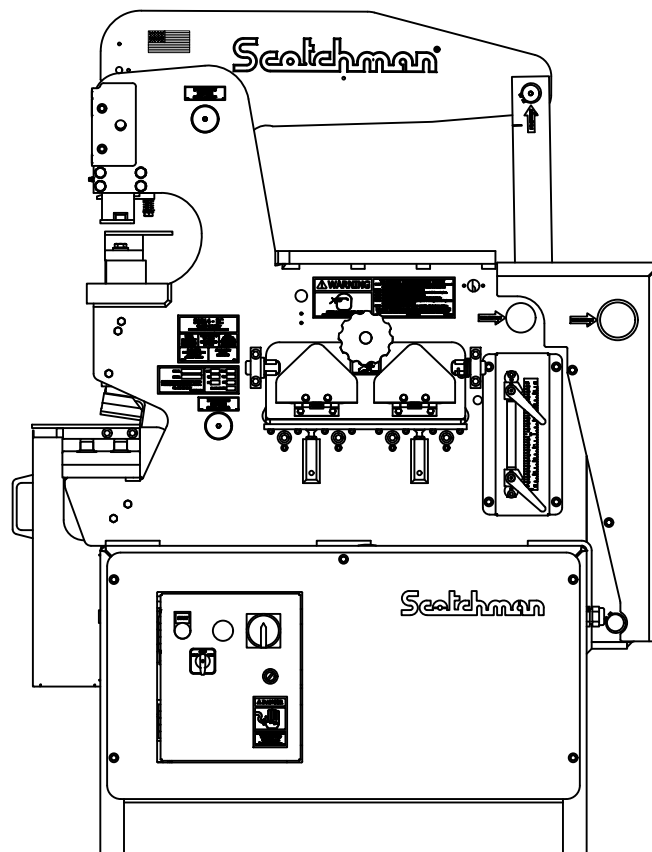



[www.scotchman.com](http://www.scotchman.com)

**MODEL  
50514-EC  
IRONWORKER**

S/N 5100EC0422 and up

**PRINTED - DECEMBER 2024**

# TABLE OF CONTENTS

<b>SECTION</b>	<b>DESCRIPTION</b>	<b>PAGE #</b>
<b>1.0</b>	<b>INTRODUCTION</b>	<b>4</b>
<b>2.0</b>	<b>SAFETY PRECAUTIONS</b>	<b>4</b>
<b>2.1</b>	<b>WARRANTY</b>	<b>5</b>
<b>3.0</b>	<b>WARNING LABELS</b>	<b>6</b>
<b>4.0</b>	<b>INSTALLATION &amp; SET UP</b>	<b>8</b>
<b>4.1</b>	<b>Physical Dimensions</b>	<b>8</b>
<b>4.2</b>	<b>Physical Dimensions</b>	<b>10</b>
<b>4.3</b>	<b>Physical Inspection</b>	<b>10</b>
<b>4.4</b>	<b>Electrical Requirements</b>	<b>12</b>
<b>4.5</b>	<b>Machine Start-up</b>	<b>16</b>
<b>4.6</b>	<b>Punch Up Adjustment</b>	<b>16</b>
<b>4.7</b>	<b>Punch Down Adjustment</b>	<b>18</b>
<b>4.7A</b>	<b>Alternative Stroke Adjustment Procedure</b>	<b>20</b>
<b>5.0</b>	<b>MAINTENANCE</b>	<b>22</b>
<b>5.1</b>	<b>Lubrication</b>	<b>22</b>
<b>5.2</b>	<b>Scheduled Maintenance</b>	<b>24</b>
<b>6.0</b>	<b>MACHINE OPERATION</b>	<b>26</b>
<b>6.1</b>	<b>Punch Operation</b>	<b>26</b>
<b>6.2</b>	<b>Angle Shear</b>	<b>32</b>
<b>6.3</b>	<b>Bar Shear Operation</b>	<b>36</b>
<b>6.3A</b>	<b>Bar Shear Arm Adjustment</b>	<b>38</b>
<b>6.3B</b>	<b>Bar Shear Blade Adjustment Procedure</b>	<b>40</b>
<b>6.4</b>	<b>Rectangle Notcher Operation</b>	<b>42</b>
<b>6.5</b>	<b>Optional Jog Control</b>	<b>44</b>
<b>7.0</b>	<b>OPTIONAL TOOLS</b>	<b>46</b>
<b>7.1</b>	<b>Rod Shear</b>	<b>46</b>
<b>7.2</b>	<b>Six Inch Brake</b>	<b>48</b>
<b>7.3</b>	<b>Eight Inch Brake &amp; Twelve Inch Brake</b>	<b>50</b>
<b>7.4</b>	<b>6 x 6 Ninety Degree Notcher</b>	<b>52</b>
<b>7.5</b>	<b>Pipe Notcher</b>	<b>54</b>
<b>7.6</b>	<b>Picket Fence Tool</b>	<b>58</b>

# TABLE OF CONTENTS

<b>SECTION</b>	<b>DESCRIPTION</b>	<b>PAGE #</b>
7.7	Square Tube Shear	60
7.7A	Square Tube Shear Installation	60
7.7B	Square Tube Shear Operation	60
7.7C	Angle Iron Brake Installation	60
7.7D	Angle Iron Brake Operation	60
7.7E	Multi- Shear Tool	62
7.7F	Weld Coupon Bender Tool	64
7.8	Optional Die Holders and Strippers	66
7.9	Optional Gauging Equipment	66
7.9A	48 Inch Back Gauge	66
7.9B	Gauging Table-Bar Shear	66
7.9C	Angle Miter Guide	66
8.0	<b>TROUBLE SHOOTING GUIDE</b>	68
8.1	Electrical-Motor	68
8.2	Limit Switch Inspection	69
8.3	Control Valve Inspection	69
8.4	Hydraulic	70
8.5	Cylinder Seal Replacement	70
9.0	<b>MACHINE PARTS LISTS</b>	72
9.1	Punch Assembly	72
9.2	Shear Assembly	74
9.3	Electric Stroke Control Assembly	76
9.3A	Electric Stroke Valve & Manifold	78
9.4	Hose & Fitting Locations	80
9.4A	Power Unit	82
9.5	Electrical Controls	84
9.6	4 x 4 Angle Shear	86
9.7	Notcher Assembly	88
9.8	Sheet Metal	90
9.9	Cylinder	92
9.10	Hold Down Assembly	94
9.11	Optional Jog Control	96
10.0	<b>ELECTRICAL SCHEMATICS</b>	98
11.0	<b>HYDRAULIC SCHEMATIC</b>	104

## **1.0 INTRODUCTION**

The Scotchman Ironworker is a versatile, multi-purpose, shearing, punching and forming machine engineered for trouble free operation. The design of the machine combines simplicity of operation with smooth, full stroke control.

The ability of the operator to control the machine's direction of movement at any point in the stroke, (i.e. stop, jog or reverse) gives the Scotchman Ironworker a tremendous advantage over mechanical ironworkers. There is no chance of the Scotchman Ironworker being accidentally tripped.

The hydraulic system operates at a maximum pressure of 2,350 PSI (162 BAR) and is protected from overload by a built-in relief valve.

## **2.0 SAFETY PRECAUTIONS**

- 1. The operators of this machine must be qualified and well trained in the operation of the machine. The operators must be aware of the capacities of the machine and the proper use of the hold down devices, strippers and guards provided with the machine.**
- 2. All of the guards, adjustable restrictors and awareness barriers must be installed on the machine and kept in good working order. Promptly replace worn or damaged parts with authorized parts.**
- 3. Never place any part of your body into or under any of the machine's moving parts, strippers or hold devices.**
- 4. Wear the appropriate personal protective equipment. Safety glasses are required at all times, whether operating, setting up or observing this machine in operation. Since heavy pieces of metal with sharp edges can be processed on this machine, the operators should also wear steel-toed shoes and tight fitting leather gloves.**
- 5. Strictly comply with all warning labels and decals on the machine. Never remove any of the labels. Replace worn or damaged labels promptly.**
- 6. Always disconnect and lock out the power when performing maintenance work or setting up any tooling on the machine. Follow the procedures outlined in the operator's manual for setting up, changing or aligning any tooling on this machine.**
- 7. Never operate this machine with dull or damaged tooling. Promptly replace worn punches, dies and blades.**
- 8. Practice good housekeeping. Keep the area around the machine clear and well lit. Do not obstruct the operator's position by placing anything around the machine that would impede the operator's access to the machine.**

9. **Never modify this machine in any way without the written permission of the manufacturer.**
10. **Never leave this machine running unattended.**
11. **Always operate the flat bar shear and tooling station from the operator's side (the side the electrical control is mounted on). Always operate the punch and notching station facing the station.**
12. **Set up a program of routine inspections and maintenance for this machine. Make all repairs and adjustments in accordance with the manufacturer's instructions.**
13. **A safety DVD was mailed to you or shipped with the machine. If you did not receive it, please contact the factory or your local dealer, immediately, and one will be sent to you at no charge.**

## **2.1 WARRANTY**

**Scotchman Industries, Inc. will, within three years of the date of purchase, replace F.O.B. the factory or refund the purchase price for any goods which are defective in materials or workmanship, provided the buyer, at the seller's option, returns the defective goods freight and delivery prepaid to the seller, which shall be the buyer's sole and exclusive remedy for defective goods.**

**This warranty does not apply to machines and/or components which have been altered, changed or modified in any way or subjected to abuse and abnormal use, inadequate maintenance and lubrication or subjected to use beyond the seller's recommended capacities and specifications.**

**In no event shall the seller be liable for labor cost expended on such goods or consequential damages.**

**The seller shall not be liable to the purchaser or any other person for loss or damage directly or indirectly arising from the use of the goods or from any other cause.**

**No officer, employee or agent of the seller is authorized to make any oral representations or warranty of fitness or to waive any of the foregoing terms of sale and none shall be binding on the seller.**

**Any electrical changes made to the standard machine due to local electrical code variation must be paid by purchaser. As we constantly strive to improve our products, we reserve the right to make changes without notification.**

**This warranty is effective December 1, 2009.**

### **3.0 WARNING LABELS**

<b>ITEM</b>	<b>QTY</b>	<b>PART#</b>	<b>DESCRIPTION</b>
<b>A</b>	<b>1</b>	<b>010115</b>	<b>15" Scotchman Decal</b>
<b>B</b>	<b>1</b>	<b>019127</b>	<b>U.S. Flag Decal</b>
<b>C</b>	<b>1</b>	<b>003105</b>	<b>Fingers Beyond Bar Guard</b>
<b>D</b>	<b>1</b>	<b>019145</b>	<b>50514EC Capacity Decal</b>
<b>E</b>	<b>1</b>	<b>003100</b>	<b>Large Safety Glasses</b>
<b>F</b>	<b>1</b>	<b>003162</b>	<b>5/16 Max Notcher</b>
<b>G</b>	<b>1</b>	<b>003122</b>	<b>Danger Voltage</b>
<b>H</b>	<b>1</b>	<b>003110</b>	<b>Punch &amp; Die Warning</b>
<b>I</b>	<b>2</b>	<b>019103</b>	<b>Decal "Lubricate"</b>
<b>J</b>	<b>3</b>	<b>019105</b>	<b>Decal "Grease Point"</b>
<b>K</b>	<b>2</b>	<b>003106</b>	<b>Fingers Sticker</b>
<b>L</b>	<b>1</b>	<b>019102</b>	<b>Decal "Reservoir Capacity"- Not Shown</b>
<b>M</b>	<b>1</b>	<b>003190</b>	<b>20K Punch Sticker</b>
<b>N</b>	<b>1</b>	<b>004085</b>	<b>Scale Stroke Control</b>
<b>O</b>	<b>1</b>	<b>003514</b>	<b>50514EC Decal Package</b>

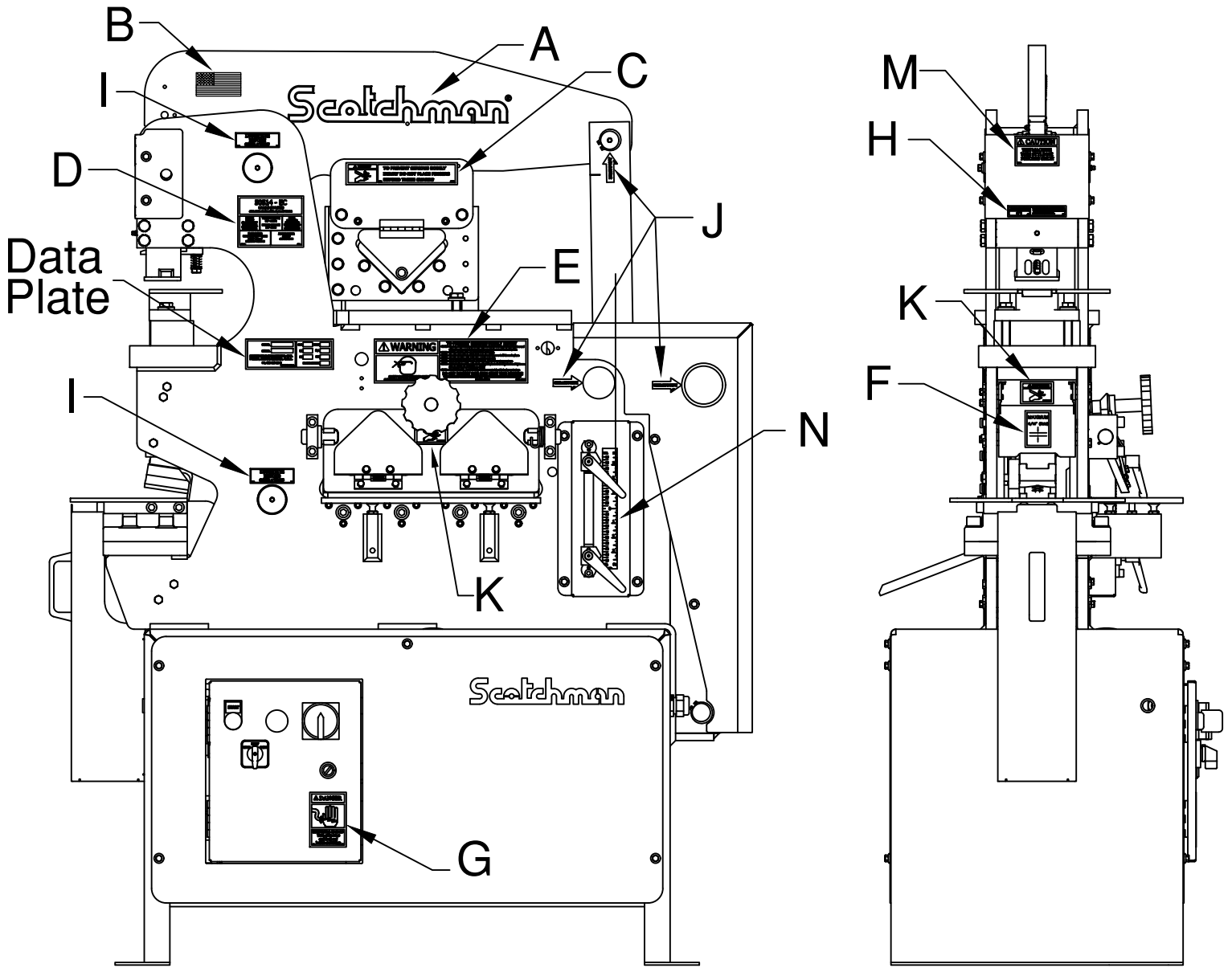

FIGURE 1



## 4.0 INSTALLATION AND SET-UP

**CAUTION: THIS SECTION DISCUSSES INSTALLATION AND SET-UP PROCEDURES.**

**PLEASE READ ALL SECTIONS OF THIS MANUAL THOROUGHLY BEFORE OPERATING THIS MACHINE.**

## 4.1 PHYSICAL DIMENSIONS

		<b>INCHES</b>	<b>CM</b>
<b>A</b>	<b>Floor To Top of Die Holder</b>	<b>46.28</b>	<b>117.55</b>
<b>B</b>	<b>Floor To Punch Bolster</b>	<b>43.64</b>	<b>110.84</b>
<b>C</b>	<b>Throat Depth</b>	<b>6</b>	<b>15.24</b>
<b>D</b>	<b>Floor To Bar Shear</b>	<b>32</b>	<b>81.28</b>
<b>E</b>	<b>Floor To Tool Table</b>	<b>44.83</b>	<b>113.87</b>
<b>F</b>	<b>Floor To Angle Shear</b>	<b>46.03</b>	<b>116.91</b>
<b>G</b>	<b>Floor To Notcher</b>	<b>31.97</b>	<b>81.20</b>
<b>H</b>	<b>Punch Stroke</b>	<b>1.25</b>	<b>3.17</b>
<b>I</b>	<b>Height</b>	<b>62.54</b>	<b>158.85</b>
<b>J</b>	<b>Length</b>	<b>48.18</b>	<b>122.38</b>
<b>K</b>	<b>Width</b>	<b>23.46</b>	<b>59.59</b>
<b>L</b>	<b>Weight</b>	<b>1,570 LBS</b>	<b>712.14 KG</b>

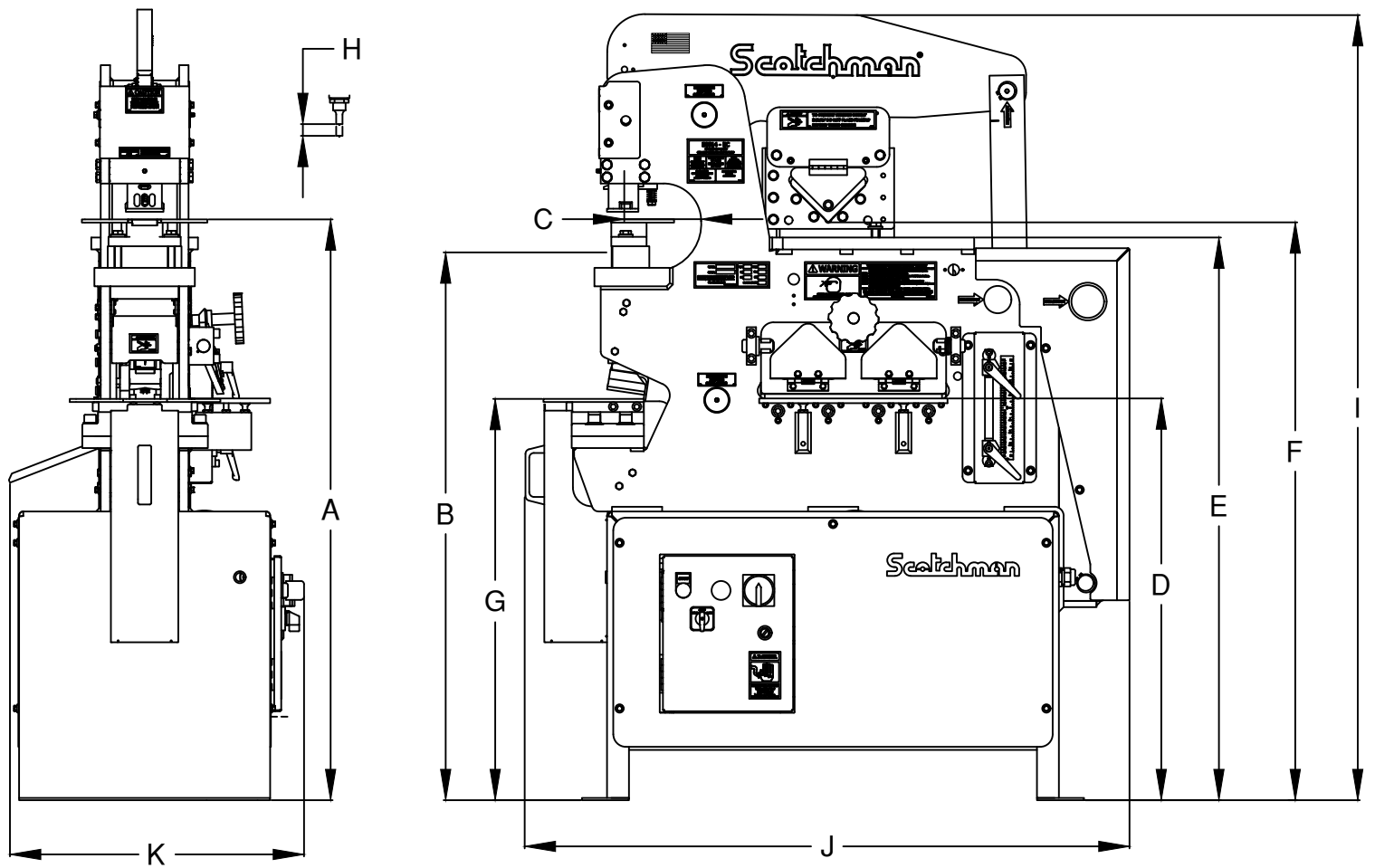

FIGURE 2

## **4.2 MACHINE MOVING PROCEDURE**

- ☒ CAUTION: BE SURE THAT ANY LIFTING DEVICE HAS ADEQUATE CAPACITY BEFORE ATTEMPTING TO MOVE THIS MACHINE.**

The weight of this machine is 1,570 pounds (671.3 KG).

**FIGURE 3 ON THE FOLLOWING PAGE DEMONSTRATES THE USE OF AN OVERHEAD LIFT OR A FORK LIFT.**

These are the only two recommended methods of moving this machine.

When using a fork lift, spread the forks of the lift so that they are towards the outside and next to the legs of the machine.

- ☒ USE EXTREME CAUTION WHEN MOVING THIS MACHINE WITH A FORKLIFT. KEEP IT LEVEL AND MAKE NO SUDDEN STARTS OR STOPS.**

Do not back away from the machine with the forks tilted up.

This may cause damage to the interior components of the machine.

This machine does not have to be anchored to the floor to operate.

## **4.3 PHYSICAL INSPECTION**

Any damage to the machine during shipment should be reported to the delivery carrier immediately and a damage report made out so that a claim can be placed. The carrier is responsible for shipping damage, but it is the customer's responsibility to report damages, external or internal, immediately.

After the machine has been positioned, the shroud on the operator's side should be removed and an inspection made of the interior for missing or damaged parts.

**CHECK SPECIFICALLY:**

- 1. Check all fasteners, especially on the motor and pump, to be sure that they are tight.**
- 2. Check the motor base for any damage.**
- 3. Check the re-pack box for all accessory items ordered with the machine.**

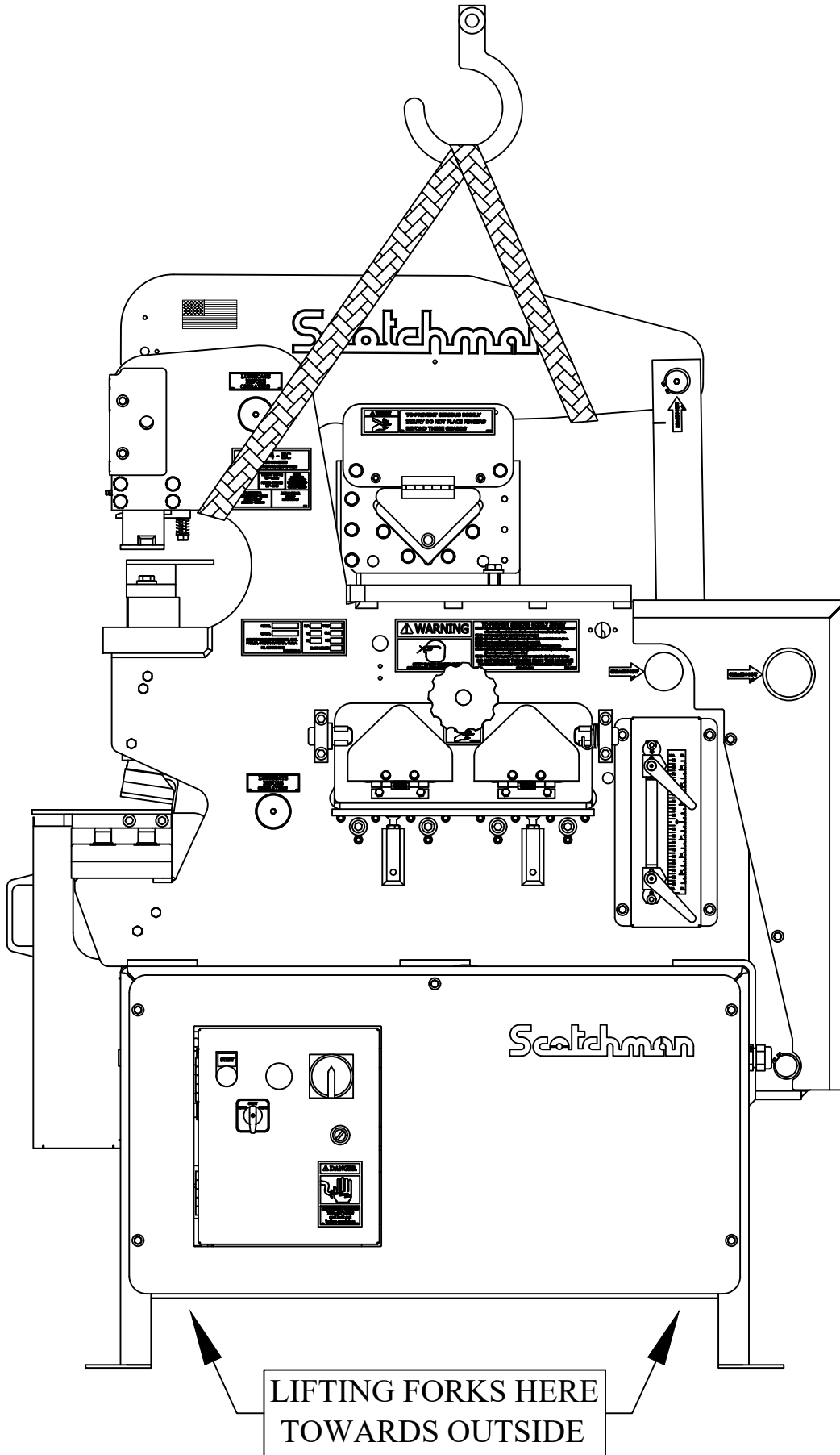

FIGURE 3

## 4.4 ELECTRICAL REQUIREMENTS

⊗ **CAUTION: TO PREVENT DAMAGE TO THE MOTOR AND DANGER TO THE OPERATOR, ALL ELECTRICAL CONNECTIONS SHOULD BE MADE BY A LICENSED ELECTRICIAN.**

For supply lines ten feet (3 m) or shorter, we recommend at least 12 gauge, and preferably 10 gauge, wire. For longer lines, use at least 10 gauge, and preferably, 8 gauge. We do not recommend supply lines longer than twenty five feet (7.6 m).

All machines are wired for three phase power unless otherwise specified. Check the motor data tag for full load current requirements. The supply voltage should be (+ or -) ten (10) percent of the motor voltage rating, to insure satisfactory machine performance.

**THE STARTER WIRING DIAGRAM IS IN FIGURE 4 ON THE FOLLOWING PAGE.**

Three phase motors are dual voltage and can be rewired for either 230 or 460 voltage. The wiring diagram is on the motor. The starters are not dual voltage and the overload must be exchanged when making a voltage change.

**FOR PARTS INFORMATION, SEE SECTION 10.8.**

<b>MOTOR VOLTAGE</b>	<b>FULL LOAD CURRENT</b>	
<b>208 V/3 PH</b>	<b>10.6 Amps</b>	
<b>230 V/3 PH</b>	<b>10 Amps</b>	
<b>460 V/3 PH</b>	<b>5 Amps</b>	
<b>220 V/1 PH</b>	<b>21 Amps</b>	
<b>Motor frame:</b>	<b>3PH-182T</b>	<b>1PH-184T</b>
<b>Motor power rating:</b>	<b>3PH-3HP</b>	<b>1PH-5HP</b>
<b>Speed:</b>	<b>1,740 RPM</b>	
<b>KVA power rating:</b>	<b>5.6 KVA</b>	
<b>Frequency:</b>	<b>60 HZ</b>	
<b>Starting current:</b>	<b>210% of Full Load</b>	

**MOTOR CONNECTIONS**

**HIGH VOLTAGE CONNECTION  
( 440-480 VOLT 3PH )**

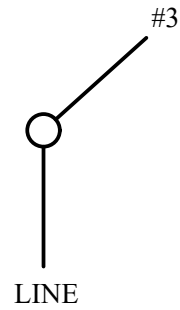
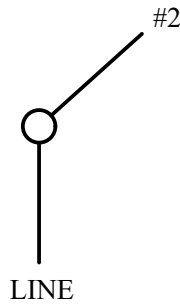
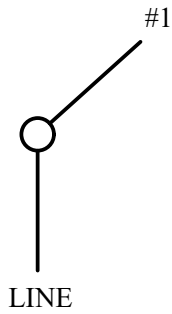
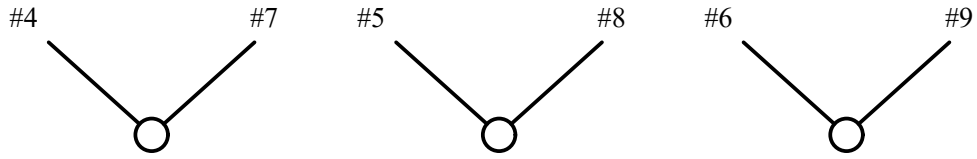

#1 thru #9 are Wires  
From the Motor

**LOW VOLTAGE CONNECTION  
( 220-240 VOLT 3PH )**

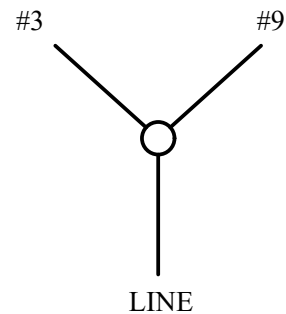
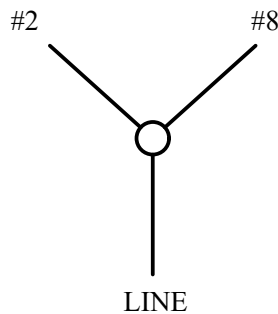
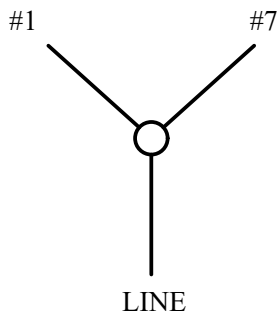
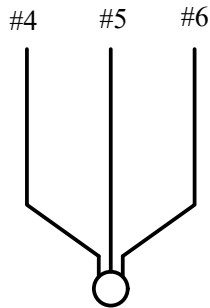

**FIGURE 4A**

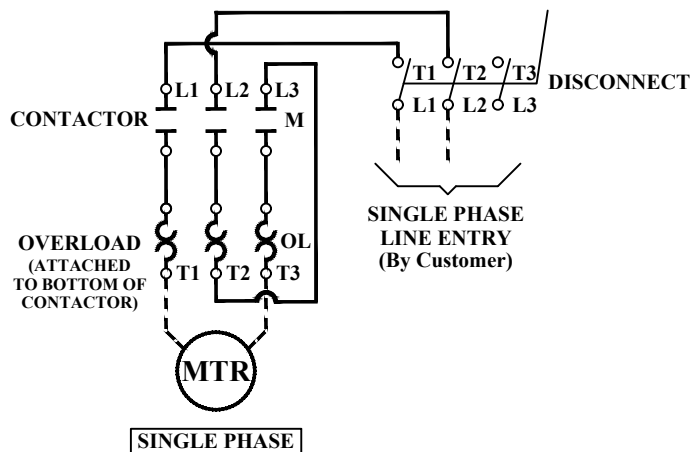
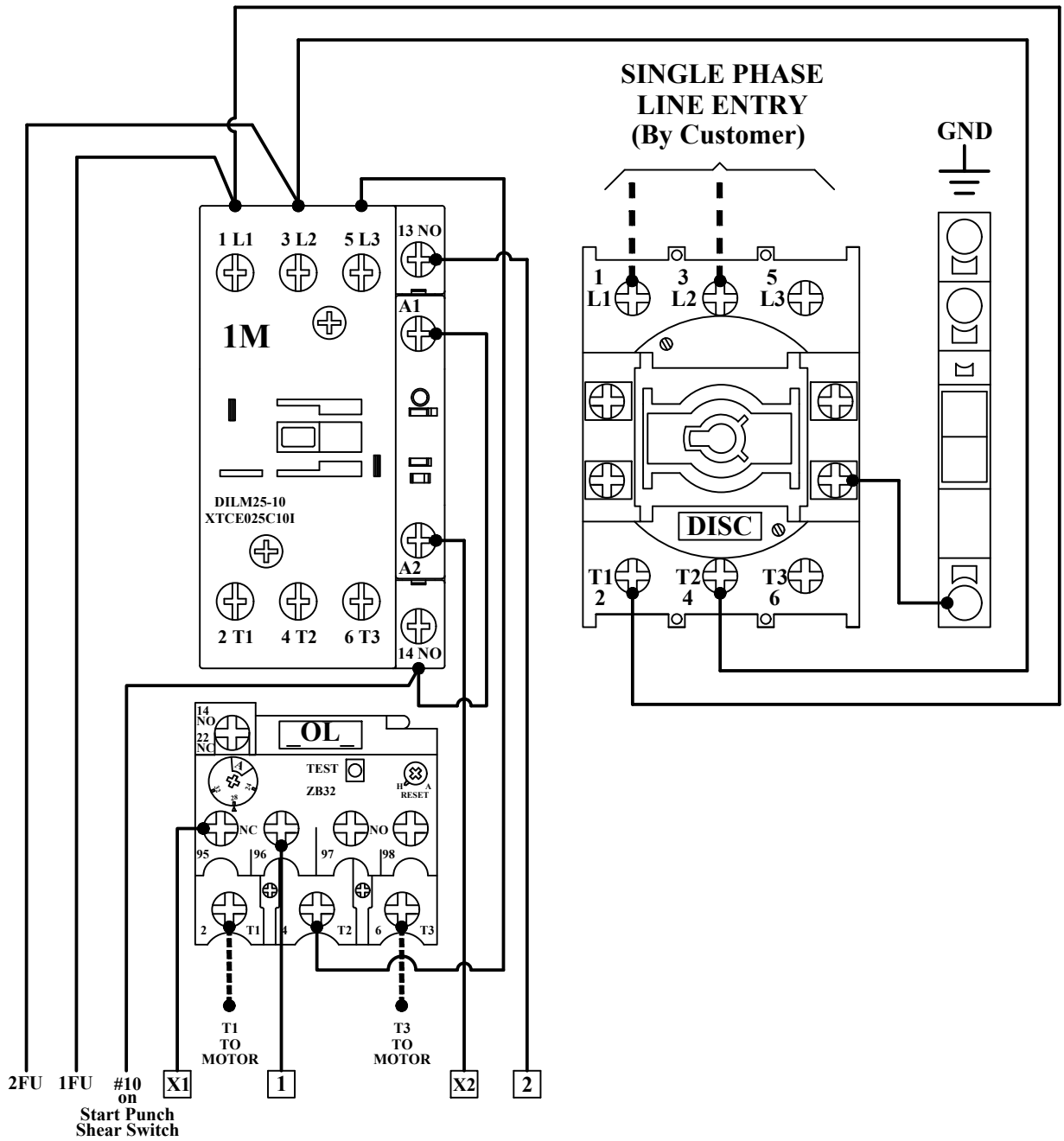

**FIGURE 4B**

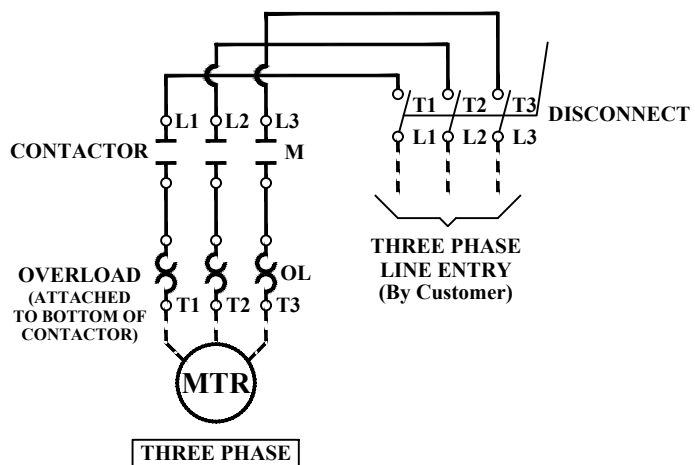
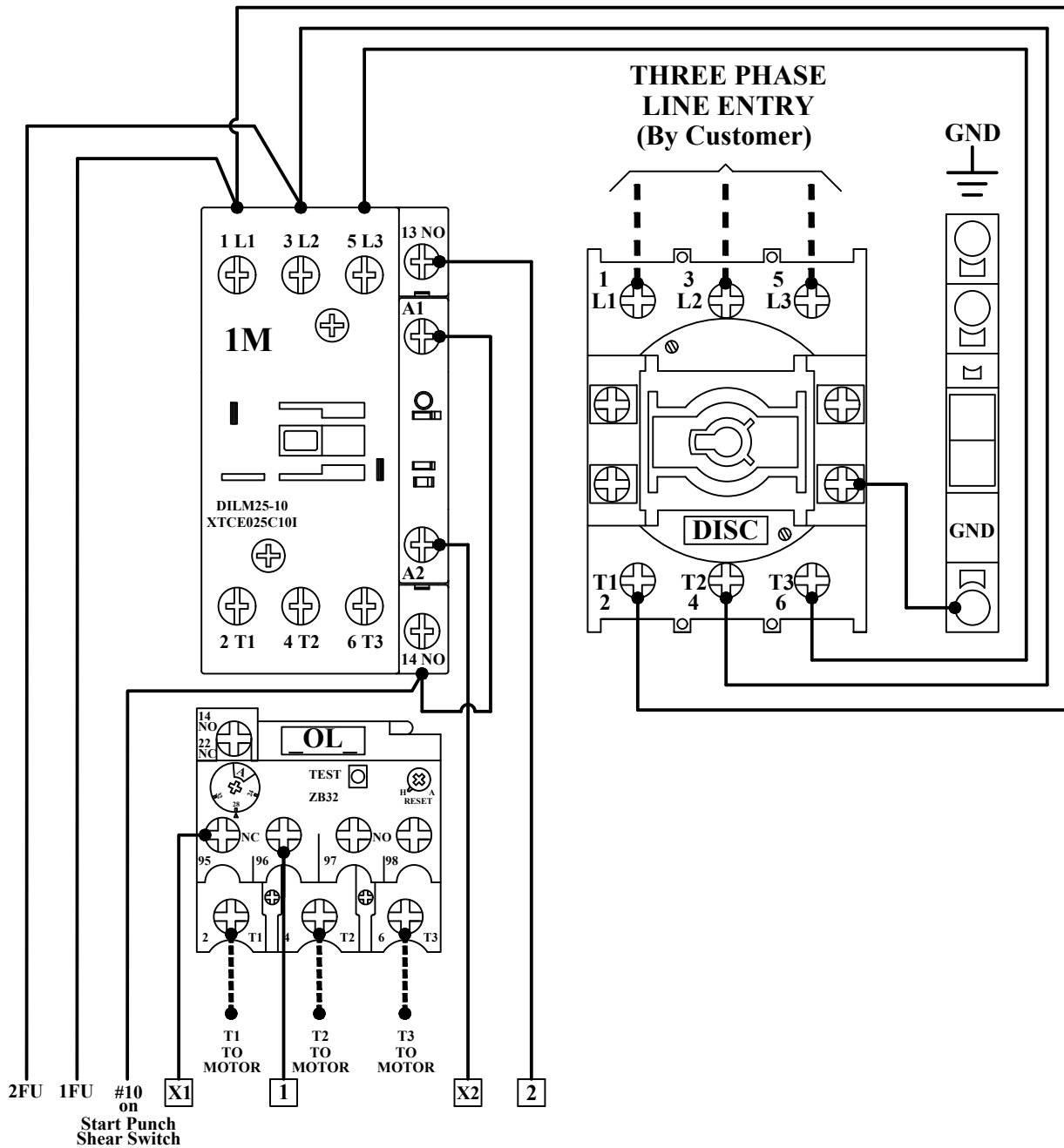

FIGURE 4C



## **4.5 MACHINE START-UP**

Before starting this machine, take time to thoroughly review the safety CD and the operator.s manual. This machine is equipped with a lock-out, disconnect switch. We strongly urge you to follow the OSHA directive CFR-1910.147 (effective 09-01-90) regarding lock-out, tag-out procedures. Before powering the machine, be sure that all packing materials and tools have been removed from the machine and that all work stations are clear. To power the machine, place the Disconnect Switch (A) in the ON position. Make sure the Selector Switch (C) is in the START position. Power the machine by pressing the green START button (D). Put the Selector Switch (C) in PUNCH mode. Step on the foot pedal. If the machine is running but will not move, the electrician will have to switch two of the three line wires. Once the machine is powered correctly, it will travel to where the Selector Switch (C) is turned to. Placing the Selector Switch in the PUNCH position will cause the arm to move down and the shear to close. Placing the Selector Switch in the SHEAR position will cause the arm to move up and the shear to open.

- ▶ **NOTE:** The Selector Switch (C) must be in the START position for the machine to start.

## **4.6 PUNCH UP ADJUSTMENT**

SEE FIGURE 5 ON THE FOLLOWING PAGE.

- ▶ **NOTE:** This procedure is to make sure that the machine has the full and correct amount of stroke.
1. Remove all punches, if any have been installed.
  2. Place the Disconnect Switch (A) in the OFF position.
  3. Place the stroke control handles (F) in their outermost positions..
  4. Place the Selector Switch (C) in the START position. Place the Disconnect Switch (A) in the ON position. Push the green START button (D) to power the machine.
  5. Place the Selector Switch (C) in the PUNCH position and allow the punch barrel to reach its highest point. Turn OFF the machine by pushing the Emergency Stop Button (B).
  6. Measure the distance from the top of the tool table to the center of the DIVOT in the punch beam.
  7. When the DIVOT measurement is other than 11-3/4" (298mm):
    - A. Place the Selector Switch (C) in the SHEAR position and allow the punch barrel to reach its lowest point. Turn OFF the machine by pushing the Emergency Stop Button (B).
    - B. Loosen the lower stroke adjustment handle (F) and move up about halfway.
    - C. Loosen the bolt (E) and adjust the travel by moving the bottom stop DOWN if the DIVOT measurement is over 11-3/4" (298mm) and UP if the DIVOT measurement is under 11-3/4" (289mm) . Do not move the bottom stop more than 1/8" (3mm) for each adjustment.
    - D. Move the lower stroke adjustment handle (F) down to the stop.
    - E. Power up the machine and repeat, starting at Step 5 until DIVOT measurement is correct.

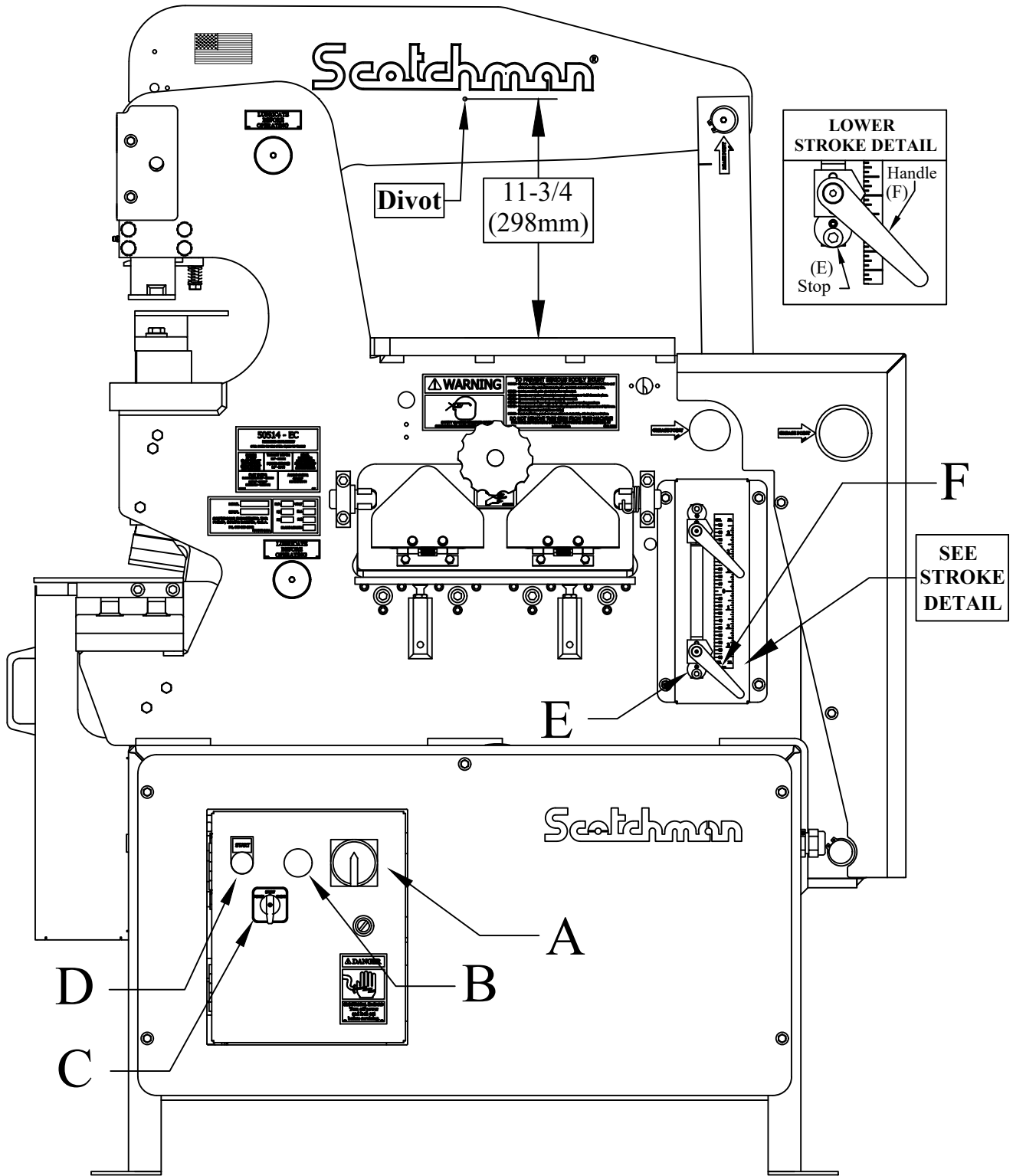

FIGURE 5

## **4.7 PUNCH DOWN ADJUSTMENT**

**SEE FIGURE 6 ON THE FOLLOWING PAGE.**

▶ **NOTE: This procedure is to make sure that the machine has the full and correct amount of stroke.**

- 1. Remove the punch, if one has been installed.**
- 2. Place the Disconnect Switch (A) in the OFF position.**
- 3. Place the stroke control handles (F) in their outermost positions..**
- 4. Place the Selector Switch (C) in the START position.**  
**Place the Disconnect Switch (A) in the ON position.**  
**Push the green START button (D) to power the machine.**
- 5. Place the Selector Switch (C) in the SHEAR position and allow the punch barrel to reach its lowest point. Turn OFF the machine by pushing the Emergency Stop Button (B).**
- 6. Measure the distance from the top of the tool table to the center of the divot in the punch beam.**  
**This measurement should be 13-13/16" (351mm).**

**When measurement is other than 13-13/16" (351mm):**

- A. Place the Selector Switch (C) in the PUNCH position and allow the punch barrel to reach its highest point. Turn OFF the machine by pushing the Emergency Stop Button (B).**
- B. Loosen the upper stroke adjustment handle (F) and move down about halfway.**
- C. Loosen the bolt (E) and adjust the measurement by moving the upper stop UP if the measurement is too small and DOWN if the measurement is too large. Do not move the stop more than 1/8" (3mm) for each adjustment.**
- D. Power up the machine and repeat, starting at Step 6 until the measurement is corrected.**

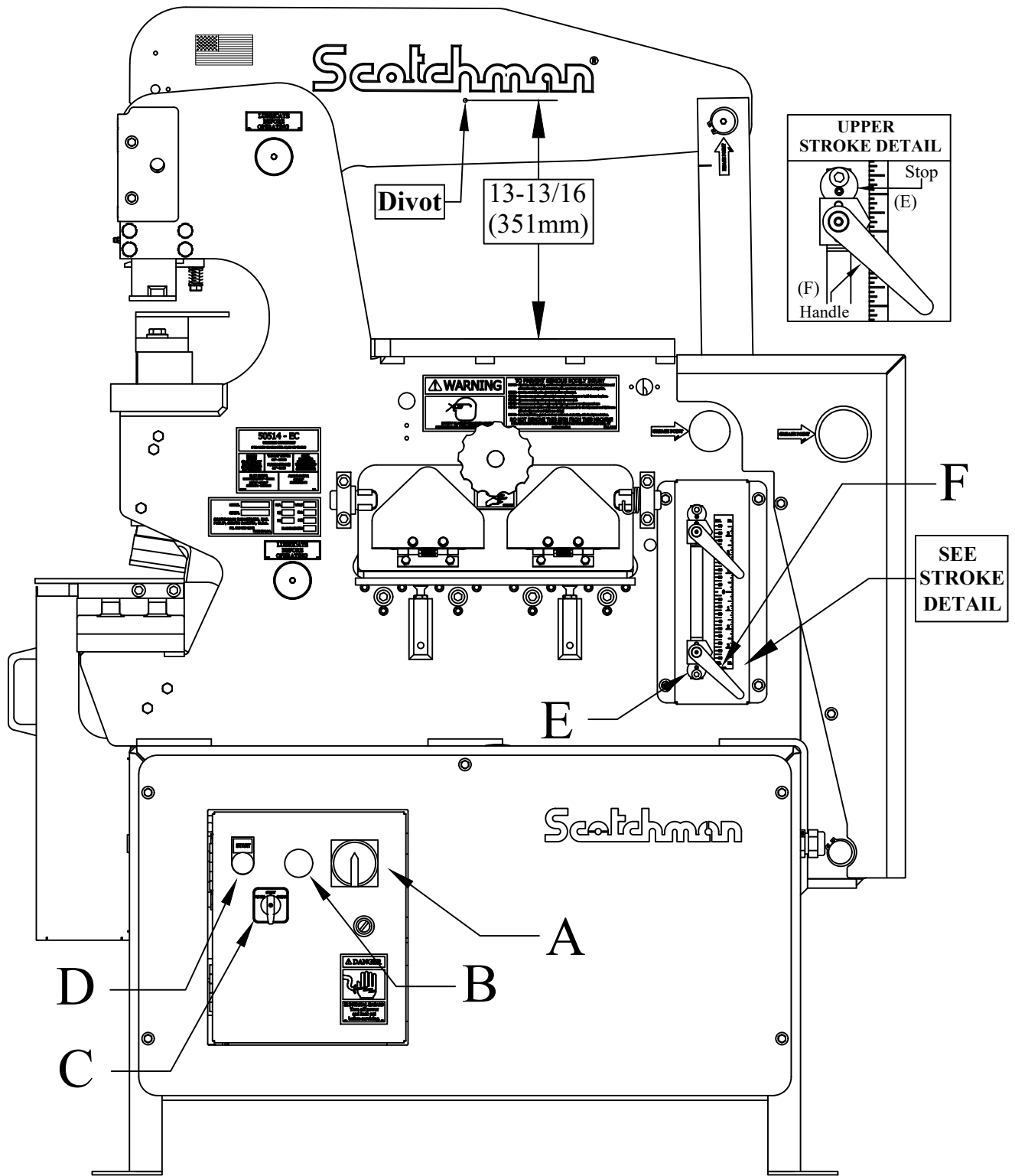

FIGURE 6

## **4.7A ALTERNATIVE STROKE ADJUSTMENT PROCEDURE**

SEE FIGURE 6A.

- ▶ **NOTE:** The alternative method can also be used to make sure that the machine has the correct amount of stroke. It is directly measuring the up and down positions of the cylinder.

### **CYLINDER DOWN MEASUREMENT**

1. Remove all punches, if any have been installed.
2. Place the Disconnect Switch (A) in the OFF position.
3. Remove the four M-8 x 16mm bolts (two on each side) from the cylinder shroud and remove the shroud.
4. Place the stroke control handles (F) in their outermost positions.
5. Place the selector switch (C) in the START position. Place the disconnect switch (A) in the ON position. Push the green START button (D) to power the machine.
6. Place the Selector Switch (C) in the PUNCH position and allow the punch beam to reach its lowest point. Turn off the machine by pushing the Emergency Stop Button (B).
7. Measure from the BOTTOM of the bottom pin to the grease zerk in the CENTER of the top pin. It should measure 17-1/8" (435mm).

**IF IT MEASURES ANYTHING OTHER THAN 17-1/8 INCHES (435mm):**

- A. Place the Selector Switch (C) in the SHEAR position and allow the punch beam to reach its highest point. Turn the machine OFF by pushing the Emergency Stop Button (B).  
**SEE LOWER STROKE DETAIL**
- B. Loosen the Lower Stroke Adjustment Handle (F) and move up about halfway.
- C. Loosen the bolt (E) and adjust the travel by moving the bottom Stop UP if the measurement is LESS than 17-1/8" (435mm) and DOWN if it measures MORE than 17-1/8" (435mm) Do not move the bottom stop more than 1/8" (3mm) for each adjustment.
- D. Move the Lower Stroke Adjustment Handle (F) down to the Stop.
- E. Power up the machine and repeat, starting with Step 6, until measurement is 17-1/8" (435mm).

### **CYLINDER UP MEASUREMENT**

1. With the stroke control handles (F) in their outermost positions, place the Selector Switch (C) in the START position and place the Disconnect Switch (A) in the ON position. Push the green START button (D) to power the machine.
2. Place the Selector Switch (C) in the SHEAR position and allow the punch beam to reach its highest point. Turn off the machine by pushing the Emergency Stop Button (B).
3. Measure from the BOTTOM of the bottom pin to the grease zerk in the CENTER of the top pin It should measure 23-1/4" (591mm).

**IF IT MEASURES ANYTHING OTHER THAN 23-1/4 INCHES (591mm):**

- A. Place the Selector Switch (C) in the PUNCH position and allow the punch beam to reach its lowest point. Turn off the machine by pushing the Emergency Stop Button (B).  
**SEE UPPER STROKE DETAIL.**
- B. Loosen the Upper Stroke Adjustment Handle (F) and move down about halfway.

- C. Loosen the bolt (E) and adjust the travel by moving the upper Stop UP if the measurement is LESS than 23-1/4" (591mm) and DOWN if it measures MORE than 23-1/4" (591mm). Do not move the bottom Stop more than 1/8" (3mm) for each adjustment.
- D. Move the upper Stroke Adjustment Handle (F) up to the Stop.
- E. Power up the machine and repeat, starting with Step 2 until the measurement is 23-1/4" (591mm).

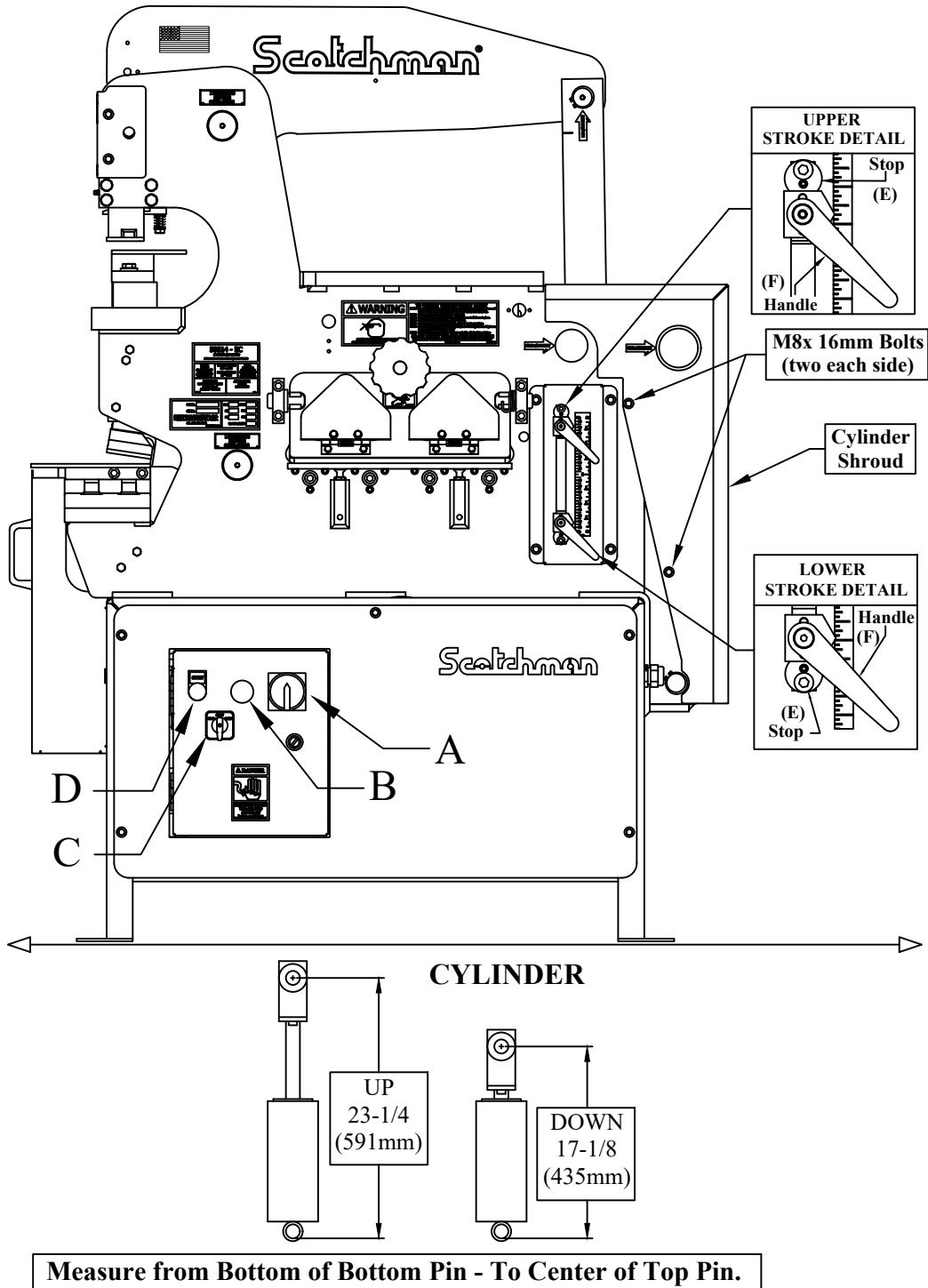

FIGURE 6A

## **5.0 MAINTENANCE**

The Scotchman Ironworker is an exceptionally rugged machine, designed for long life with a minimum amount of maintenance. A regular program of servicing will extend machine life and prevent costly downtime.

### **5.1 LUBRICATION**

➡ **IMPORTANT:** Before operating the 50514-EC Ironworker, apply oil to the bar shear blades, angle shear blades, notcher blades and the punch and die.

Re-oil the punch and die every 5 to 10 holes and the blades every 10 to 15 cuts.

The oil will allow the machine to shear, punch and strip easier and increase tool life considerably.

We recommend cutting oil or motor oil swabbed on with a small brush or applied with a squirt can or spray applicator. Grease the main pins (A & B) and the punch barrel (C) daily.

**SEE FIGURE 7 ON THE FOLLOWING PAGE.**

A multi-purpose, Molybdenum Disulfide, high pressure, bearing grease, MOBIL XHP 222 or equivalent, is the recommended grease for this machine.

Grease the main pins (A & B) and the punch barrel (C) daily.

Grease the angle shear pressure block and guides (F) twice daily when the tool is in use.

Once a week, apply grease to the surface of the beam guide wear plates (D) on the outer end of the shear beam.

Grease all other fittings (E) twice per week.

Check the level in the reservoir once a month. It is necessary to remove the front shroud to gain access to the reservoir filler breather cap.

To check the oil level, remove the filler breather cap and measure the depth of the oil in the reservoir. The fluid level should be 1 inch below the top of the reservoir.

There is an access hole in the top of the machine's base, right above the fill hole in the reservoir, to facilitate checking and adding of hydraulic oil to the reservoir.

The recommended hydraulic fluid is MOBIL DTE-24 or equivalent.

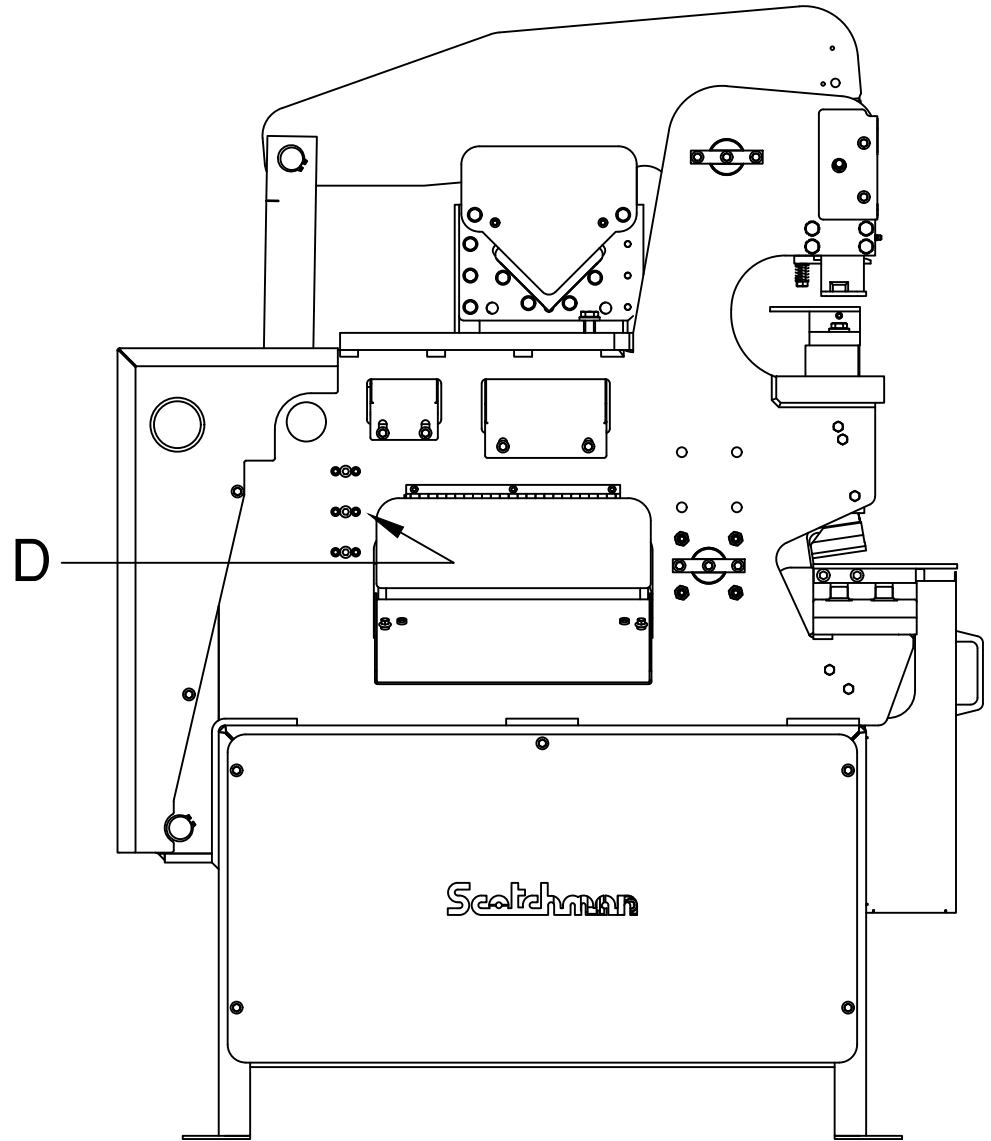
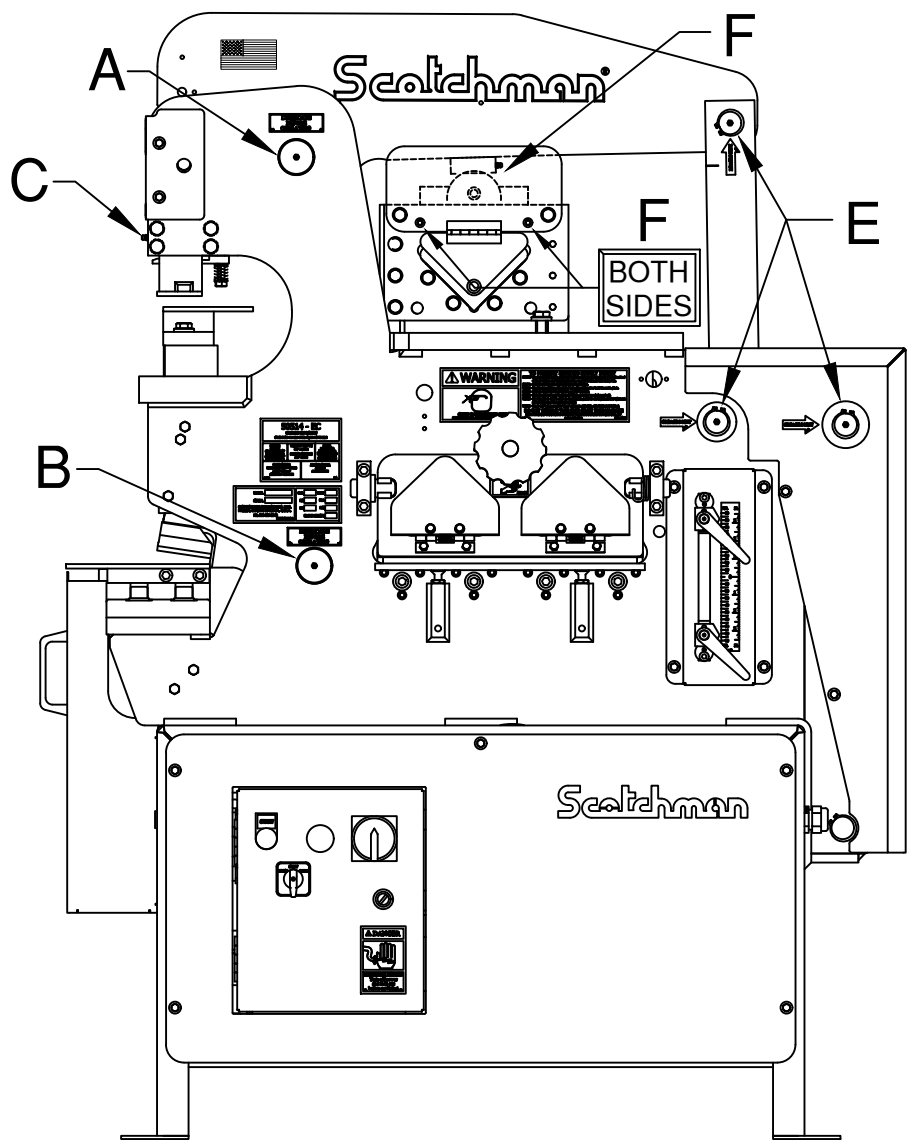

FIGURE 7



## **5.2 SCHEDULED MAINTENANCE**

A program of scheduled maintenance should be set up and documented according to your application and the frequency you use this machine. The following is a list of important items that should be included in a scheduled maintenance program:

☒ **NOTE: AFTER THE FIRST 50 HOURS OF OPERATION, CHECK THE STROKE OF THE MACHINE. REFER TO SECTIONS 4.6 AND 4.7 FOR THIS.**

### **1. EVERY 250 HOURS OR THREE MONTHS:**

**A. Check the clearance between the punch barrel (A) and the punch barrel guide (B). FOR PARTS IDENTIFICATION, SEE FIGURE 8 ON THE FOLLOWING PAGE.**

#### **TO CHECK THE CLEARANCE:**

- 1. With a punch and die properly installed following the instructions in SECTION 6.1, place the selector switch in the SHEAR position.**
- 2. With the punch in the die, jog the machine with the foot pedal, watching for lateral movement of the punch in the die.**
- 3. If lateral movement is noted, turn the machine's power off. Remove the punch barrel (A) and punch barrel guide (B) from the machine and check the tolerance between the two parts.**
- 4. If the tolerance exceeds three (.003) thousandths of an inch (.07mm), replace both parts.**
- 5. When replacing these parts, do not over tighten the drag link bolts (C). The bolts should be tight enough to restrict the punch barrel from rotating, but not so tight that they won't allow the drag links (D) to rotate as the arm travels down.**

### **2. EVERY 500 HOURS OR SIX MONTHS:**

**Check the condition of the shear blades, angle shear blades and any component tools for wear. Replace worn parts promptly.**

### **3. EVERY 1,500 HOURS OR ONE YEAR:**

**Change the hydraulic oil once a year; more often under adverse conditions.**

**TO CHANGE THE HYDRAULIC OIL, turn OFF the power to the machine. Remove the drain plug from the bottom of the reservoir. Allow the oil to drain. Replace with 4 U.S. gallons (15 liters) of a lightweight, non-foaming, hydraulic oil such as Mobil DTE 25 or equivalent.**

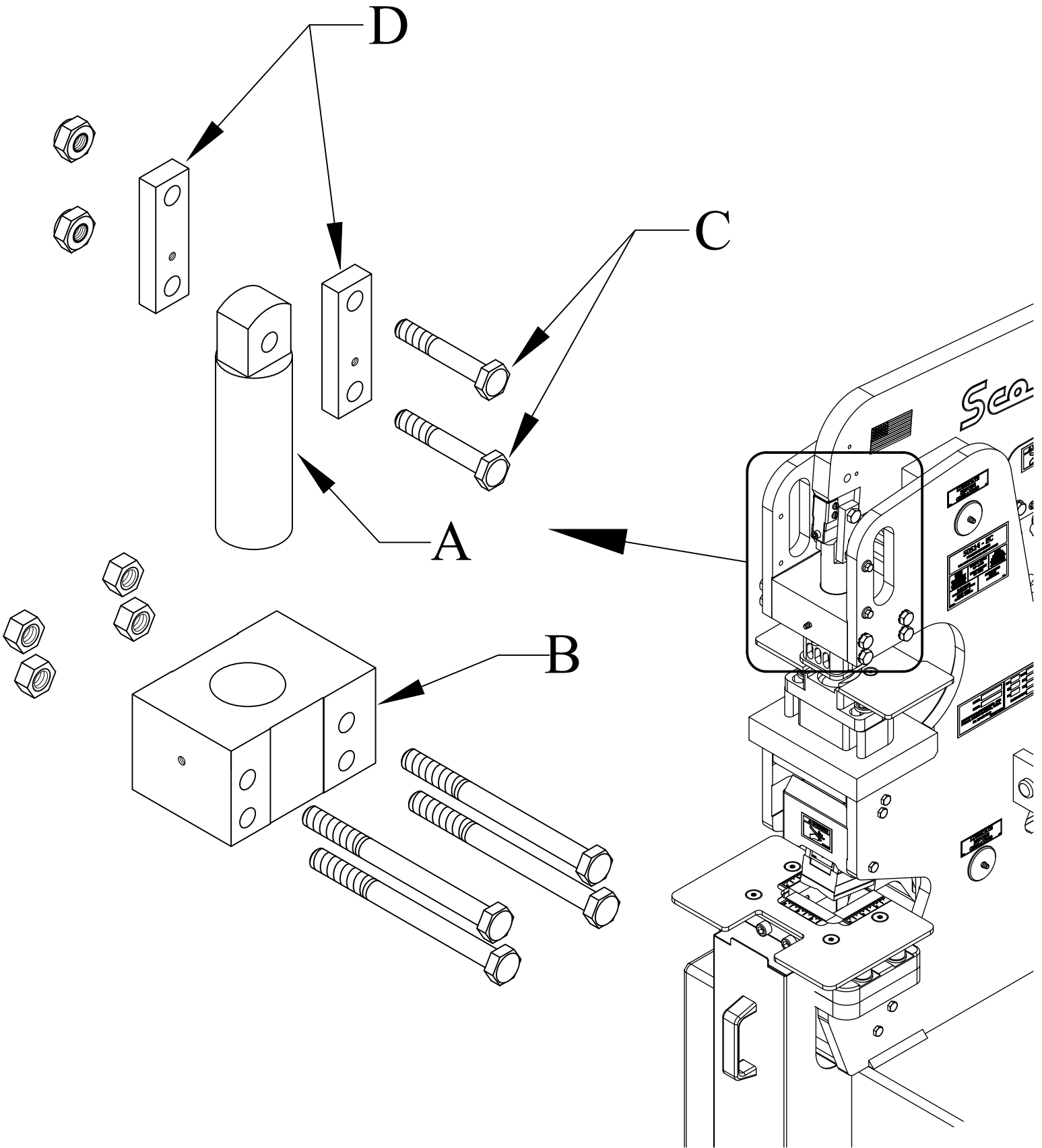

FIGURE 8

# 6.0 MACHINE OPERATION

## 6.1 PUNCH OPERATION

➡ ALWAYS WEAR SAFETY GLASSES.

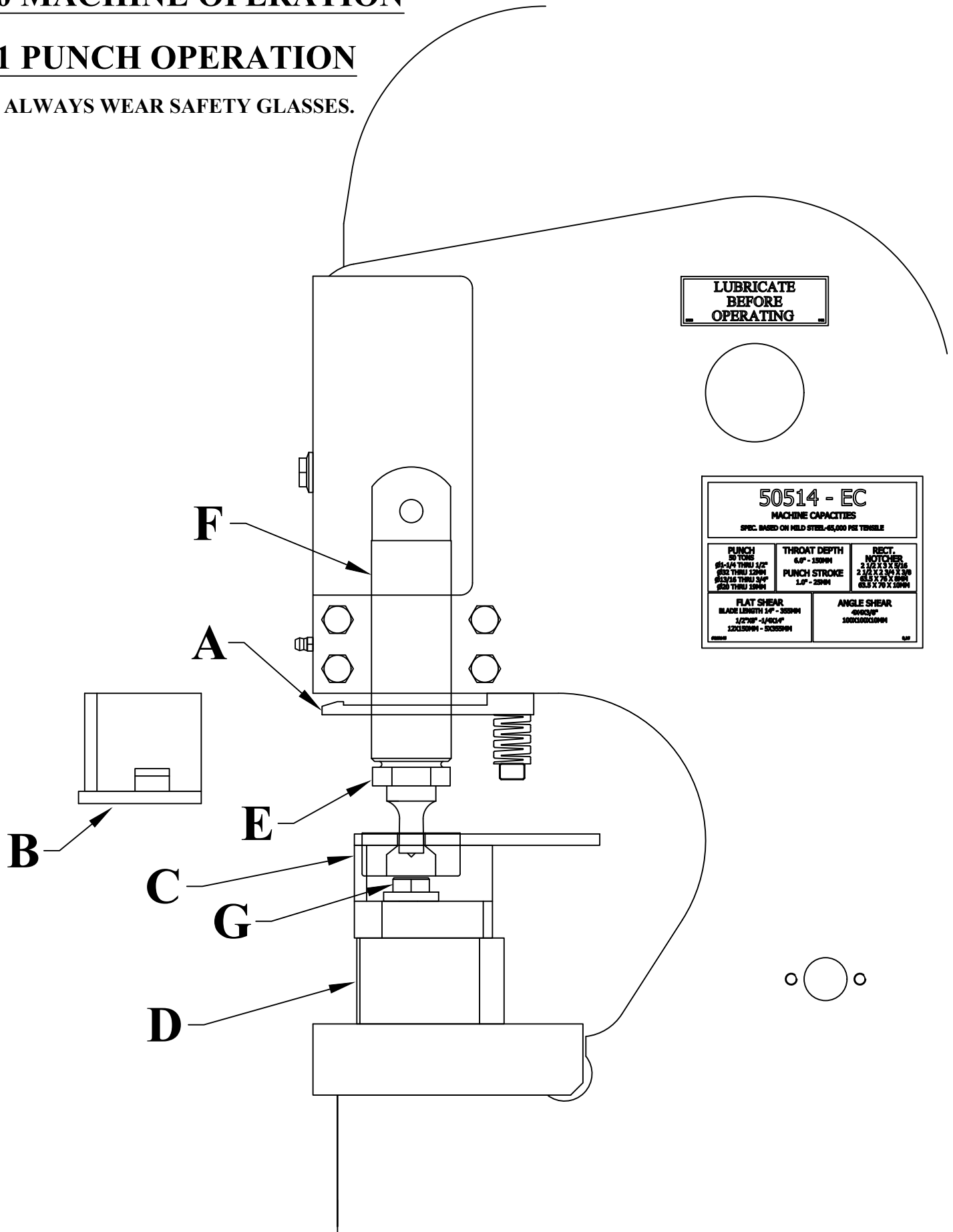

FIGURE 9

**☒ NOTE: THE FIRST AND MOST IMPORTANT PROCEDURE IS THE PROPER METHOD OF INSTALLING AND ALIGNING PUNCHES AND DIES.**

**☞ WARNING: FAILURE TO PROPERLY ALIGN PUNCHES AND DIES CAN CAUSE SERIOUS INJURY TO PERSONNEL AND/OR DAMAGE TO EQUIPMENT. PLEASE READ CAREFULLY AND UNDERSTAND THE FOLLOWING METHOD. IT WILL ALSO BE HELPFUL TO REFER TO THE SAFETY DVD PROVIDED FOR A VISUAL REFERENCE. IF YOU DID NOT RECEIVE A SAFETY DVD, PLEASE CONTACT YOUR DEALER OR THE FACTORY.**

**A. ALIGNMENT AND REMOVAL OF PUNCHES AND DIES.  
REFER TO FIGURE 9 ON THE PRECEDING PAGE.**

- 1. With the machine in the SHEAR position and the arms up, turn the machine's electrical power OFF at the disconnect switch.**
- 2. Remove the stripper (B) by pressing down on the tab (A) and pulling the stripper toward you.**
- 3. Loosen and remove the bolts (G) holding the die holder (C) and remove the die holder (C) and spacer (D)**
- 4. Loosen the set screw holding the die. Remove the die and set it aside.**
- 5. Loosen and remove the punch retaining nut (E) and set the punch retaining nut and punch aside.**
- 6. Select the proper punch and die. Make sure that there is proper clearance between the punch and die.**

**☒ PLEASE NOTE: ALL OF OUR #20K PUNCHES, INCLUDING OVALS, SQUARES, HEXAGONS AND SPECIAL ORDER PUNCHES, ARE SUPPLIED WITH A LOCKING KEY WAY MACHINED INTO THE PUNCH. THIS KEY WAY MATES WITH A KEY BUILT IN TO THE MACHINE'S PUNCH BARREL. ALL PUNCHES USED ON THIS MACHINE MUST BE THE 20K STYLE.**

- 7. Clean both the punch and die.**
- 8. Insert the proper punch in the punch retaining nut (E) and thread it into the punch barrel (F) and tighten it with a wrench. If you are using a shaped punch, rotate the punch by hand until it seats on the key before tightening the nut.**
- 9. Insert the proper die in the die holder with the flat side of the die aligned with the set screw. Tighten the set screw firmly with a hex key wrench.**
- 10. Place the die holder (C) on the bolster and raise it up so that the punch enters the die.**
- 11. Insert the spacer plate (D) between the die holder (C) and the bolster.**
- 12. Align the punch to the die so that there is equal clearance on all sides of the punch in the die.**
- 13. Insert and tighten both the die holder bolts (G) firmly.**
- 14. Check to be sure that the punch and die are still in alignment. Realign, if necessary.**
- 15. Replace the stripper (B).**

☒ **NOTE: If punching holes larger than 1", remove the stripper plate or it will be damaged.**

16. **Check to make sure that there are no objects (such as tools) on or under any of the moving parts of the machine.**
17. **Place the disconnect switch in the ON position and the selector switch (C) in the START position.**
18. **Power the machine by pressing the green START button.**
19. **Place the selector switch in the PUNCH position.**
20. **Lubricate the punch and die before using and every 5 to 10 holes, thereafter.**

**FOR LUBRICATION INSTRUCTIONS, SEE SECTION 5.1.**

☒ **CAUTION: REMOVE THE PUNCH AND DIE WHEN THEY ARE NOT IN USE.**

#### **B. CHECK PUNCHING TOOLS FOR TIGHTNESS.**

Periodically during the day, check the punch and die for alignment. To do this, place the selector arm in the SHEAR position and turn the machine's power OFF. Tighten the set screw holding the die, the die holder bolts and the punch retaining nut. Check the alignment of the punch and die. Power the machine and jog the punch up and down several times, to be sure of proper alignment. Place the selector arm in the PUNCH position.

#### **C. CONTACT BOTH SIDES OF THE STRIPPER.**

Punch holes with sufficient material to contact both sides of the punch stripper. If the workpiece does not contact both sides of the stripper, the side thrust may break the punch and will deform the workpiece.

#### **D. SPECIAL STRIPPERS MAY BE REQUIRED FOR CERTAIN JOBS.**

The standard stripper has been designed to work for most applications. For other applications, such as stripping small channel, a special stripper may have to be fabricated. The important consideration is to keep material level while stripping. When punching thin strap iron, the material will tend to draw up into the stripper. To prevent this, a plate that bolts to the bottom of the stripper, is supplied. This type of stripper will also allow you to punch in the corners of material. There is an oversize stripper available for oversize punching applications.

#### **E. PUNCHING ANGLE IRON.**

This machine is designed to punch angle iron with the leg down. If the application requires punching closer to the web than the standard dies allow, special offset dies are available. **FOR ADDITIONAL INFORMATION ON PUNCHES AND DIES, SEE THE TOOLING MANUAL.**

☒ **CAUTION: PUNCHING ANGLE IRON WITH THE LEG UP WILL CAUSE DAMAGE TO THE PUNCH RETAINING NUT.**

**F. PUNCHING CAPACITIES**

MATERIAL THICKNES		MAXIMUM PUNCH SIZES FOR MILD STEEL (65,000 PSI TENSILE)	DIAMETER OF HOLE	
INCHES	MM		INCHES	MM
1/4	6	OPTIONAL DIE HOLDER	2-1/4	57
5/16	8	OPTIONAL DIE HOLDER	2	50
3/8	10	OPTIONAL DIE HOLDER	1-5/8	41
1/2	12.5	OPTIONAL DIE HOLDER	1-3/16	30
3/4	19	OPTIONAL DIE HOLDER	3/4	19

HOLE DIAMETER		1/8	3/16	1/4	5/16	3/8	7/16	1/2	9/16	5/8	11/16	3/4	13/16	7/8	15/16	1
		.125	.1875	.250	.3125	.375	.4375	.500	.5625	.625	.6875	.750	.8125	.875	.9375	1.00
METAL GAUGE	THICKNESS INCHES	PRESSURE IN TONS														
28	.015	.2	.2	.3	.4	.4	.5	.6	.7	.7	.8	.9	1.0	1.1	1.2	1.3
26	.018	.2	.3	.4	.4	.5	.6	.7	.8	.9	1.0	1.1	1.1	1.2	1.3	1.4
24	.024	.2	.4	.5	.6	.7	.8	.9	1.1	1.2	1.3	1.4	1.5	1.6	1.8	1.9
22	.030	.3	.4	.6	.7	.9	1.0	1.2	1.3	1.5	1.6	1.8	1.9	2.1	2.2	2.4
20	.036	.4	.5	.7	.9	1.1	1.2	1.4	1.6	1.8	1.9	2.1	2.3	2.5	2.6	2.8
18	.048	.5	.7	.9	1.2	1.4	1.6	1.9	2.1	2.4	2.6	2.8	3.1	3.3	3.5	3.8
16	.060	.6	.9	1.2	1.5	1.8	2.1	2.3	2.6	2.9	3.2	3.5	3.8	4.1	4.4	4.7
14	.075	.7	1.1	1.5	1.8	2.2	2.6	2.9	3.3	3.7	4.0	4.4	4.8	5.1	5.5	5.9
12	.105	1.0	1.5	2.1	2.6	3.1	3.6	4.1	4.6	5.1	5.7	6.2	6.7	7.2	7.7	8.2
10	.135	1.3	2.0	2.6	3.3	4.0	4.6	5.3	5.9	6.6	7.3	7.9	8.6	9.2	9.9	10.6
5/32	.157	-	2.3	3.1	3.8	4.6	5.4	6.1	6.9	7.7	8.4	9.2	10.0	10.7	11.5	12.3
3/16	.188	-	2.8	3.7	4.6	5.5	6.4	7.4	8.3	9.2	10.1	11.0	12.0	12.9	13.8	14.8
1/4	.250	-	-	4.9	6.1	7.4	8.6	9.8	11.1	12.3	13.5	14.7	16.0	17.2	18.4	19.7
3/8	.375	-	-	-	-	11.1	12.8	14.8	16.5	18.5	20.2	22.1	23.8	25.8	27.5	29.5
1/2	.500	-	-	-	-	-	-	19.7	22.0	24.6	26.9	29.5	31.8	34.4	36.8	39.4
5/8	.625	-	-	-	-	-	-	-	-	30.8	33.7	36.9	39.9	43.0	46.0	49.2
3/4	.750	-	-	-	-	-	-	-	-	-	-	44.3	47.7	51.7	55.2	59.0
1	1.00	-	-	-	-	-	-	-	-	-	-	-	-	-	-	80.0

**FIGURE 10**

Your Scotchman Ironworker is designed to operate in mild steel. Within conservative limits, it can also operate in medium carbon annealed steels and some forms of abrasion resistant steels. Conditions of high shock can be encountered when punching alloy steels and accordingly, the machine rating must be reduced.

☒ **NOTE: WHEN CONDITIONS OF HIGH SHOCK ARE ENCOUNTERED, SET THE DOWN STROKE OF THE MACHINE SO THAT THE PUNCH STOPS JUST ABOVE THE PLANE OF THE DIE. THIS WILL REDUCE THE SHOCK WHEN THE PUNCH BREAKS THROUGH THE MATERIAL.**

The 50514-EC Ironworker uses # 20K punches and dies that have a built-in clearance of thirty two (.032) thousandths of an inch. Under normal punching conditions, a punch will use a corresponding die stamped the same size. A 3/8 inch punch will use a die stamped 3/8 inch. All Scotchman punches and dies are stamped with the size.

All dies have a larger hole in the bottom side for slug relief. Make sure that the smaller side of the die mates to the punch before installing it in the machine.

When punching materials other than mild steel or in cases of high punch shock, we recommend increasing the CLEARANCE. In thin materials, the recommended clearance is 1/10 of the material thickness. We do not recommend clearances of less than 1/64 of an inch, due to working clearances in the machine.

**G. DO NOT PUNCH MATERIAL THICKER THAN THE DIAMETER OF THE PUNCH.**

This "RULE OF THUMB" can be extended, but the punch supplier or Scotchman should be consulted first, (i.e. do not punch material thicker than 1/4 inch with a 1/4 inch diameter punch). This rule of thumb applies to mild steel only and must be reduced by 50 percent when punching alloy steels.

☒ **CAUTION: CONTACT YOUR LOCAL DEALER OR THE FACTORY BEFORE ATTEMPTING TO PUNCH ANY TYPE OF ALLOY STEEL.**

**H. PUNCH FULL, COMPLETE HOLES.**

The side thrust encountered in punching partial holes can force the punch over against the die and result in punch or die breakage. **THIS MAY RESULT IN SERIOUS BODILY INJURY.**

Special nibbling punch and die sets are available for punching into the edge of material. For further information, Contact your local dealer or Scotchman.

**I. MAINTAIN SUFFICIENT MATERIAL BETWEEN THE PUNCHED HOLE AND THE EDGE OF THE WORKPIECE.**

The edge of the punch should clear the edge of the workpiece by a distance equal to the thickness of the material. Any edge distance less than this will result in a deformed workpiece.

**J. DO NOT WORK WITH DULL OR DAMAGED TOOLING.**

**⊗ CAUTION: WORKING WITH DULL OR DAMAGED PUNCHES AND DIES WILL INCREASE THE TONNAGE REQUIRED TO PERFORM THE OPERATION. THIS MAY RESULT IN FAILURE OF THE TOOL AND POSSIBLE INJURY TO PERSONNEL. IT WILL ALSO RESULT IN A LESS THAN DESIRABLE WORKPIECE.**



## 6.2 ANGLE SHEAR

The 4 x 4 angle shear is a component tool designed to shear angle iron. It installs on the tool table and has a maximum capacity of 4 x 4 x 3/8 inch (102 x 102 x 10mm) mild steel angle iron. The selector arm must be in the SHEAR position to operate this tool.

### 6.2A ANGLE SHEAR INSTALLATION

SEE FIGURE 11 BELOW.

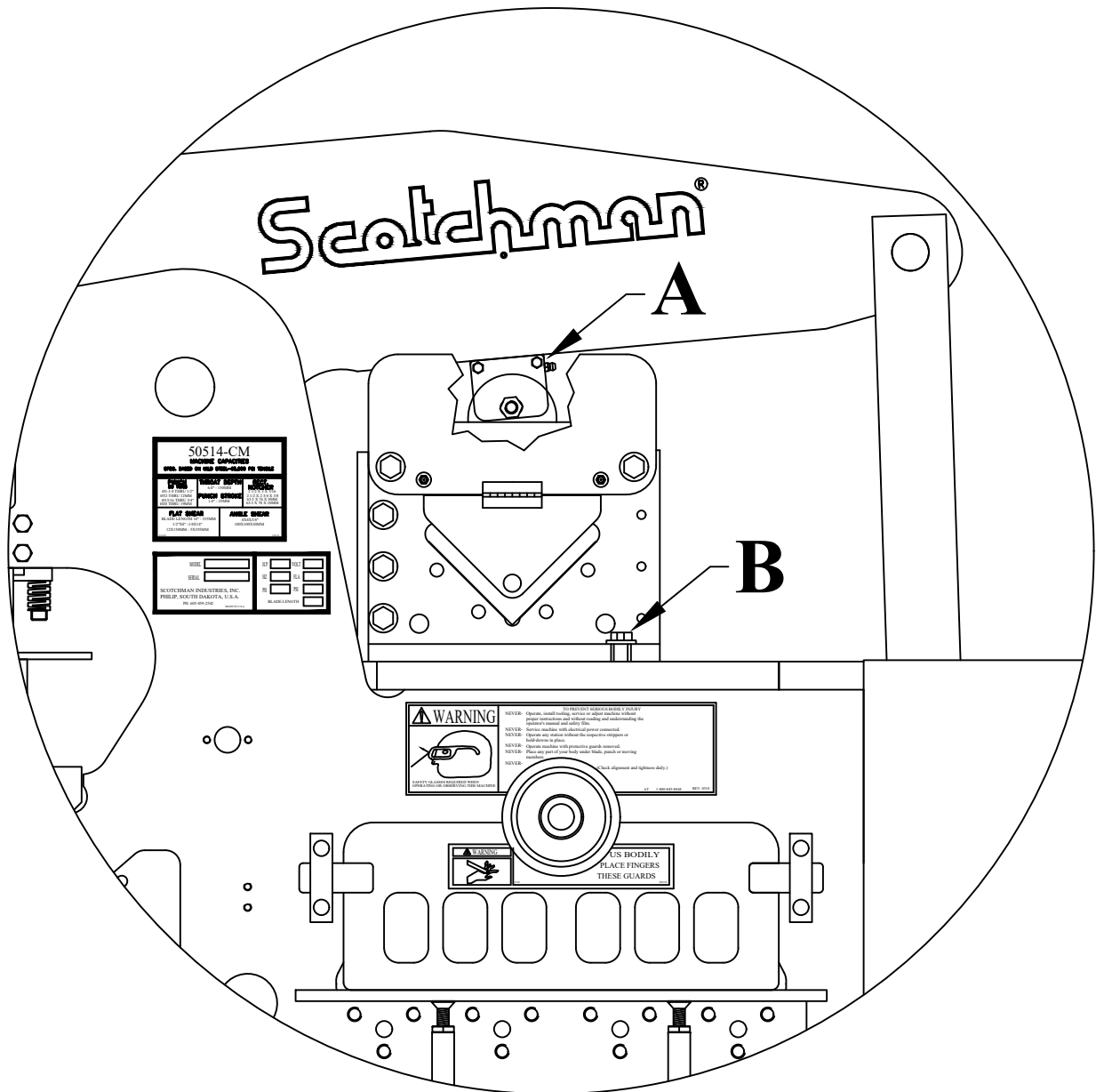

FIGURE 11

The 4 x 4 angle shear mounts on the tool table under the arm.

1. The selector arm must be in the SHEAR position and the arms up.
2. Slide the tool under the arm, as shown.
3. The tool anchors to the tool table with the bolts (B) provided.
4. Make sure that the pressure block (A) is aligned squarely under the arm.
5. Grease the pressure block and blade guides before using and twice daily when this tool is in use.

## **6.2B ANGLE SHEAR OPERATION**

Apply oil to the upper and lower blades before the first cut is made and every 10 to 15 cuts, thereafter. This reduces cutting tonnage and increases blade life.

The selector arm must be in the SHEAR position to operate this tool.

**USE THE FOLLOWING STEPS:**

1. The down-stroke of the machine should be set for the size of the material being sheared.
2. Feed the workpiece through the tool, keeping it horizontal with the tool.
3. Depress the foot pedal and shear the material.

In addition to these basic steps, the operator should be familiar with the following:

### **A. MAINTAIN PROPER BLADE CLEARANCE.**

Do not work with dull or damaged blades. If the blades are chipped or dull, they should be replaced.

**FOR BLADE REPLACEMENT INSTRUCTIONS, SEE SECTION 6.2C.**

A clearance of forty thousandths (.040) of an inch (1mm) per side between the upper and lower blades is recommended for most applications. The clearance is maintained by adding or removing shims between the lower blades and the side plates. When shearing light angle iron, the clearance can be reduced further by adding shim stock.

### **B. MITER CUTTING.**

The angle shear on this model is capable of mitering angle up to 2 x 2 x 1/4 inch (51 x 51 x 6mm) to forty five (45) degrees. To miter cut, raise the guard and line the workpiece up to the scribe marks on the cutting guides. Feed the material into the shear until it contacts the lower blades opposite the side it is being fed from.

### **C. UNEQUAL LEG ANGLE IRON REQUIRES SPECIAL BLADES.**

If large quantities of angle iron having unequal leg length (e.g. 2 x 3 inch or 51 x 76mm) are to be sheared, a special top blade is required. Failure to use a special blade will result in damage to the tool. An occasional piece of unequal leg angle iron may be sheared with no harm to the tool.

**NOTE: If tool ever jams or gets stuck - REMOVE THE TOOL FROM THE MACHINE BEFORE ATTEMPTING TO FREE IT.**

## 6.2C REPLACING OR ADJUSTING ANGLE SHEAR BLADES

SEE FIGURE 12 BELOW.

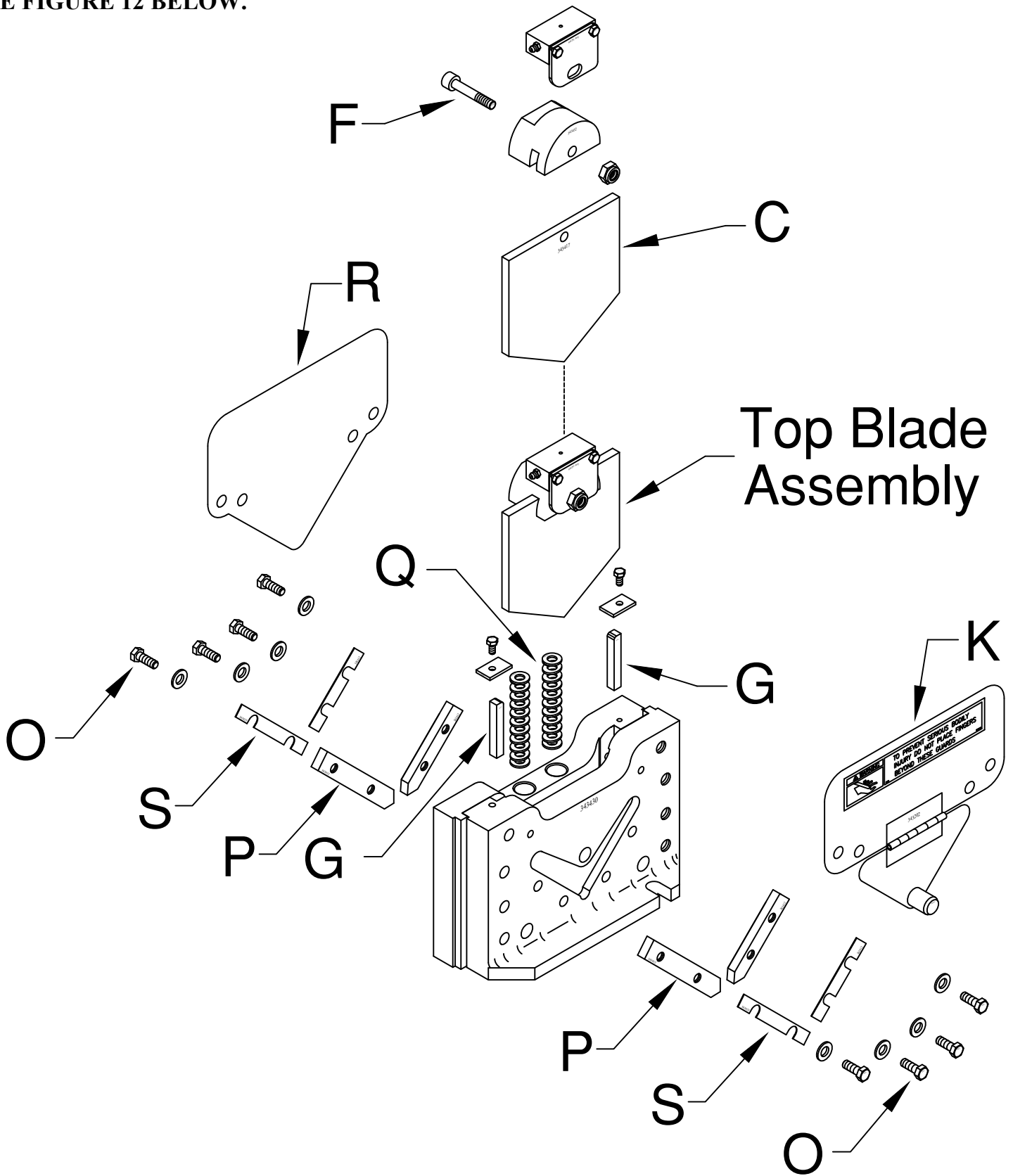

FIGURE 12

- 1. Remove the tool from the machine. Make sure that the selector switch is in the SHEAR position and the punch beam is up before removing the tool.**
- 2. Remove the top blade assembly and the front and back guards (K & R).**
- 3. Remove the bolts (O) from the lower blades and remove the shims (S) and the lower blades (P). The lower blades are symmetrical and can be rotated or moved from side to side, to expose four cutting edges.**
- 4. Rotate or replace the lower blades and shims.**
- 5. Remove the bolt (F) from the top blade and replace the blade (C).**
- 6. Install the top blade assembly in the housing, without the springs (Q) in place, and check the clearance between the upper and lower blades. The clearance should be forty (.040) to forty-five (.045) thousandths per side. If you are shearing light material and the tool is leaving a burr, install the shims provided with the tool.**
- 7. Remove the top blade assembly and install the springs (Q) in the unit. Before installing the top blade assembly, make sure that the guides (G) are in place and in good condition. Lubricate the sides of the top blade and install it in the unit.**
- 8. Oil the blades and grease the tool before performing any work with this tool.**

## **6.3 BAR SHEAR OPERATION**

⊗ **CAUTION: ANY TIME THAT THE SHEAR SECTION IS NOT IN USE, CRANK THE HOLD-DOWN DEVICE TO ITS FULLY CLOSED POSITION. BEFORE USING THE BAR SHEAR, REMOVE THE PUNCH AND DIE FROM THE PUNCH STATION.**

- ➡ **WHEN USING THE BAR SHEAR, ALWAYS USE THE HOLD-DOWN DEVICE.**
- ➡ **NEVER PUT ANY PART OF YOUR BODY BETWEEN THE HOLD-DOWN AND THE MATERIAL TO BE SHEARED.**

A clearance of 1/16 of an inch (1.5mm) between the hold-down and the material is acceptable. The maximum tonnage available is to the left, closest to the pivot point. For applications that do not require the maximum tonnage, move the material to the right, for minimal distortion on the drop-off piece.

Do not attempt to shear pieces that are too short for the hold-down to grip. This will cause the material to kick up and will result in a poor quality cut and possible damage to the machine.

**THE OPERATION OF THE BAR SHEAR CONSISTS OF THE FOLLOWING BASIC STEPS:**

1. **Apply oil to the blades before making the first cut and every 10 to 15 cuts, thereafter. This will reduce cutting tonnage and increase blade life.**
2. **The selector switch must be in the SHEAR position.**
3. **Place the material under the hold-down between the shear blades.**
4. **Crank the hold-down device down to the material. This prevents kick up of the material, which could cause injury to the operator and damage to the machine.**
5. **Keep your hands clear of all moving parts.**
6. **Depress the foot pedal and make the shear stroke.**

**IN ADDITION TO THE ABOVE BASIC STEPS, THE OPERATOR SHOULD BE FAMILIAR WITH THE FOLLOWING:**

### **A. MAINTAIN PROPER BLADE CLEARANCE.**

The quality of the cut is an immediate indication of the condition of the shear blades, the clearance between the blades or the amount of spring back in the shear arm. The blades are symmetrical and can be rotated to expose four (4) cutting edges.

**B. HARD MATERIALS MAY DAMAGE BLADES.**

The 50514-EC Ironworker is designed to shear mild steel rated at 65,000 tensile.

Within conservative limits, it can also operate in medium carbon annealed steel, stainless steel and some forms of abrasion resistant steel.

These materials shear harder and will reduce shearing capacities.

Materials, such as hardened tool steel, will damage or break blades and should not be sheared.

Small, concrete reinforcement bar can be sheared, but will reduce blade life considerably.

**C. KEEP THE CUT-OFF AREA CLEAR.**

Short cuts and slivers tend to build up in the drop off side of the bar shear. Remove these pieces before a build-up develops.

<b><u>MAXIMUM SHEARING CAPACITY IN MILD STEEL:</u></b>			
<b>THICKNESS OF STEEL</b>		<b>WIDTH OF CUT</b>	
<b>INCHES</b>	<b>MM</b>	<b>INCHES</b>	<b>MM</b>
<b>3/4</b>	<b>19</b>	<b>4</b>	<b>102</b>
<b>1/2</b>	<b>12.5</b>	<b>8</b>	<b>203</b>
<b>3/8</b>	<b>10</b>	<b>10</b>	<b>254</b>
<b>1/4</b>	<b>6</b>	<b>14</b>	<b>356</b>
<b><u>OPTIONAL SABER BLADE</u></b>			
<b>1/2</b>	<b>12.5</b>	<b>10</b>	<b>254</b>
<b>3/8</b>	<b>10</b>	<b>12</b>	<b>305</b>

## 6.3A BAR SHEAR ARM ADJUSTMENT

The shear arm adjustment is maintained by a pressure plate at the pivot point and rub blocks on the frame and arm. SEE FIGURE 13 BELOW.

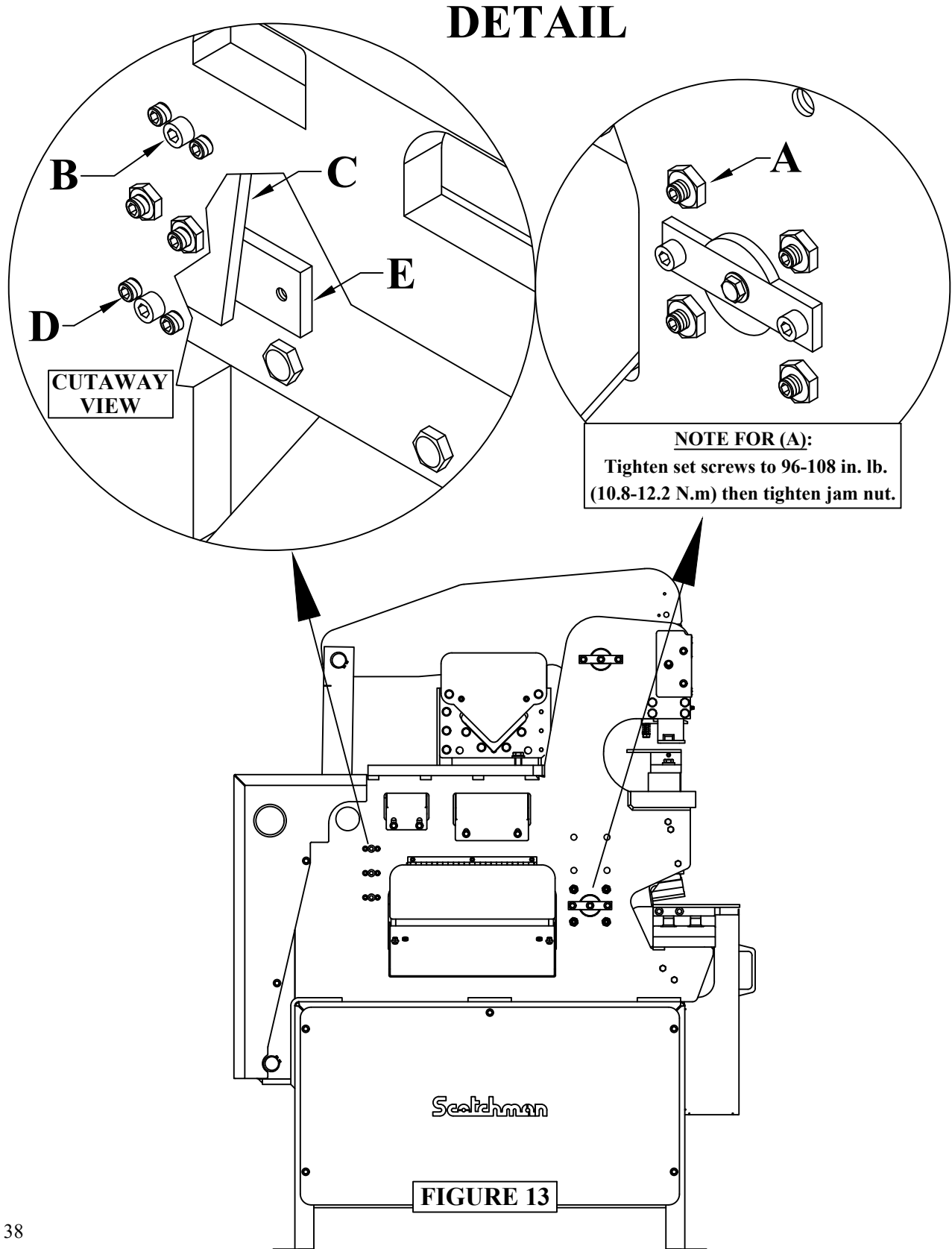

**USE THE FOLLOWING STEPS TO ADJUST THE SHEAR ARM.**

- 1. To prevent damage to the blades, back off or remove the lower shear blade before adjusting the shear arm. After the shear arm adjustments are completed, reset the blades following the instructions in SECTION 6.3B.**
- 2. Loosen the lock nuts on the set screws (A) at the pivot point. Tighten the set screws in a diagonal order to 96-108 in. lb. (10.8-12.2 N.m), then tighten jam nuts. Do not over-tighten the set screws; it will only cause excessive wear.**
- 3. Loosen the mounting bolts (B) from the frame rub block (C) and back off the set screws (D).**
- 4. Inspect the frame rub plate (C) and the shear arm rub plate (E) for wear. Both plates can be rotated, if wear is noted.**
- 5. With the arm in the up position, adjust the top two set screws (D) in until the rub plates (C & E) contact each other.**
- 6. Power the machine and jog the shear arm down until the arm rub plate (E) aligns with the center set screws (D). Adjust the set screws in until the rub plates contact each other. Repeat this step for the bottom set screws.**
- 7. Tighten the rub plate mounting bolts (B) and cycle the machine, making sure that the rub plates make contact throughout the full cycle.**



## **6.3B BAR SHEAR BLADE ADJUSTMENT PROCEDURE**

SEE FIGURE 14 ON THE FOLLOWING PAGE.

1. Place the selector switch in the SHEAR position and allow the arms to raise completely.
2. Remove the hold-down device (A) and the shear table (B).
3. To remove the shear table, loosen the jam nut (F) on the bolts (C) and remove the bolt. Remove the lower blade bolts (E) and back the adjustment screws (D) out.
4. Remove the lower blade.
5. Power the machine and place the selector switch in the PUNCH position. Allow the arm to travel to its full down position. Turn the power off.
6. Rotate or replace the shear blade on the arm.
7. Rotate or replace the lower blade and start the socket head retaining bolts (E).
8. Place a shim with the desired clearance between the upper and lower blades.
9. Adjust the lower blade to the top blade, with the upper adjusting screws (D), about 1/8 of a turn past resistance.
10. Tighten the bolts (E) 1/8 to 1/4 a turn past resistance.
11. Adjust the lower adjusting screws (D) up to the blade and then tighten all of the bolts, starting with the blade bolts (E) and then, the adjusting screws (D).
12. ☒ CAUTION: THE BLADES MUST BE ADJUSTED PARALLEL TO EACH OTHER, vertically or with the cutting edge of the lower blade at a slight cant towards the upper blade.
13. Power the machine and place the selector switch in the SHEAR position. With the foot pedal, cycle the shear down slowly, watching the blade engagement. Make sure that the blades do not contact each other.
14. Replace the shear table (B) and the hold-down device (A). If needed, the shear table can be adjusted to match the lower blade.
15. The table is adjusted with the four screws (G). If the machine is being used to shear maximum capacities, we recommend increasing the clearance. A clearance of five to seven percent of the material thickness is recommended.

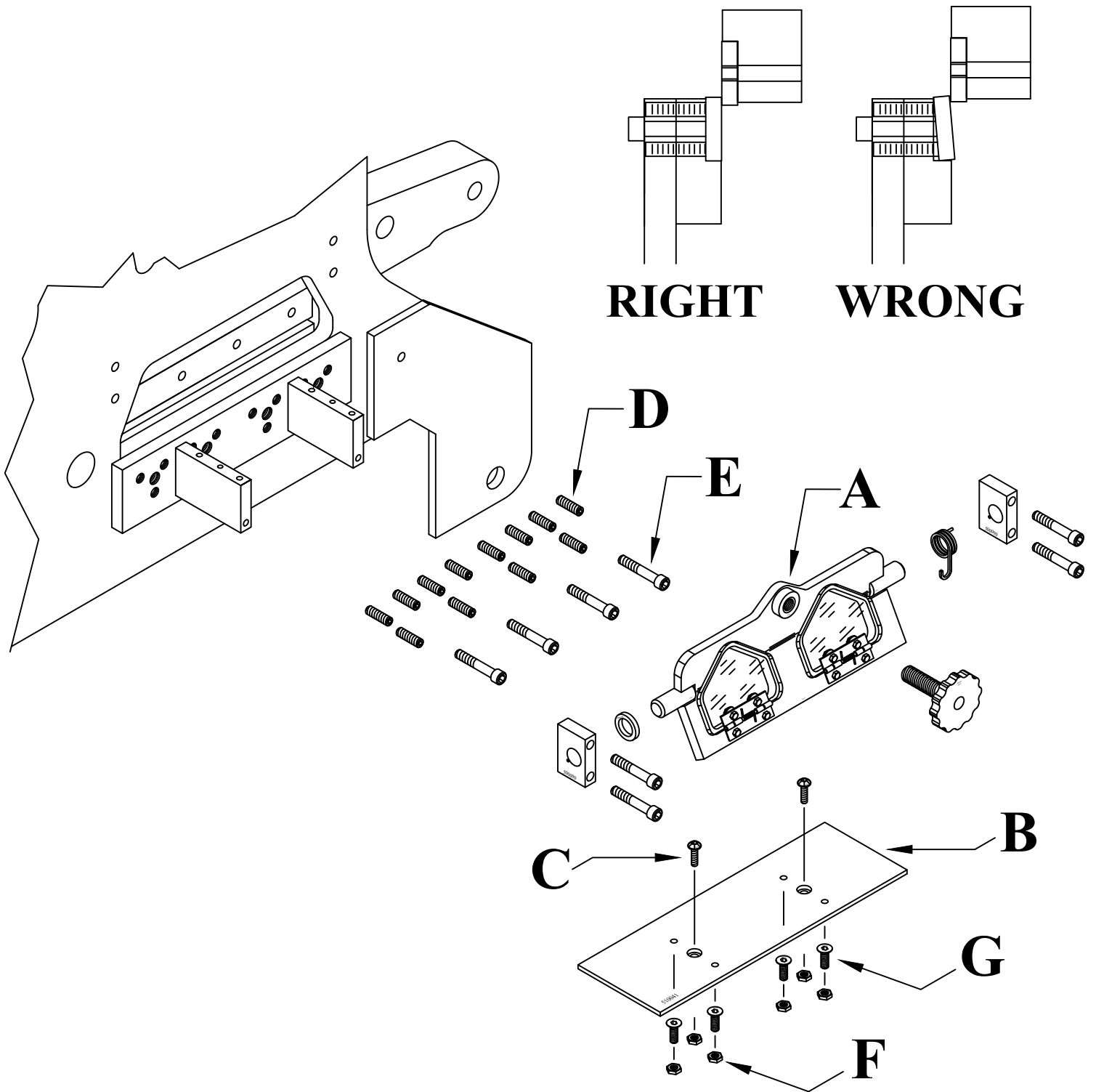

**FIGURE 14**

## 6.4 RECTANGLE NOTCHER OPERATION

This tool is operated with the selector switch in the PUNCH position.

- ⊗ **CAUTION: WHEN THE NOTCHER STATION IS NOT IN USE, BE SURE THAT THE GUARD IS IN THE FURTHERMOST DOWN POSITION, TO PREVENT ANYONE FROM STORING TOOLS OR MATERIAL ON THE TABLE OR IN THE BLADE CAVITY.**

Notching applications up to 2-1/2 x 3 x 5/16 inch (63 x 76 x 8mm) rectangular and 2-1/2 x 2 1/2 inch (63 x 63mm) 90 degree vee notch in 5/16 inch (8mm) material is the maximum capacity of this section of the machine.

**TO OPERATE THE NOTCHER, USE THE FOLLOWING STEPS:**

1. Open the guard.
2. Place the workpiece between the blades. Cycle the machine until the blades have sheared through the material. Continue to hold your foot on the pedal while you remove the material toward you on a horizontal plane.
3. Once the material is away from the blades, remove your foot from the pedal. The machine will return to a neutral position, ready for the next cut.

### 6.4A NOTCHER BLADE ADJUSTMENT OR REPLACEMENT

SEE FIGURE 15 ON THE FOLLOWING PAGE.

1. Place the machine in the PUNCH position and allow the machine to retract to the end of the stroke. **TURN THE MACHINE OFF!!**
2. Remove the notcher table (D).
3. Remove the bolts (F) holding the lower blade holder (C) and remove it.
4. The lower blades (B) can now be replaced or rotated, to expose a new cutting edge.
5. Remove the top blade (A). The top blade cannot be rotated and must be replaced, if damaged. Before installing a new top blade, check the arm for possible wear. If there is no wear, install the new blade on the arm.
6. Power the machine.
7. Place the selector switch in the SHEAR position and allow the machine to travel to this position.
8. Replace the lower blade holder (C) with the blades (B) installed. Start the mounting bolts (F). **DO NOT TIGHTEN.**
9. Manually align the lower blades to the upper blades, with equal clearance all the way around. A clearance of twenty five thousandths (.025) of an inch (.6mm) is recommended. The lower blades may require shimming to achieve the proper clearance. Tighten the blade holder bolts to approximately 100 foot pounds of torque (136 N•m). Recheck the alignment.
10. Install the notcher table (D).

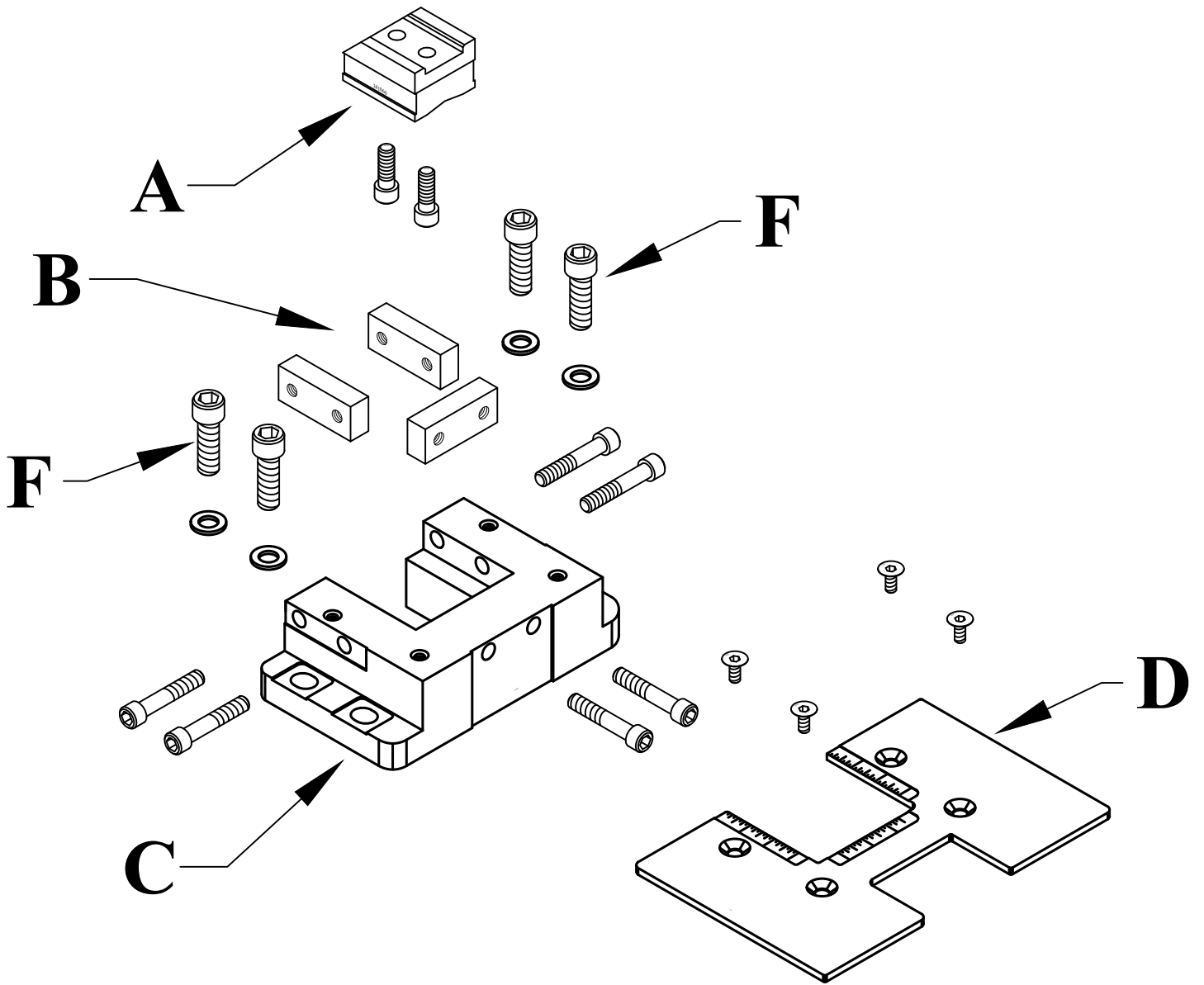

FIGURE 15

## **6.5 OPTIONAL JOG CONTROL**

SEE FIGURE 16 ON THE FOLLOWING PAGE.

On the 50514-EC Ironworker, a jog control is available as optional equipment.

This option is available as either a factory install option or a field retrofit kit.

To utilize this feature, place the RUN/JOG (A) switch in the JOG position.

When the switch is in the RUN position, the jog control is inoperable and the machine is controlled by the foot pedal.

When the switch is in the JOG position, the foot pedal is inoperable. The machine is then controlled by the JOG button (B) and is controlled up or down by the respective arrows on the jog button. The arrows will correspond with the correct direction of travel, whether the machine is used in the SHEAR or the PUNCH operation. This feature is very helpful for setting the stroke controls precisely, to eliminate excessive travel to the workpiece and for setting up the optional tooling that is available for the punch station and the tool table. The jog control is also useful for many of the maintenance and repair functions discussed in this manual.

**⊗ CAUTION: WHEN THE JOG FEATURE IS USED, THE MACHINE WILL REMAIN AT WHATEVER POINT THE JOG CONTROL IS RELEASED. WHEN THE RUN/JOG SWITCH IS CHANGED TO THE "RUN" POSITION, THE MACHINE WILL MOVE TO WHATEVER POSITION THE SELECTOR SWITCH IS SET IN.**

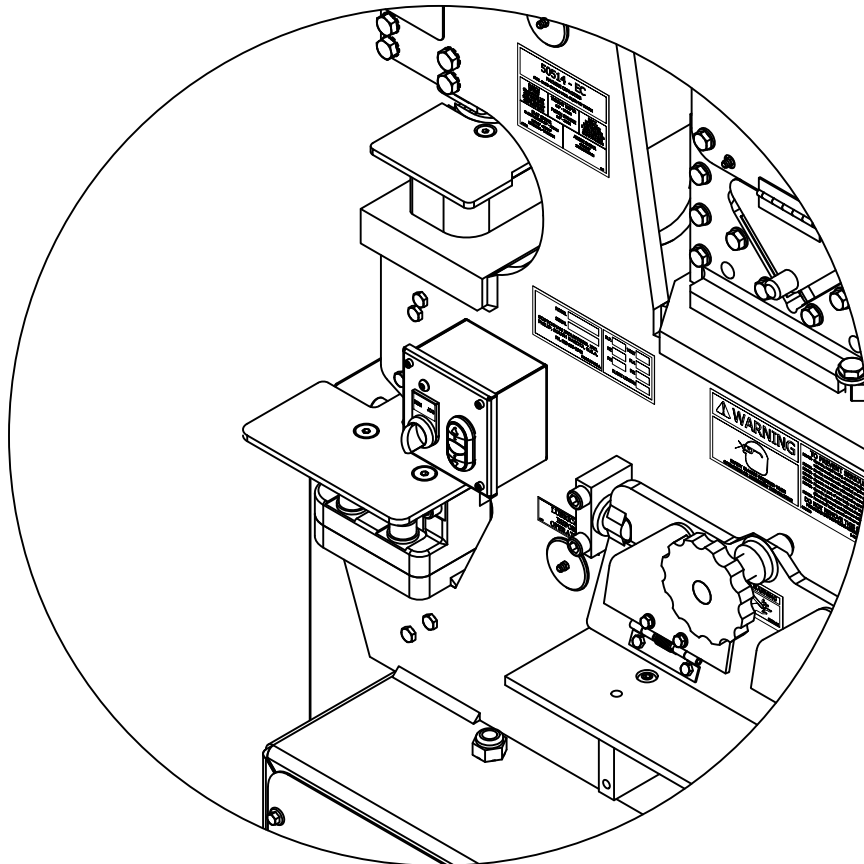
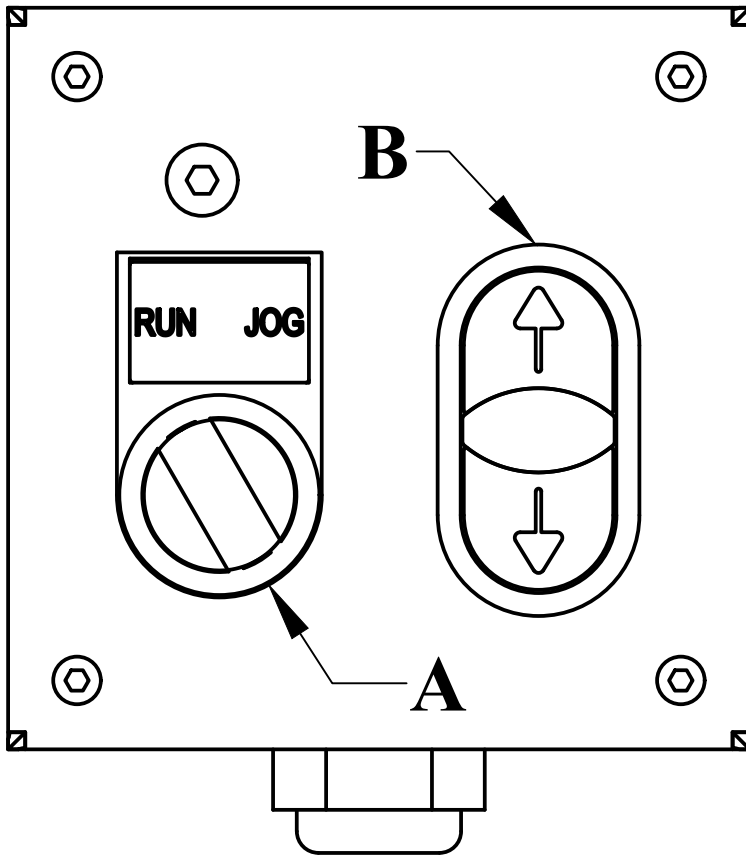

FIGURE 16

## 7.0 OPTIONAL TOOLS

- ⊗ **CAUTION:** WHEN USING THE TOOL STATION, CRANK THE HOLD-DOWN DEVICE ON THE BAR SHEAR CLOSED AND ROTATE THE PUNCH AND DIE OUT FROM THE PUNCH STATION.
- ➡ AS WITH ALL FUNCTIONS ON THIS MACHINE, SAFETY GLASSES ARE REQUIRED WHEN USING OPTIONAL TOOLS OF ANY TYPE.

Each self contained tool has its own stroke and tonnage requirements.

This section will cover the installation, operation and maintenance of each tool.

### 7.1 ROD SHEAR

The rod shear is a component tool designed to shear solid sections of round and square stock.

It has a maximum capacity of 1 inch (25mm) in round or in 3/4" (19mm) square.

The selector switch must be in the SHEAR position to operate this tool.

#### 7.1A ROD SHEAR INSTALLATION

SEE FIGURE 17 ON THE FOLLOWING PAGE.

The rod shear mounts on the tool table in place of the angle shear and is anchored with the bolts provided. Mount the tool so that it is aligned squarely under the arm and lubricate the pressure cap on the top of the tool before installing it.

The rod shear requires a short stroke (approximately 1/2 inch, 12mm) and takes no slug. The stroke of the machine must be set when using this tool.

Set the up-stroke so that the material will feed freely through the unit. Set the down stroke just low enough to make the cut.

#### 7.1B ROD SHEAR OPERATION

Oil should be applied to both blades before the first cut and after every 10 to 15 cuts. Grease the pressure block between the arm and the tool every two hours of operation. On all round sizes, select the cavity closest to the size being sheared. In the square cavity, there is a kick up bolt adjustment.

Adjust this bolt so that the workpiece will just feed under the bolt and remains horizontal to the tool.

**NOTE:** If tool ever jams or gets stuck - REMOVE THE TOOL FROM THE MACHINE BEFORE ATTEMPTING TO FREE IT.

- ⊗ **CAUTION:** ALWAYS REMOVE THE ROD SHEAR WHEN IT IS NOT IN USE.

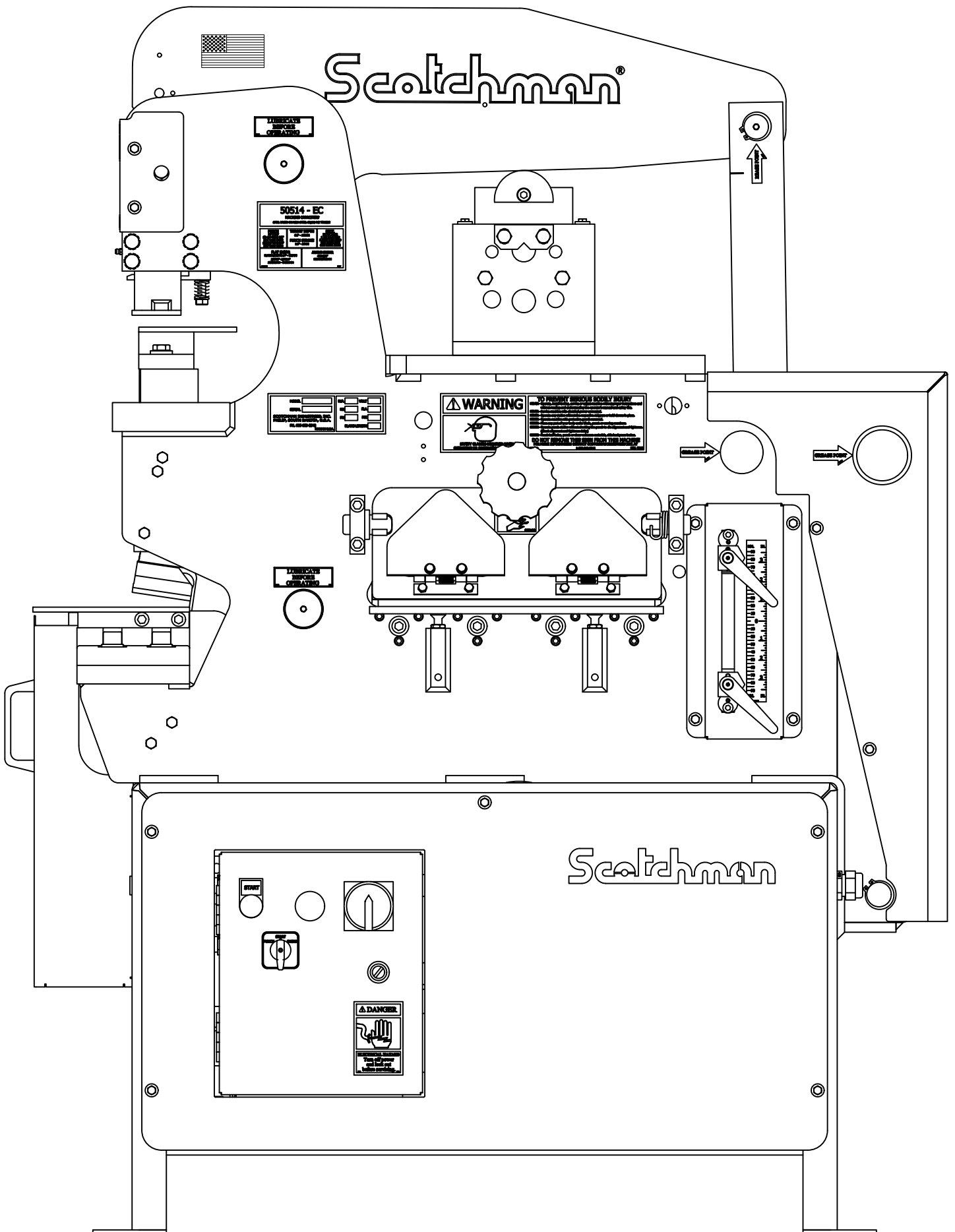

FIGURE 17



## 7.2 SIX INCH BRAKE

The six inch brake is a component tool designed to bend and form mild steel.

The six inch brake mounts in the punch station.

The selector switch must be in the PUNCH position to operate this tool.

### 7.2A SIX INCH INSTALLATION

SEE FIGURE 18 ON THE FOLLOWING PAGE.

1. Remove the die holder, stripper and punch retaining nut from the punch station you are going to use.  
  
▶ **NOTE: TO USE THIS TOOL, THE STRIPPER MOUNTING PLATE (D) MUST ALSO BE REMOVED. FAILURE TO REMOVE THE STRIPPER MOUNTING PLATE WILL CAUSE DAMAGE TO THE BRAKE.**
2. Install the upper brake die (A) in the punch barrel. Do not tighten the retaining nut at this time.
3. Bolt the brake base (B) to the punch bolster, using the two bolts from the die holder. Do not tighten at this time.
4. Place the lower brake die (C) in the brake base (B).
5. Align the upper and lower dies and tighten the punch retaining nut and bolts in the base.

### 7.2B SIX INCH OPERATION

The brake must be center loaded, to prevent damage to the tool.

If a bend of less than ninety degrees is required, set the stroke control adjustment until the desired bend is achieved.

The lower die can be rotated to expose four different vee opening sizes (1/2, 5/8, 7/8 and 1 inch).

The maximum material capacity for this tool is 1/4 x 6 inch (6 x 152mm).

<p><b>NOTE: If tool ever jams or gets stuck - REMOVE THE TOOL FROM THE MACHINE <u>BEFORE</u> ATTEMPTING TO FREE IT.</b></p>
---

⊗ **CAUTION: ALWAYS REMOVE THIS TOOL WHEN IT IS NOT IN USE.**

# REMOVE

**(D)**  
**3 pcs.**

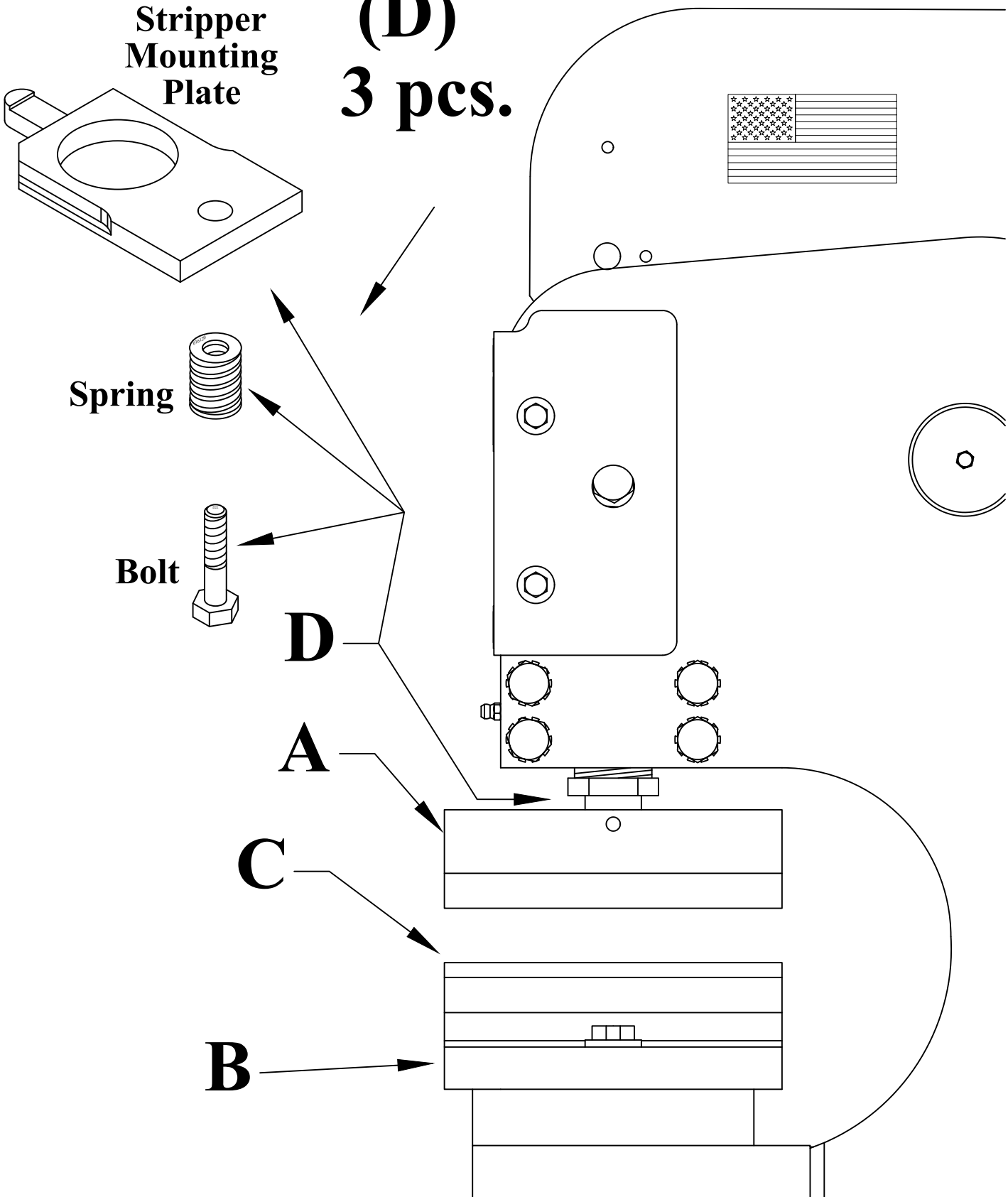

FIGURE 18

## 7.3 EIGHT & TWELVE INCH BRAKE

The eight and twelve inch brakes are component tools designed to bend and form mild steel. They mount on the tool table in place of the angle shear. The brakes are shipped with standard dies to accommodate material up to 1/4 inch (6mm) thick. The selector switch must be in the SHEAR position to operate these tools.

### 7.3A EIGHT & TWELVE BRAKE INSTALLATION

SEE FIGURE 19 ON THE FOLLOWING PAGE.

Before installing the brake, lubricate the pressure block on both sides. Make sure that there is lubrication between the pressure block and the arm and between the block and the brake. Lubricate the pressure block every two hours of operation. The eight and twelve inch brakes mount on the tool table in place of the angle shear and are anchored with the bolts provided. The brake base is provided with four mounting holes; only two are required to mount the tool on this machine. Mount the brake as close to the machine's frame as possible. THERE IS A PRESS BRAKE TONNAGE CHART ON THE FOLLOWING PAGE, FIGURE 20, THAT WILL BE HELPFUL WHEN USING A BRAKE ON THIS MACHINE. On this model, the eight inch brake has twenty four tons of force and the twelve inch brake has twenty tons.

### 7.3B EIGHT & TWELVE INCH BRAKE OPERATION

⊗ **CAUTION: NEVER PUT YOUR HANDS INTO OR AROUND A BRAKE WHILE IT IS IN OPERATION.**

Hold short pieces with tongs or similar devices. In using the brake, it is necessary to load the brake centrally. (Visual centering is sufficient.) If work is performed off-center, the guide pins could be damaged. The brake lift is provided by springs. If sticking occurs at the bottom of the stroke and the upper die does not return, usually a slight tap on the upper die is sufficient to free the guides.

⊗ **CAUTION: NEVER ATTEMPT TO FREE THE BRAKE BY HAND.**

Sticking can be caused by lack of lubrication, the complexity of the part being bent or bent guide pins. Keep the guides well lubricated. It is common practice to have the bottom die opening 8 times the thickness of the material being bent.

FOR TONNAGE REQUIREMENTS, SEE FIGURE 20 ON THE FOLLOWING PAGE.

If parts require bends of less than 90 degrees, adjust the stroke until the desired bend is obtained. A great variety of standard brake dies can be used with this unit. These are available from Scotchman Industries or your local dealer.

**NOTE: If tool ever jams or gets stuck - REMOVE THE TOOL FROM THE MACHINE BEFORE ATTEMPTING TO FREE IT.**

⊗ **CAUTION: ALWAYS REMOVE THIS TOOL WHEN IT IS NOT IN USE.**

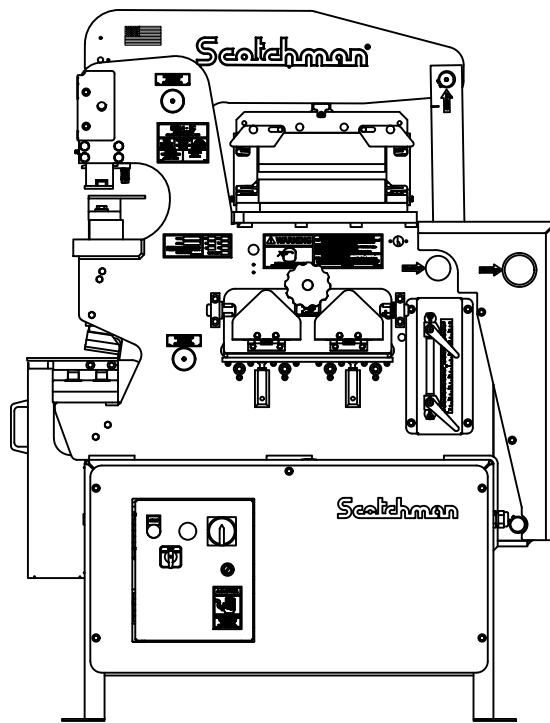

FIGURE 19

## TONNAGE CHARTS

PRESSURE IN TONS PER LINEAR FOOT REQUIRED TO MAKE 90 DEGREE AIR BEND IN MILD STEEL

THICKNESS OF METAL		WIDTH OF V-DIE OPENING																					
		1/4	5/16	3/8	1/2	5/8	3/4	7/8	1	1-1/8	1-1/4	1-1/2	2	2-1/2	3	3-1/2	4	5	6	7	8	10	12
GAUGE	INCHES																						
20	.036	2.9	2.2	1.7	1.2	1.0																	
18	.048		4.0	2.9	2.2	1.6	1.3																
16	.060			5.6	3.6	2.7	2.2	1.7															
14	.075				6.0	4.5	3.4	3.0	2.5	2.1													
13	.090					6.8	5.4	4.3	3.7	3.3	2.9												
12	.105					10.1	7.4	6.3	5.4	4.4	4.0	3.2											
11	.120						10.5	8.8	7.2	6.2	5.4	4.3	3.2										
10	.135							9.6	8.4	7.0	6.2	5.4	4.1										
9	.150							11.3	9.6	8.4	7.0	6.2	5.4	4.1									
7	.188								13.1	11.9	9.0	6.7	5.2	3.5									
1/4	.250									16.4	14.0	11.2	7.6	5.8	4.5								
5/16	.313										28.8	22.0	15.3	11.5	9.1	7.5	6.2						
3/8	.375											38.0	26.0	19.2	16.0	12.5	10.6	7.6					
7/16	.438												41.0	29.9	24.0	19.4	16.0	12.3	9.3				
1/2	.500													45.2	35.0	28.0	24.0	17.0	14.6	11.1			
5/8	.625														47.9	39.0	33.1	24.0	19.0	15.6	12.7		
3/4	.750															69.5	58.0	42.2	32.4	26.0	23.0	16.5	
7/8	.875																92.0	69.0	52.2	42.2	36.0	27.0	21.0
1.0	1.00																	104.0	80.0	63.0	52.5	39.4	31.2
																			112.2	90.0	76.0	56.2	44.0

PRESSURES HIGHLIGHTED ARE FOR DIES WITH FEMALE DIE OPENINGS APPROX. 8 TIMES METAL THICKNESS, WITH RADIUS ON MALE DIE EQUAL TO METAL THICKNESS, AND ARE CONSIDERED IDEAL FOR RIGHT ANGLE BENDING.

BENDING PRESSURES REQUIRED FOR OTHER METALS AS COMPARED TO 65,000 P.S.I. TENSILE MILD STEEL ON CHART:

SOFT BRASS.....50% OF PRESSURE LISTED  
 SOFT ALUMINUM.....50% OF PRESSURE LISTED  
 ALUMINUM ALLOYS (Heat Treated)...SAME AS STEEL  
 STAINLESS STEEL.....50% MORE THAN STEEL  
 CHROME MOLYBDENUM.....100% MORE THAN STEEL

FIGURE 20

## **7.4 6 X 6 NINETY DEGREE NOTCHER**

The six inch (152mm) ninety degree notcher is a component tool designed to make square and vee notches in angle iron and flat stock. The maximum capacity of the tool is 3 x 3 x 1/4" (76 x 76 x 6mm) or 6 x 6 x 1/8" (152 x 152 x 3mm). The selector switch must be in the SHEAR position to operate this tool.

### **7.4A 6 X 6 NINETY DEGREE NOTCHER INSTALLATION**

SEE FIGURE 21 ON THE FOLLOWING PAGE.

TO INSTALL THE NOTCHER ON THE TOOL TABLE, the tool should be mounted as close to the frame as possible and anchored through the bottom of the notcher casting, as shown, with bolts and washers provided.

⊗ **CAUTION:** CAUTION: CARE MUST BE TAKEN TO SET THE UPPER AND LOWER STROKE CONTROLS. FAILURE TO SET THE STROKE CONTROLS WILL RESULT IN DAMAGE TO THE TOOL AND POSSIBLE INJURY TO THE OPERATOR.

The upper stroke should be set so that the pusher assembly is held in place by the spring tension of the tool. The lower stroke must be set so that the upper blade just passes the lower blades at the point of the vee by no more than 1/16 of an inch (1.5mm).

### **7.4B 6 X 6 NINETY DEGREE NOTCHER OPERATION**

Lubricate the blades before starting and every 10 to 15 cuts, thereafter. Oil the pressure block every two hours of operation. Do not attempt to shear material thicker than 1/4 inch (6mm) and never side load the notcher. The slug must be removed after every cut. Remove the slug with a magnetic probe or tongs.

➡ **DO NOT REMOVE THE SLUGS BY HAND!**

⊗ **CAUTION:** ALWAYS REMOVE THIS TOOL WHEN IT IS NOT IN USE.

### **7.4C BLADE REPLACEMENT**

The lower blades are symmetrical and can be rotated to expose four cutting edges. The upper blade has two cutting edges.

TO ROTATE OR REPLACE THE BLADES, USE THE FOLLOWING STEPS:

⊗ **CAUTION:** THE UPPER CASTING OF THE NOTCHER IS HEAVY ENOUGH TO CAUSE INJURY IF DROPPED. USE CARE WHEN HANDLING THIS TOOL.

1. Remove the return springs from the unit.
2. To allow further adjustments, rotate or replace the upper blade and snug bolts, only.
3. Rotate or replace the lower blades.
4. Lower the upper blade down until it just passes the lower blade, approximately 1/16 inch (1.5mm).
5. Adjust the upper blade until the point almost touches the lower blades.
6. Center the rear of the upper blade with the lower blades. There should be a clearance of approximately .005 of an inch (.12mm) on each side.

**NOTE:** If tool ever jams or gets stuck - REMOVE THE TOOL FROM THE MACHINE BEFORE ATTEMPTING TO FREE IT.

7. Tighten the upper blade bolts. Raise and lower the upper casting several times by hand, to check blade alignment. After alignment, tighten the back up set screws, making sure that the upper blade does not move.

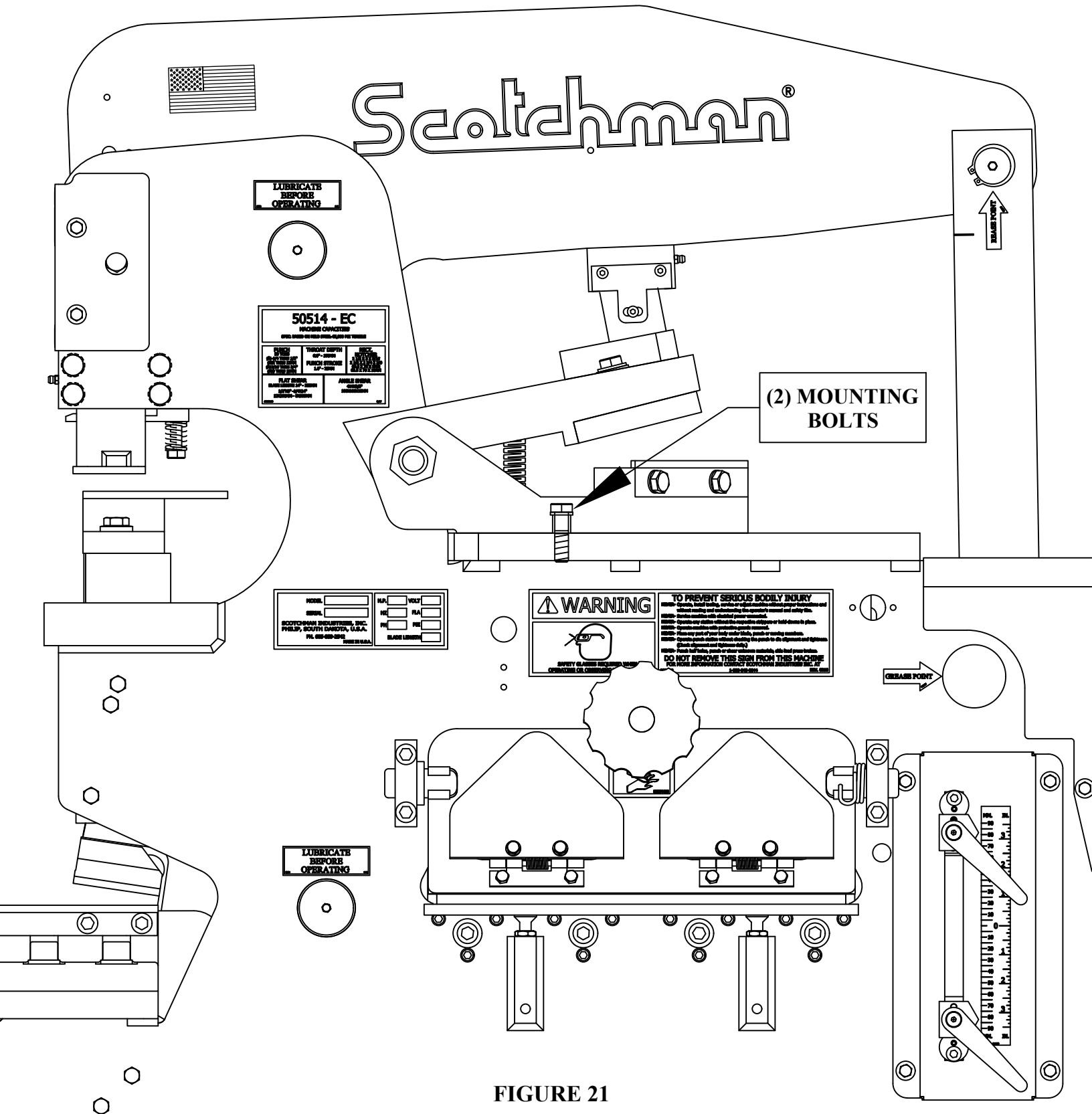

FIGURE 21

## 7.5 PIPE NOTCHER

The pipe notcher is a component tool designed to saddle cut pipe or tubing for applications such as railings. There are dies available to notch angles in tubes and pipe, also. For prices and availability, contact your local dealer or the factory.

### 7.5A PIPE NOTCHER INSTALLATION

SEE FIGURE 22 BELOW.

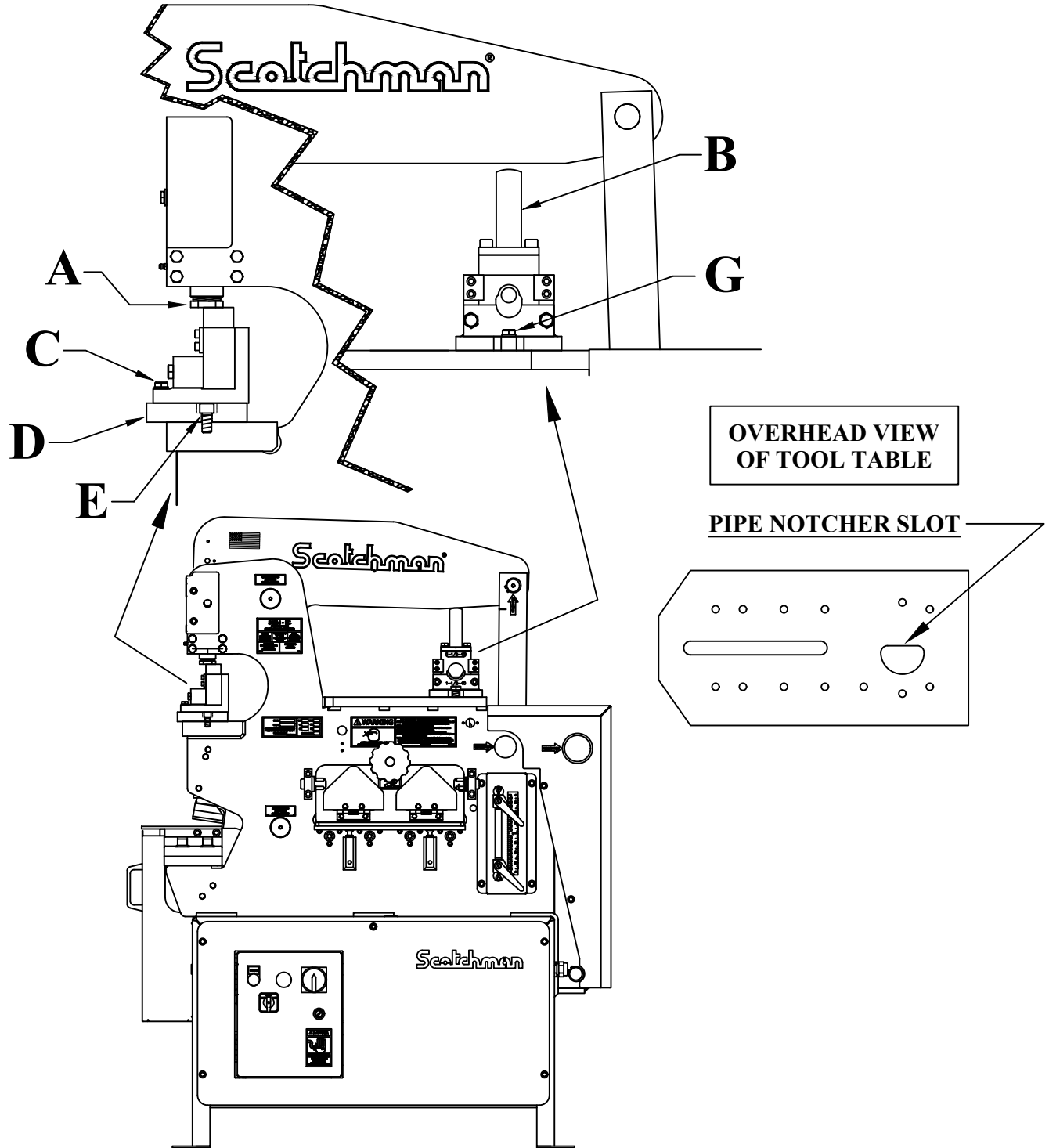

FIGURE 22

The Pipe Notcher can be installed in either the punch station or on the tool table. When installed in the punch station, the selector switch must be in the PUNCH position. When installed on the tool table, the selector switch must be in the SHEAR position.

**TO MOUNT THE PIPE NOTCHER IN THE PUNCH STATION:**

1. Remove the die holder, die holder plate, stripper, punch and punch retaining nut.
2. Install the Punch Pusher (A) in the punch barrel.
3. Install the riser plate (D) on the punch bolster and anchor it with the bolts (E) provided.
4. Install the return springs, the upper die and the lower die in the pipe notcher housing.
5. Mount the pipe notcher so that the cutting dies face away from the machine. Use the bolts provided to anchor the tool in place. Align the tool over the slug hole in the bolster, to assure proper slug removal.

**NOTE: THE PUNCH PUSHER WILL NOT ALIGN DIRECTLY OVER THE PIPE NOTCHER. THIS IS OKAY.**

**TO MOUNT THE PIPE NOTCHER ON THE TOOL TABLE:**

1. Install the return springs, the upper die and the lower die in the housing.
2. Bolt the Beam Pusher (B) to the upper die.
3. Place the tool on the right hand side of the tool table, with the cutting dies facing the operator's side of the machine.
4. Align the slug slot in the tool with the slot in the tool table. Anchor the tool with one of the angle shear mounting bolts (G).

**CAUTION: WITH THE TOOL MOUNTED IN EITHER STATION, IT IS NECESSARY TO SET THE DOWNSTROKE OF THE MACHINE TO PREVENT DAMAGE TO THE TOOL. THE UPPER DIE SHOULD NOT PASS THE LOWER DIE BY MORE THAN 1/32 OF AN INCH (.7 MM).**



## **7.5B PIPE NOTCHER OPERATION**

The pipe notcher used to be a vendor item for Scotchman Industries. It is now manufactured here, in house. The following are some recommendations for the maintenance and alignment of this tool.

**PLEASE READ CAREFULLY BEFORE USE OF TOOLING.**

**TO ACHIEVE THE BEST RESULTS FROM YOUR UNIT, please observe these simple rules.**

- A. Keep the unit clean. Whenever dirt or metal chips accumulate, remove the 8mm limit screw located in the center, at the rear of the punch. Lift out the punch holder and the two springs. Clean the unit with solvent.**
  
- B. Never remove the M-10 dowel pin from the upper die (Vendor Item). Generally, it should not be necessary to remove the set screw that holds the insert in the top die (Scotchman product).**
  
- C. Check the alignment of the unit. After cleaning the unit, always check the alignment of the punch and die. To check the alignment, insert the punch and die holder, without the springs, into the housing and check the gap.**

**SEE FIGURE 23 ON THE FOLLOWING PAGE.**

**If proven correct, tighten the two M-10 socket head screws holding the lower die section in place.**

**Apply some high pressure lube all around the inside of the housing.**

**Re-assemble the unit, reversing the above procedures.**

**Before operating, lubricate the back and sides of the upper die with way oil.**

**Repeat this lubrication once daily.**

**Apply cutting oil or motor oil to the cutting dies before the first cut and every 10 to 15 cuts, thereafter.**

<p><b><u>NOTE:</u> If tool ever jams or gets stuck - REMOVE THE TOOL FROM THE MACHINE <u>BEFORE</u> ATTEMPTING TO FREE IT.</b></p>
--

## 7.5C PIPE NOTCHER CAPACITIES

Two inch (2") schedule 40 pipe is the maximum thickness that can be cut.

Lighter weight tubing may be cut but will probably require different dies for best cutting results.

Separate dies are required for each size of pipe or tubing being notched.

⊠ CAUTION: ALWAYS REMOVE THIS TOOL WHEN IT IS NOT IN USE.

## PIPE NOTCHER DIE ALIGNMENT

**CORRECT**

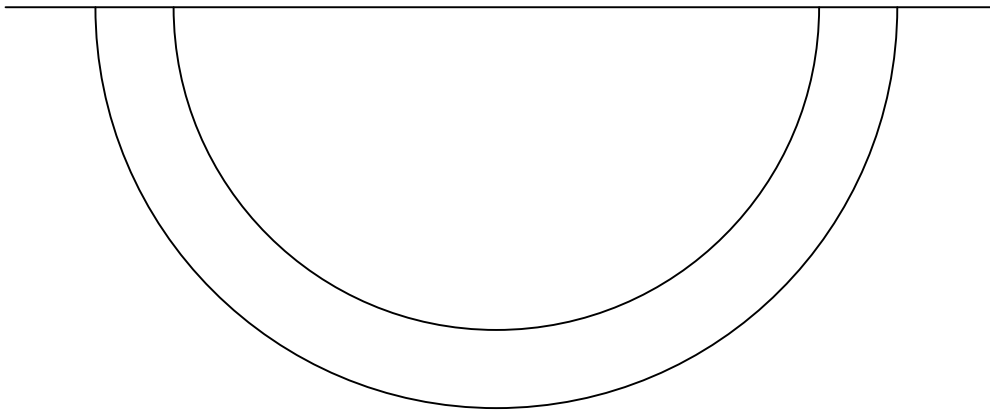

**INCORRECT**

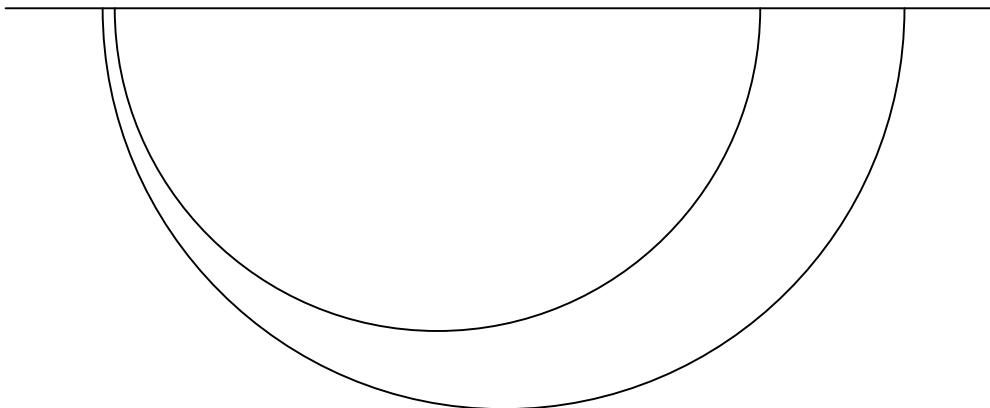

**FIGURE 23**

## 7.6 PICKET FENCE TOOL

The picket fence tool is designed to make picket points on square tubing, for ornamental fence applications. The tool has a maximum capacity of 1 inch (25mm).

### 7.6A PICKET FENCE TOOL INSTALLATION

SEE FIGURE 24 BELOW.

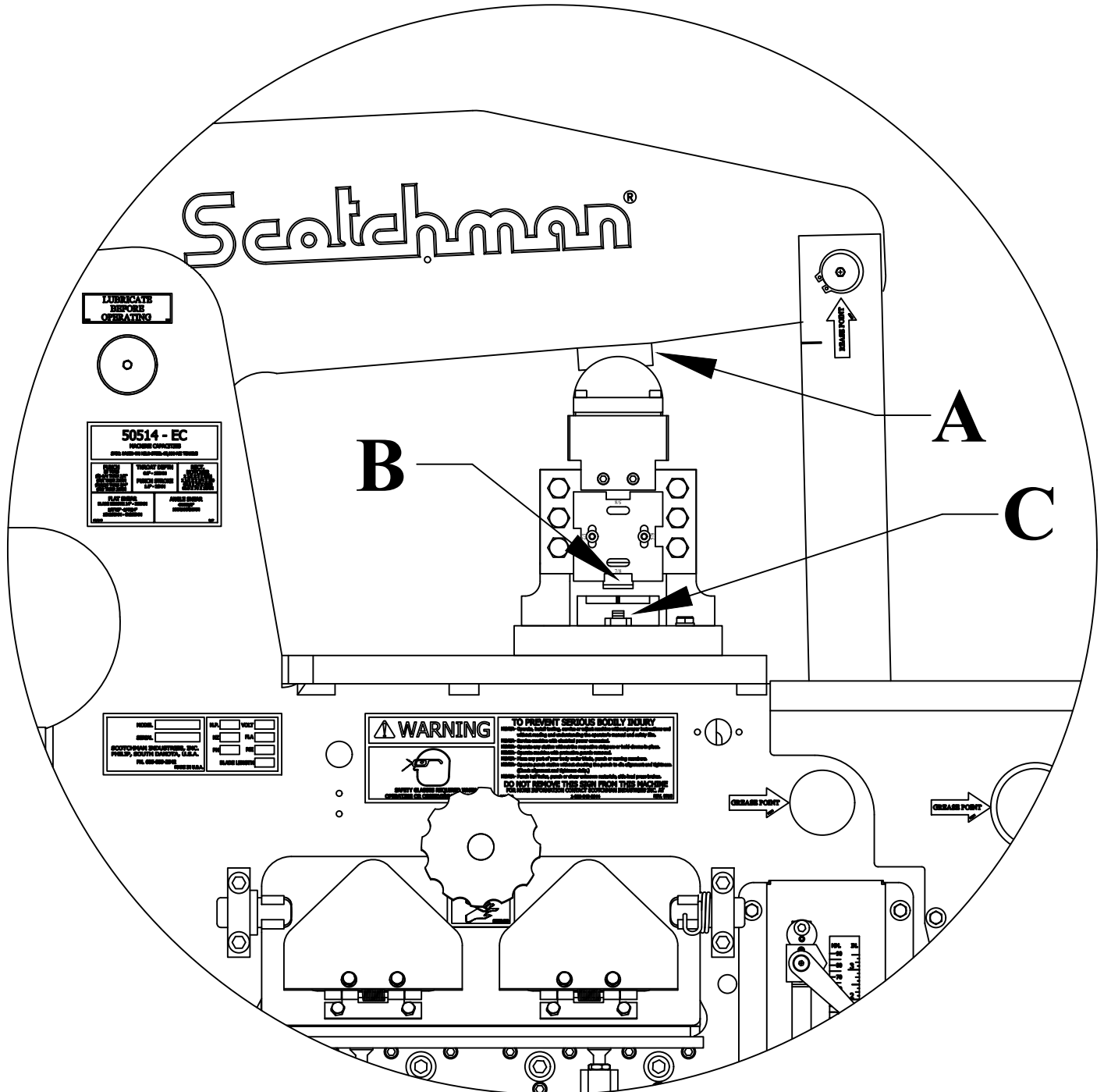

FIGURE 24

**This tool mounts on the tool table in place of the angle shear and is anchored with the same bolts.**

**Lubricate the pressure block (A), top and bottom, before installing it on the tool. Grease the pressure block every two hours of operation.**

**The upstroke of the machine must be set to maintain spring tension on the pressure block at all times.**

**The selector switch must be in the SHEAR position to operate this tool.**

## **7.6B PICKET FENCE TOOL OPERATION**

- 1. Set the down stroke of the machine so that the upper die clears the lower die by twice the wall thickness of the tube, plus 1/32 of an inch (.8mm).**
  - 2. Position the tube guide for the size of tubing you are using.**
- ▶ NOTE: THE PLATE MUST BE REMOVED WHEN PUNCHING ONE INCH TUBE.**
- 3. Adjust the tube stop (B) just low enough to contact the upper edge of the tube.**
  - 4. Adjust the rest stop (C) so that it is approximately half of the tube size below the lower die.**
  - 5. Feed the tube into the tool until it contacts the stop (B). Depress the shear pedal.**
  - 6. Lubricate the dies every 10 to 15 cuts and grease the ram daily.**

<p><b><u>NOTE:</u> If tool ever jams or gets stuck - REMOVE THE TOOL FROM THE MACHINE <u>BEFORE</u> ATTEMPTING TO FREE IT.</b></p>
--

**⊗ CAUTION: ALWAYS REMOVE THIS TOOL WHEN IT IS NOT IN USE!**

## 7.7 SQUARE TUBE SHEAR

The square tube shear is designed to shear square tubing from 1/4" to 1" (6mm to 25mm). 16 gauge (.060" or 1.5mm) is the maximum material thickness.

### 7.7A SQUARE TUBE SHEAR INSTALLATION

SEE FIGURE 25 ON THE FOLLOWING PAGE.

The tool mounts on the tool table in place of the angle shear and is anchored with the same bolts. Lubricate the pressure block (A) before installing the tool and after every two hours of operation. Set the up stroke of the machine so that the size of tube you want to shear will feed through the tool. Make sure that the up stroke is set so that there is spring tension on the pressure block at all times.

### 7.7B SQUARE TUBE SHEAR OPERATION

1. The selector switch must be in the SHEAR position to operate this tool.
2. Set the down stroke of the machine so that the upper blade passes the lower blade by approximately 1/8 of an inch (3mm).
3. Feed the tubing through the shear to the desired length and depress the foot pedal.
4. Lubricate the blades every ten to fifteen cuts.

⊗ **CAUTION:** ALWAYS REMOVE THIS TOOL WHEN IT IS NOT IN USE.

### 7.7C ANGLE IRON BRAKE INSTALLATION

This tool is also referred to as an Open End Brake; part number 1365 Pressure Cap Assembly. (A) is to be mounted on the upper brake die with the two set screws (B) provided. Use the M-12 x 55 bolt (C) and M-12 flat washer (D) to bolt the tool to the tool table, as shown in Figure 24-2 on the following page. It is mounted to the right of the angle shear. Make sure that the pressure cap (A) is squarely under the punch beam. Clamps are sent, but not needed, with this machine.

### 7.7D ANGLE IRON BRAKE OPERATION

1. Grease the guide post every two hours of operation. There are two grease zerks, one on each side of the guide post.
2. The recommended die size is 8 eight times the thickness of the material. The brake is supplied with two 1" dies, as standard equipment. The maximum recommended material with the standard dies is 1/4" (6mm) thick.
3. NEVER put your hands into or around this brake when it is in operation! Hold short pieces with tongs or a similar device.
4. If the brake should become jammed for any reason, DO NOT ATTEMPT TO FREE IT BY HAND. Use a pry bar to free it and repair or replace whatever caused the jam. Sticking of the brake can be caused by the complexity of the part, lack of lubrication or interference between the guide and post.

**NOTE:** If tool ever jams or gets stuck - REMOVE THE TOOL FROM THE MACHINE BEFORE ATTEMPTING TO FREE IT.

⊗ **CAUTION:** ALWAYS REMOVE THIS TOOL WHEN IT IS NOT IN USE.

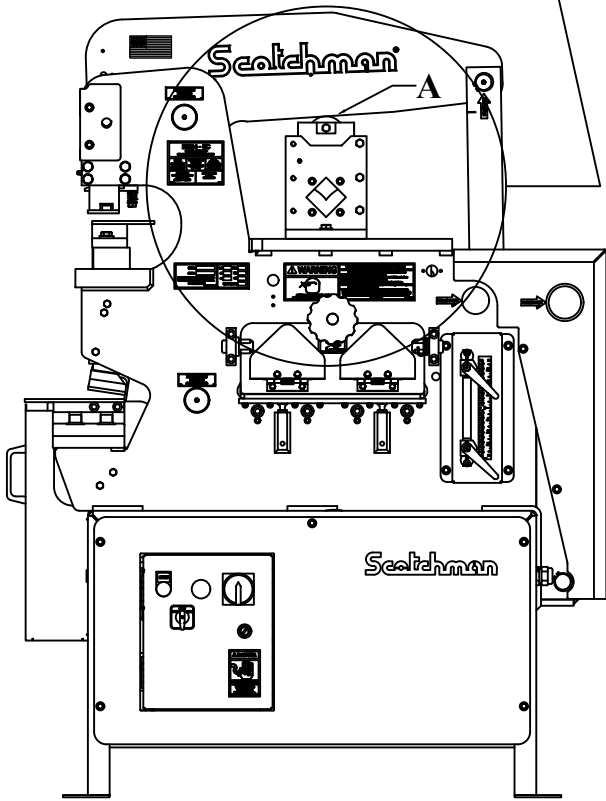
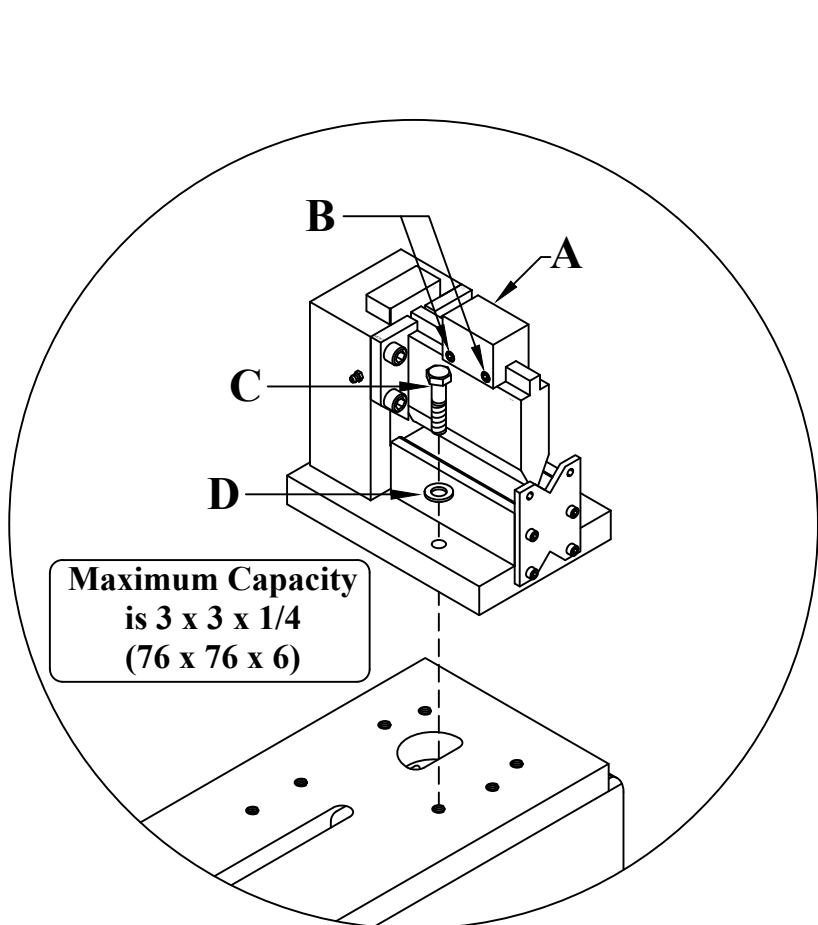
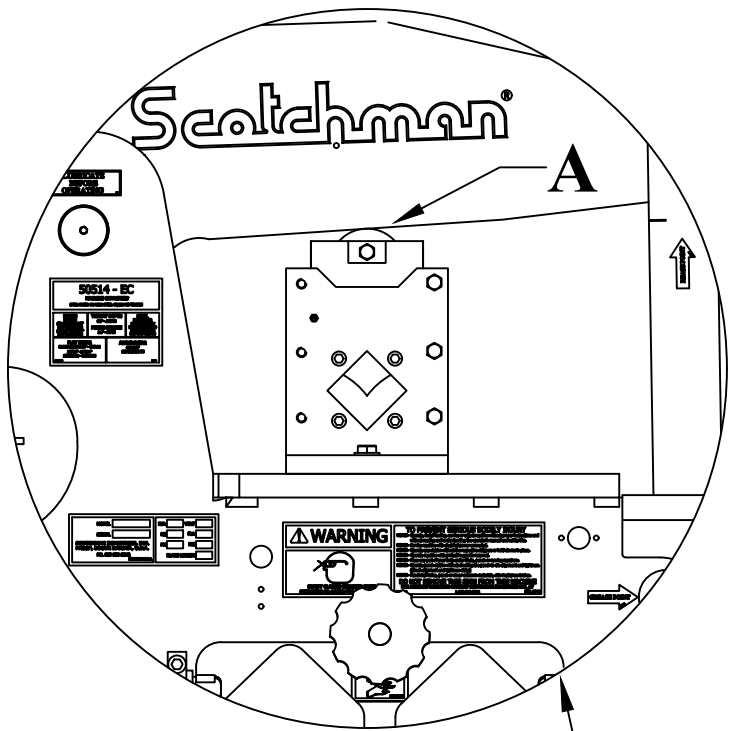

**Square Tube Shear**

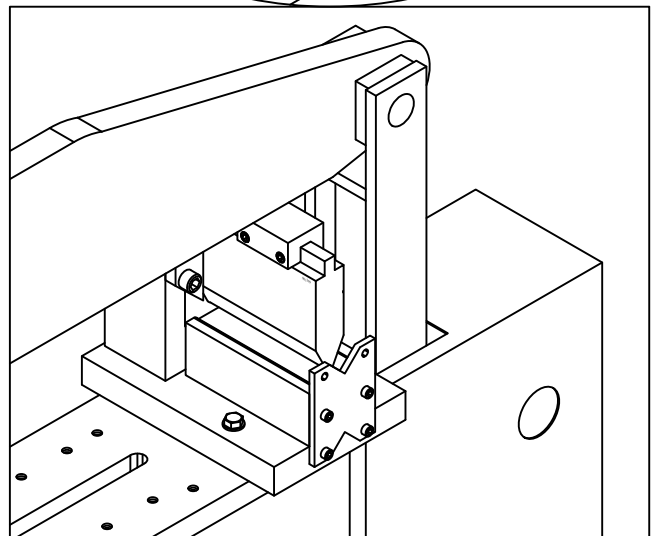

**Angle Iron Brake**

**FIGURE 25-1**

**FIGURE 25-2**

## 7.7E MULTI-SHEAR TOOL

The multi-shear tool is designed to shear standard Unistrut profiles, as well as many other specialty profiles.

## 7.7F MULTI-SHEAR TOOL INSTALLATION

SEE FIGURE 26 ON THE FOLLOWING PAGE.

If the punch and die are mounted on the machine, remove them.

1. Turn the machine on and put it in the SHEAR position.
2. Place the tool on the tool table under the punch beam, keeping it towards the punch end of the tool table.
3. Locate the clamp (B) and the bolts and washers (C) and loosely mount the tool to the fourth set of holes from the left on the tool table.

**DO NOT** place the Multi-Shear Tool any further towards the rear of the machine due to possible "bottoming out" condition.

4. Make sure the tool is located under the beam correctly by aligning the pressure cap (A) under the beam. Once the tool is squarely under the beam, tighten the bolts (C) for the clamp (B) to hold it in place.
5. Set the upstroke of the machine so that the size of material you want to shear will feed through the tool.
6. Make sure that the upstroke is set so that there is spring tension on the pressure block at all times.
7. Set the down-stroke of the machine so that the moving blade travels only far enough to shear the material and no further.

## 7.7G MULTI-SHEAR TOOL OPERATION

1. The selector switch must be in the SHEAR position to operate this tool.
2. Set the down-stroke of the machine so that the moving blade travels only far enough to shear the material and no further. "Bottoming out" this tool may ruin it!
3. Feed the material through the shear to the desired length and depress the foot pedal.
4. Grease the pressure cap (A) before using and every two hours, thereafter.
5. Lubricate the blades every ten to fifteen cuts.

**NOTE: If tool ever jams or gets stuck - REMOVE THE TOOL FROM THE MACHINE BEFORE ATTEMPTING TO FREE IT.**

⊗ **CAUTION: ALWAYS REMOVE THIS TOOL WHEN IT IS NOT IN USE.**

**NOTE: See-Thru Guard is for Clarity**

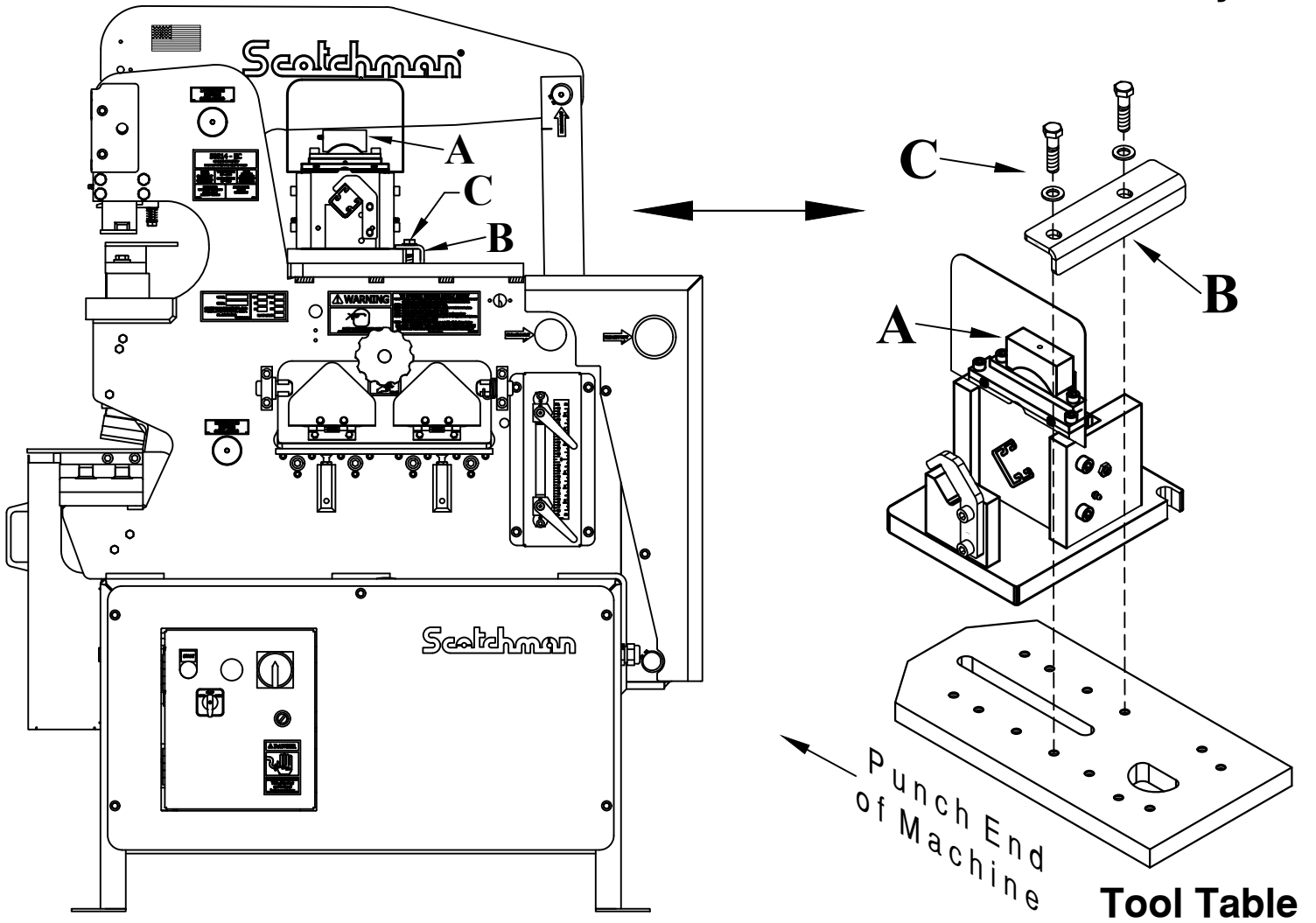

**FIGURE 26**



## **7.7H WELD COUPON BENDER TOOL**

The Weld Coupon Bender tool is designed to bend welded test clips into "U" and "V" shapes for the purpose of testing the soundness and ductility of welds.

The maximum size of a test clip is 7 x 2 x 3/8" (178 x 51 x 10mm) thick. Rollers are 4" (102mm) apart.

## **7.7I WELD COUPON BENDER TOOL INSTALLATION**

SEE FIGURE 27 ON THE FOLLOWING PAGE.

The Weld Coupon Bender tool mounts on the tool table under the upper arm and is held in place with two M-12 bolts and flat washers (A). Use the 4th set of holes from the left (punch end) on the Tool Table and mount as shown in the drawing.

Make sure that the Rocker Cap (B) is squarely under the arm and that the stationary back of the Coupon Bender is clear of the moving arm of the ironworker.

The down-stroke must be set properly with this tool. On the left side of the tool, under the roller, there are two lines machined in the tool's back support. The upper line is for when the "V" die is used and the lower line is for when the "U" die is used. The stroke is to be set by aligning the bottom of the ram with the appropriate line machined in the back support. Please see the drawing under "Setting the Stroke".

## **7.7J WELD COUPON BENDER TOOL OPERATION**

1. Grease the rocker cap (B) between the upper arm and the tool and again after every two hours of use. Grease the ram, using the two grease zerks on the side.
2. Lightly grease the rollers, using the two grease zerks on the front of the weld tester. Make sure that the rollers still turn easily. Too much grease can cause the tool to not work properly.
3. Lightly lubricate the underside of the die and the outside of the two rollers with a spray lube such as WD-40 and again, every 10-15 bends, thereafter.
4. Insert the weld test coupon by sliding it on to the rollers. Using the back of the weld tester, square up the test piece and then, move it forward enough to center it under the die. Make sure that the weld test coupon is square and centered under the die.
5. Make sure that the down stroke of the tool is set so that the bottom of the ram - NOT the die - is aligned with the correct scribe line.
6. After bending the weld test coupon, let the tool return to the resting position. Remove the test coupon and inspect the weld.

**NOTE: If tool ever jams or gets stuck - REMOVE THE TOOL FROM THE MACHINE BEFORE ATTEMPTING TO FREE IT.**

⊠ **CAUTION: ALWAYS REMOVE THE WELD COUPON BENDER WHEN IT IS NOT IN USE.**

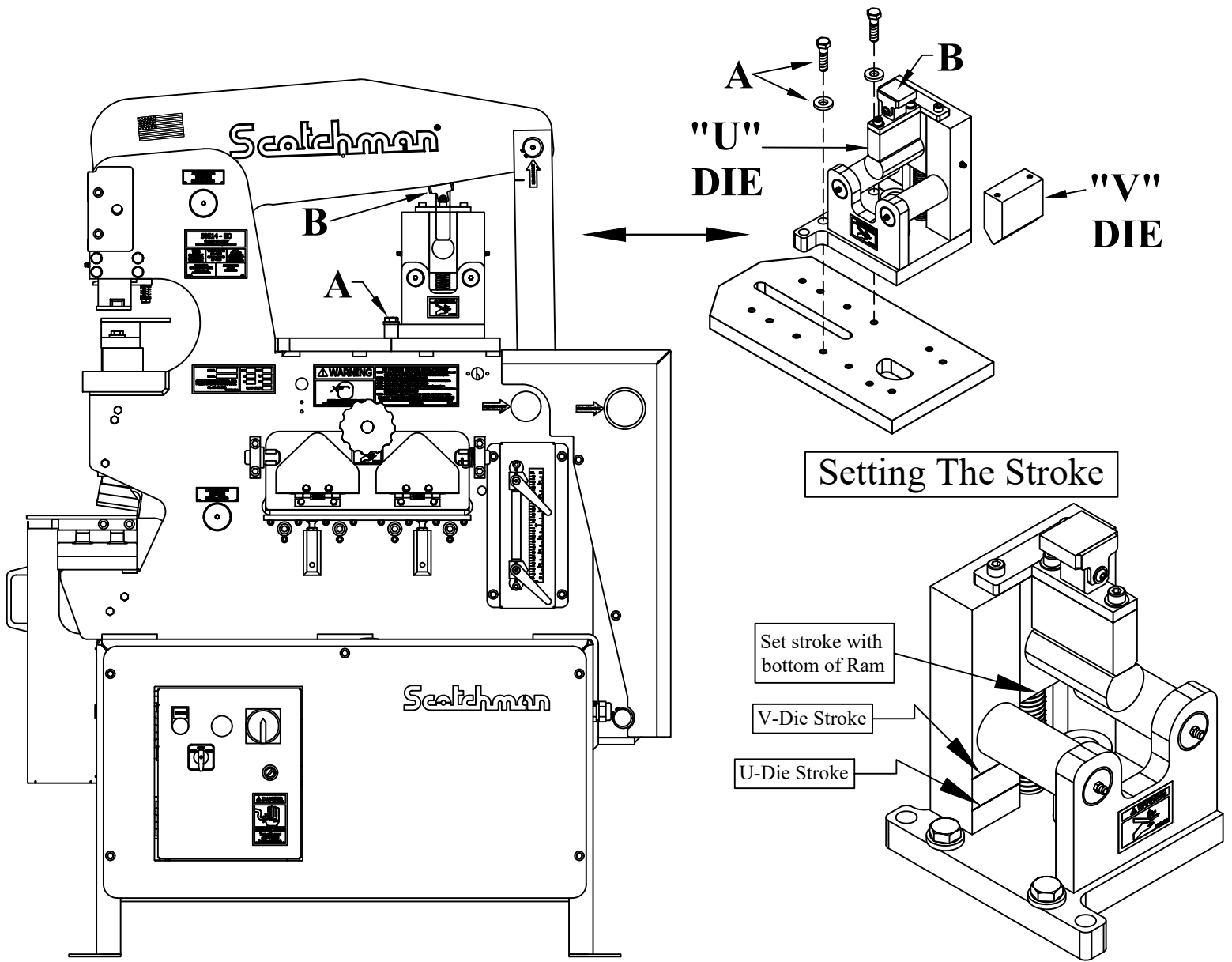

FIGURE 27

## **7.8 OPTIONAL DIE HOLDERS AND STRIPPERS**

### **7.8A 2-5/8 INCH (66 MM) DIE HOLDER**

The optional 2-5/8 inch (66mm) die holder is of the same design as the standard die holder. It is used in oversized punching applications. FOR APPLICATIONS, SEE THE TOOLING MANUAL.

Always use the preferred method of aligning punches and dies. REFER TO SECTION 6.1.

### **7.8B 4 X 6 DIE HOLDER**

The 4 x 6 inch die holder is used in oversize punching applications.

FOR APPLICATIONS, SEE THE TOOLING MANUAL.

Always use the preferred method of aligning punches and dies referred to in SECTION 6.1.

### **7.8C OPTIONAL STRIPPER**

The optional stripper is used in oversize punching applications. FOR APPLICATIONS AND PARTS IDENTIFICATION, REFER TO THE TOOLING MANUAL.

## **7.9 OPTIONAL GAUGING EQUIPMENT**

### **7.9A FORTY-EIGHT INCH BACK GAUGE**

SEE FIGURE 28 ON THE FOLLOWING PAGE.

The 48 inch back gauge is an optional back gauge used as a length stop. It mounts to the drop-off side of the machine and is capable of reaching all stations of the machine from one location. All machines are tapped for this option; it can be added at any time.

### **7.9B GAUGING TABLE-BAR SHEAR**

The optional gauging table is designed to mount in place of the standard table on the bar shear.

It is an extended table with a built-in guide for quick set up of miter and straight cuts.

FOR PARTS IDENTIFICATION, REFER TO THE TOOLING MANUAL.

### **7.9C ANGLE MITER GUIDE**

There is an optional miter guide for the angle shear. The guide has stops set at 22° and 45°.

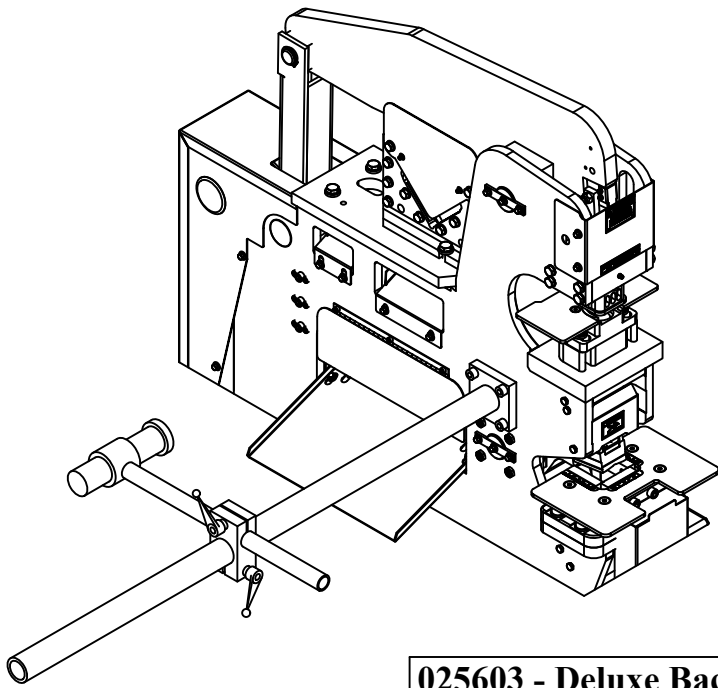

**Best Place for Stop  
to Contact Material  
Shown Below**

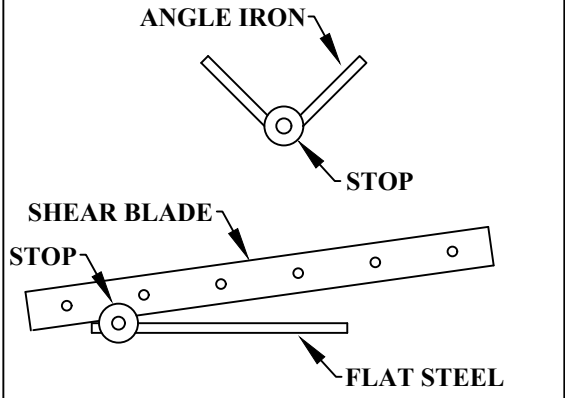

**025603 - Deluxe Back Gauge 48" Parts List**

Item #	Qty	Part Number	Description
1	1	025324	Length Stop
2	2	219047	M10 x 12 Set Screw
3	1	025317	Length Stop Assembly
4	1	025320	Slide Block Length Stop
5	2	025361	M12 x 50 Adj. Handle
6	4	221420	M16 x 50 SHCS
7	1	025312	Stop Bar Assembly
8	1	029220	LH Tape 1/2" x12' R/L
9	1	080189	Allen Wrench

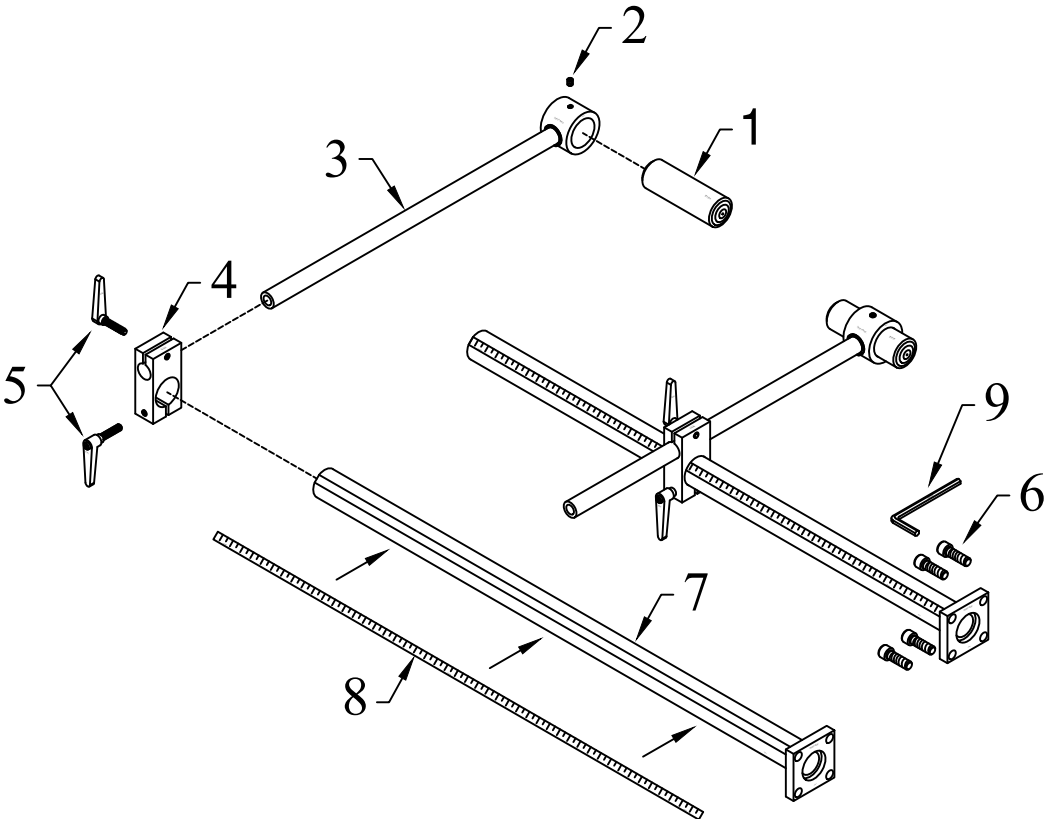

**FIGURE 28**

## **8.0 TROUBLE SHOOTING GUIDE**

### **8.1 ELECTRICAL TROUBLESHOOTING - MOTOR**

**⊗ CAUTION: ALL ELECTRICAL WORK PERFORMED ON THE 50514-EC IRONWORKER SHALL BE DONE BY A QUALIFIED ELECTRICIAN.**

**A. MOTOR WILL NOT RUN:**

- 1. Check to be sure that the disconnect switch is in the ON position and that the selector switch is in the START position.**
- 2. Check to be sure that plant voltage and phase correspond to the machine voltage and phase.**
- 3. Check the line wiring connections at the starter. For the wiring diagram, SEE FIGURE 4 ON PAGE 13.**
- 4. Check the primary and secondary fuses on the transformer.**
- 5. Check the line voltage at the starter. If the correct line voltage is present at the starter, either the starter or the motor is defective. Contact your local dealer or the factory.**

**B. MOTOR RUNS BUT THE MACHINE WILL NOT CYCLE WHEN DEPRESSING THE FOOT PEDAL:**

- 1. Check the motor rotation. It should be clockwise when facing the fan end of the motor.**
- 2. Check the selector switch. It must be in either the PUNCH or the SHEAR position or the machine will not move.**
- 3. If installed, check the RUN/JOG selector switch. It must be in the RUN position or the machine will not move when depressing the foot pedal.**
- 4. Check the stroke control adjustment and make sure that only one limit switch is in contact with the metering boss. If both limit switches are in contact with the metering boss, the machine will not move. Loosen the stroke control handles and move the limit switches. Try the machine again.**
- 5. Check the fuses in the control box. There are two fuses in line on the primary side of the transformer and one on the secondary side. Remove the fuses and check them with an Ohm meter and replace them, if necessary. Use a Bussman FNQ-R1 600 volt or equivalent for the primary side. Use a Bussman FNM-2 or equivalent for the secondary side.**
- 6. Check the limit switches. (For procedures, REFER TO SECTION 8.2.)**
- 7. No power from the transformer: Check the voltage across the transformer's secondary terminals. It should read 110 to 120 volts.**
- 8. The solenoid on the control valve is not functioning: REFER TO SECTION 8.3.**
- 9. The foot pedal switch is not functioning properly: A voltage test may be run on the terminal strip in the control box to determine if the foot-switch is working properly.**

**⊖ WARNING: THERE IS LINE VOLTAGE PRESENT IN THE CONTROL BOX WHEN THE MACHINE IS POWERED. THESE TESTS SHOULD BE PERFORMED BY A QUALIFIED ELECTRICIAN.**

**TO TEST THE FOOT SWITCH, place the selector switch in the START position and power the machine. Place the selector switch in the PUNCH or the SHEAR position and test the voltage between terminal #'s x2 & 5 and x2 & 10. With the pedal up, the voltage should read 110-120V between #'s x2 & 5. There should be no voltage reading between #'s x2 & 10. With the pedal depressed, the voltage should read 110-120V between #'s x2 & 10. There should be no voltage reading between #'s x2 & 5. If these readings are not correct, continue on with the following steps:**

- A. Turn the machine's power off at the disconnect switch. Remove the cover on the foot switch and check for any loose connections.**
- B. Make sure that the switches are adjusted properly. (You should hear two distinct "clicks" when depressing the pedal.) There is a set screw adjustment on the pedal shaft to adjust the switches.**
- C. Check the switches with an Ohm meter.**
- 9. Damage to the foot pedal cord: Check the continuity of the wire in the cord with an Ohm meter. Make sure that the power to the machine is off and locked out. The wires must be disconnected from the pedal and the terminal blocks.**

## **8.2 LIMIT SWITCH INSPECTION**

**The limit switches are sealed units and cannot be taken apart. The plunger can be manually checked. It should move freely in and out. The switches can also be tested with an Ohm meter.**

**The wires must be disconnected from the terminal blocks and the power to the machine off.**

**With the plunger out, the switch should read continuity; with the plunger depressed, it should read open.**

## **8.3 CONTROL VALVE INSPECTION**

**THE MACHINE WILL ONLY TRAVEL IN ONE DIRECTION.**

**THIS COULD BE CAUSED BY:**

- A. Contamination in the hydraulic oil which causes the spool to stick in one position. With the machine's power off, the spool of the valve can be manually shifted. On each end of the control valve, there is a pin in the center of the knurled nut that holds the coil on. To shift the spool manually, use a small punch or similar device to push these pins in by hand, first one and then, the other. Turn the machine on and try it again. If the machine now operates, the hydraulic oil and the filter should be changed.**
- B. A defective coil on the control valve: The coils can be checked by using an Ohm meter. The wires to the coils must be disconnected. If the ohm reading shows open, the coil is defective and must be replaced.**

## **8.4 HYDRAULIC**

### **THE MOST COMMON HYDRAULIC PROBLEMS ARE:**

- 1. Low level of hydraulic fluid in the reservoir: The reservoir holds 4 U.S. Gallons (15 liters). The level should be 1 inch (25mm) below the top of the reservoir.**
- 2. Low pressure caused by worn or damaged parts in the cylinder or pump: There is a pressure port provided on the machine to check the system pressure. There is a gauge port in the hydraulic manifold. A pressure gauge with a quick coupler and a minimum of three thousand (3,000) P.S.I. is required. With the machine.s power off, install the pressure gauge. Power the machine and place a piece of steel in the shear section and clamp it down with the hold down device. Attempt to shear the piece, watching the gauge for a reading. The system pressure of this machine is 2,350 P.S.I. (162 BAR). The pressure adjustment is on the manifold. Turning the adjusting screw in should increase the pressure. If the pressure cannot be adjusted, contact your local dealer or the factory.**

**⊗ CAUTION: NEVER SET THE PRESSURE OF THE MACHINE ABOVE 2,350 P.S.I. (162 BAR).**

## **8.5 CYLINDER SEAL REPLACEMENT**

### **USE THE FOLLOWING STEPS TO REPLACE THE SEALS IN THE HYDRAULIC CYLINDER: SEE FIGURE 29 ON THE FOLLOWING PAGE.**

- 1. With the selector arm in the SHEAR position and the arms up, turn the machine.s power OFF at the disconnect switch and lock it.**
- 2. Block the arms up, either on the tool table or under the shear arm. SEE ITEM (A).**
- 3. Remove the hoses from the cylinder and allow the fluid to drain.**
- 4. Remove the cylinder clevis pin (B) and swing the cylinder out away from the arm. The cylinder head is threaded into the tube. Use a pin wrench to unscrew the head.**
- 5. Tap the cylinder head (E) down into the tube far enough to remove the second retaining ring (D).**
- 6. Place the pin (B) through the clevis and pull the cylinder apart, using a come-along or similar device.**
- 7. Remove the locking nut from the end of the shaft and slide the piston and head off of the shaft.**
- 8. Replace all of the seals. There will be extra seals in the kit. Match the replacement seals with the old ones and discard the rest.**
- 9. Clean all parts, including the inside of the tube, and check all parts for nicks or scratches.**
- 10. Oil all of the seals before reassembling the cylinder.**
- 11. After the head and piston are assembled on the shaft, torque the locking nut to 100 ft. lbs. (136 N•m)**

12. Tap the shaft assembly back into the tube, using a brass or plastic hammer.
13. Thread the cylinder head back into the tube.
14. Replace the cylinder clevis pin (B) and connect the hoses to the cylinder.
15. Use care when removing the block (A). The cylinder does not have fluid in it and the arms may drop some when the block is removed.
16. Cycle the machine several times before performing any work

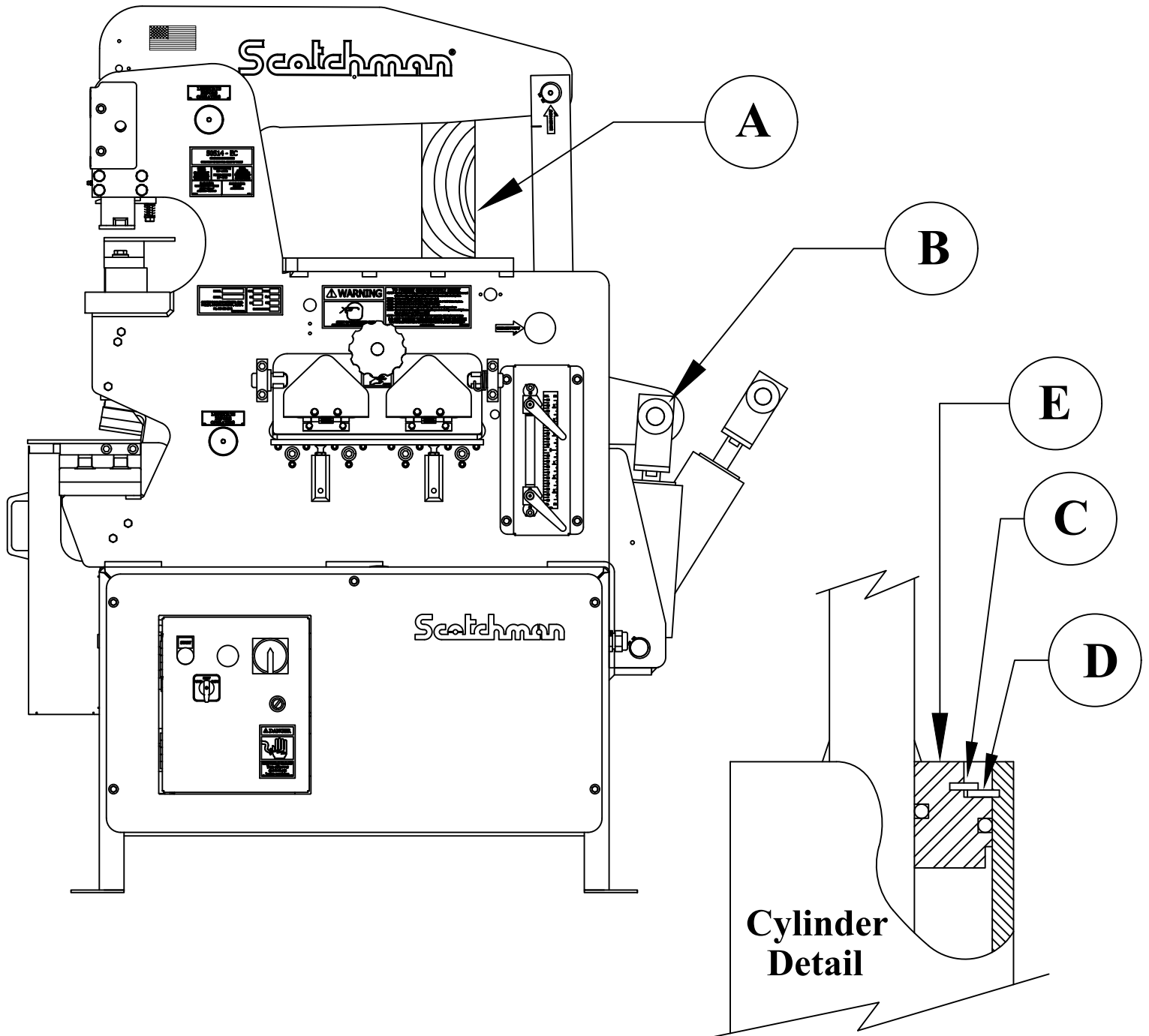

FIGURE 29



## **9.0 MACHINE PARTS LISTS**

The Following Section Contains The Ironworker Parts Lists And Drawings.

For Your Own Convenience, Always Give Your Complete Serial Number When Ordering Parts.

### **9.1 PUNCH ASSEMBLY**

<b>ITEM</b>	<b>PART #</b>	<b>DESCRIPTION</b>
<b>A</b>	<b>402290</b>	<b>Drag Link</b>
<b>B</b>	<b>205425</b>	<b>M-12 HHCS</b>
<b>C</b>	<b>215014</b>	<b>M-12 Greer Nut</b>
<b>D</b>	<b>312361</b>	<b>Spring Clip</b>
<b>E</b>	<b>234008</b>	<b>M-5 HN</b>
<b>F</b>	<b>073458</b>	<b>M-6 SHCS</b>
<b>G</b>	<b>233315</b>	<b>M-5 RHMS</b>
<b>H</b>	<b>412311</b>	<b>Pressure Block</b>
<b>I</b>	<b>400615</b>	<b>Punch Barrel</b>
<b>J</b>	<b>530048</b>	<b>Punch Barrel Guide</b>
<b>K</b>	<b>203455</b>	<b>M-12 HHCS</b>
<b>L</b>	<b>208014</b>	<b>M-12 Hex Nut</b>
<b>M</b>	<b>000624</b>	<b>Punch Jam Nut</b>
<b>M1</b>	<b>000628</b>	<b>Jam Nut Wrench</b>
<b>N</b>	<b>401479</b>	<b>Stripper Clip</b>
<b>O</b>	<b>401490</b>	<b>Stripper</b>
<b>O1</b>	<b>001580</b>	<b>Complete Stripper (Includes N, O, P, Q, R &amp; S)</b>
<b>P</b>	<b>016120</b>	<b>3/4 x 1 Die Spring</b>
<b>Q</b>	<b>201220</b>	<b>M-10 HHCS</b>
<b>R</b>	<b>401492</b>	<b>Stripper Plate</b>
<b>S</b>	<b>230005</b>	<b>FSHCS</b>
<b>T</b>	<b>400726</b>	<b>Punch Plate</b>
<b>U</b>	<b>230107</b>	<b>M-8 FSHCS</b>
<b>V</b>	<b>401470</b>	<b>Die Holder (Includes U)</b>
<b>W</b>	<b>500082</b>	<b>Die Holder Spacer</b>
<b>X</b>	<b>205435</b>	<b>M-12 x 80 HHCS</b>
<b>Y</b>	<b>162005</b>	<b>Washer Reid</b>
<b>Z</b>	<b>532011</b>	<b>Punch Beam (Includes AA, D &amp; H)</b>
<b>AA</b>	<b>012304</b>	<b>Bushing</b>
<b>BB</b>	<b>531173</b>	<b>Punch Pin</b>
<b>CC</b>	<b>531176</b>	<b>Pin Lock Strap</b>
<b>DD</b>	<b>224105</b>	<b>M8 X 16MM DIN-BN73 WLCS</b>

EE	224105
FF	155030
GG	341083
HH	530068
II	001546
JJ	219047
KK	243101

M8 X 16MM DIN-BN73 WLCS  
 Snap Rings  
 Connecting Link Pin  
 Connecting Link  
 Locking Pin  
 M-10 SS  
 M6 Grease Zerk

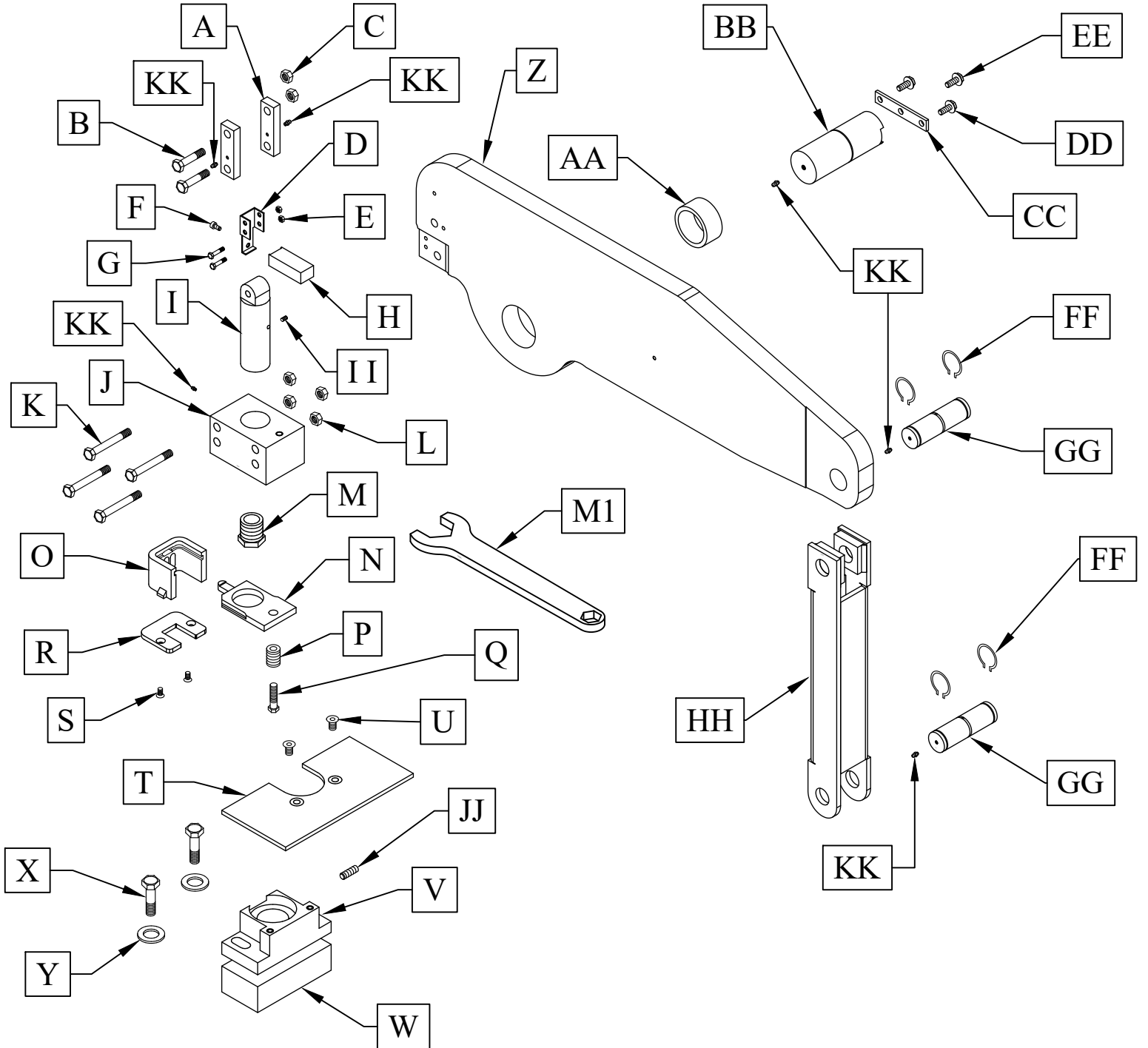

FIGURE 30

## 9.2 SHEAR ASSEMBLY

<b>ITEM</b>	<b>QTY</b>	<b>PART #</b>	<b>DESCRIPTION</b>
A	2	341025	Wear Plate - Shear Beam
B	1	080169	Bushing
C	1	532100	50 Ton Shear Beam Assy. (Includes B, R, & S)
D	1	531028	Pressure Plate
E	19	218120	M12 x 50 Set Screw
F	4	210014	M12 Jam Nut
G	1	341173	Shear Beam Pin
H	1	531176	Pin Lock Strap
I	2	224105	M8 X 16MM DIN-BN73 WLCS
J	1	224105	M8 X 16MM DIN-BN73 WLCS
K	2	243101	M6 Grease Zerk
L	4	214014	M12 Regular Flat Washer
M	4	221326	M12 x 65 HHCS
N	2	218122	M12 x 60 Set Screw
O	1	229410	M10 X 12 X 12 SB
P	2	221227	M10 x 55 SHCS
Q	1	532051	Wear Plate
R	1	422091	Beam Wear Plate
S	2	221145	M8 x 60 SHCS
T	2	155030	Retain Snap Ring
U	1	500096	Cylinder Clevis Pin
V	2	015333	Shear Blades
W	1	530034	Stroke Control Link
X	1	530035	Stroke Control Bushing
Y	2	220029	M10 x 35 BHCS
Z	1	510041	Shear Table
AA	4	221325	M12 x 55 SHCS
BB	4	230210	M10 x 30 FSHCS
CC	6	210012	M10 Jam Nut
DD	4	214014	M12 Regular Washer
EE	1	221230	M10 x 60MM SHCS

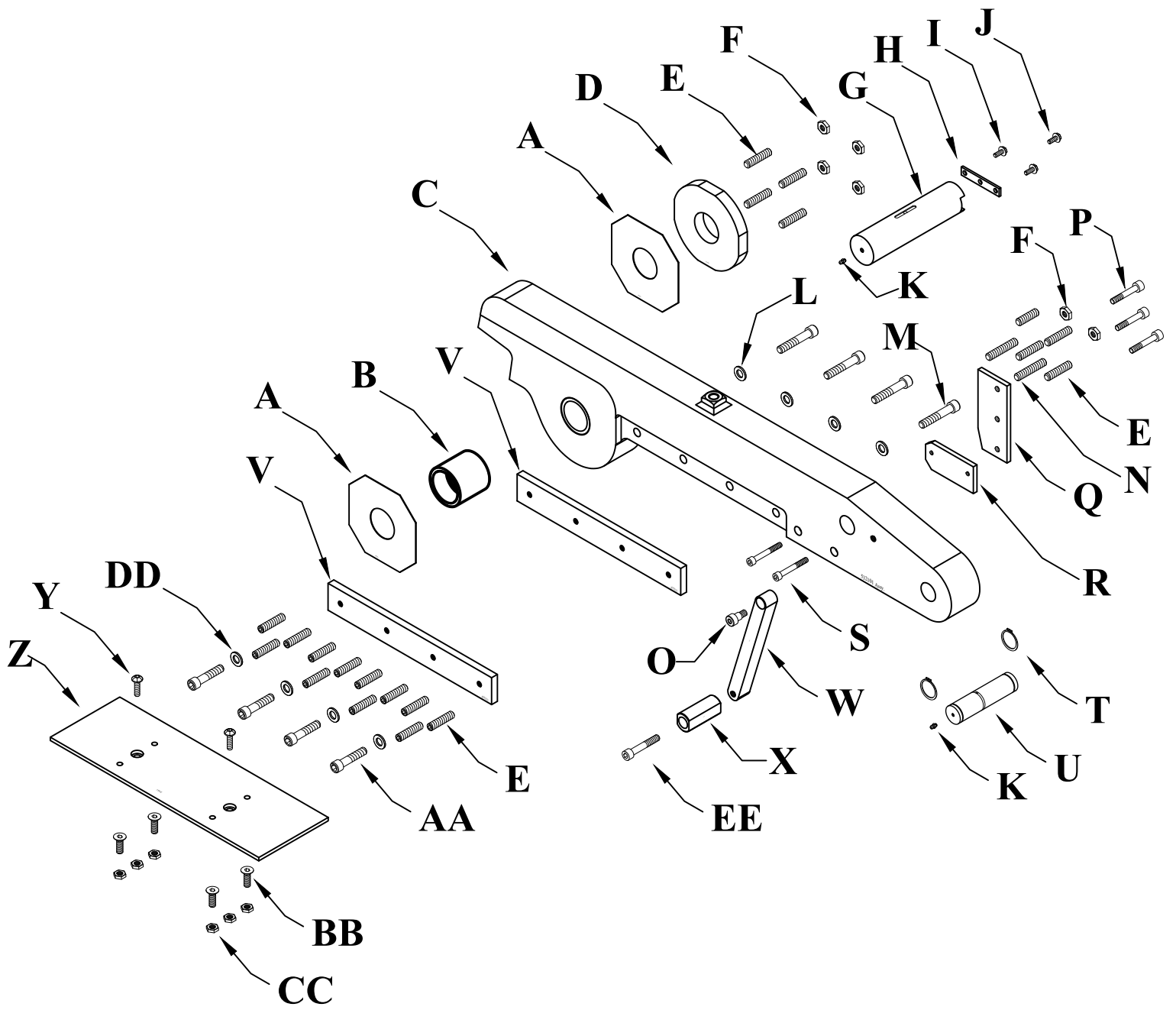

FIGURE 31

### **9.3 ELECTRIC STROKE CONTROL ASSEMBLY**

<b>ITEM</b>	<b>QTY</b>	<b>PART #</b>	<b>DESCRIPTION</b>
<b>1</b>	<b>2</b>	<b>004087</b>	<b>Pointer Rev. A</b>
<b>2</b>	<b>2</b>	<b>073420</b>	<b>M-8 x 16 DIN 912 SHCS</b>
<b>3</b>	<b>4</b>	<b>073450</b>	<b>M-4 x 16MM DIN 912 SHCS</b>
<b>4</b>	<b>2</b>	<b>080061</b>	<b>Stroke Adjustment Handle</b>
<b>5</b>	<b>2</b>	<b>530015</b>	<b>Stroke Clip</b>
<b>6</b>	<b>2</b>	<b>530017</b>	<b>Stroke Clip Back Assembly</b>
<b>7</b>	<b>1</b>	<b>530018</b>	<b>Limit Switch Box</b>
<b>8</b>	<b>2</b>	<b>534086</b>	<b>Micro Switch Side Mount</b>
<b>9</b>	<b>2</b>	<b>562110</b>	<b>Limit Switch</b>

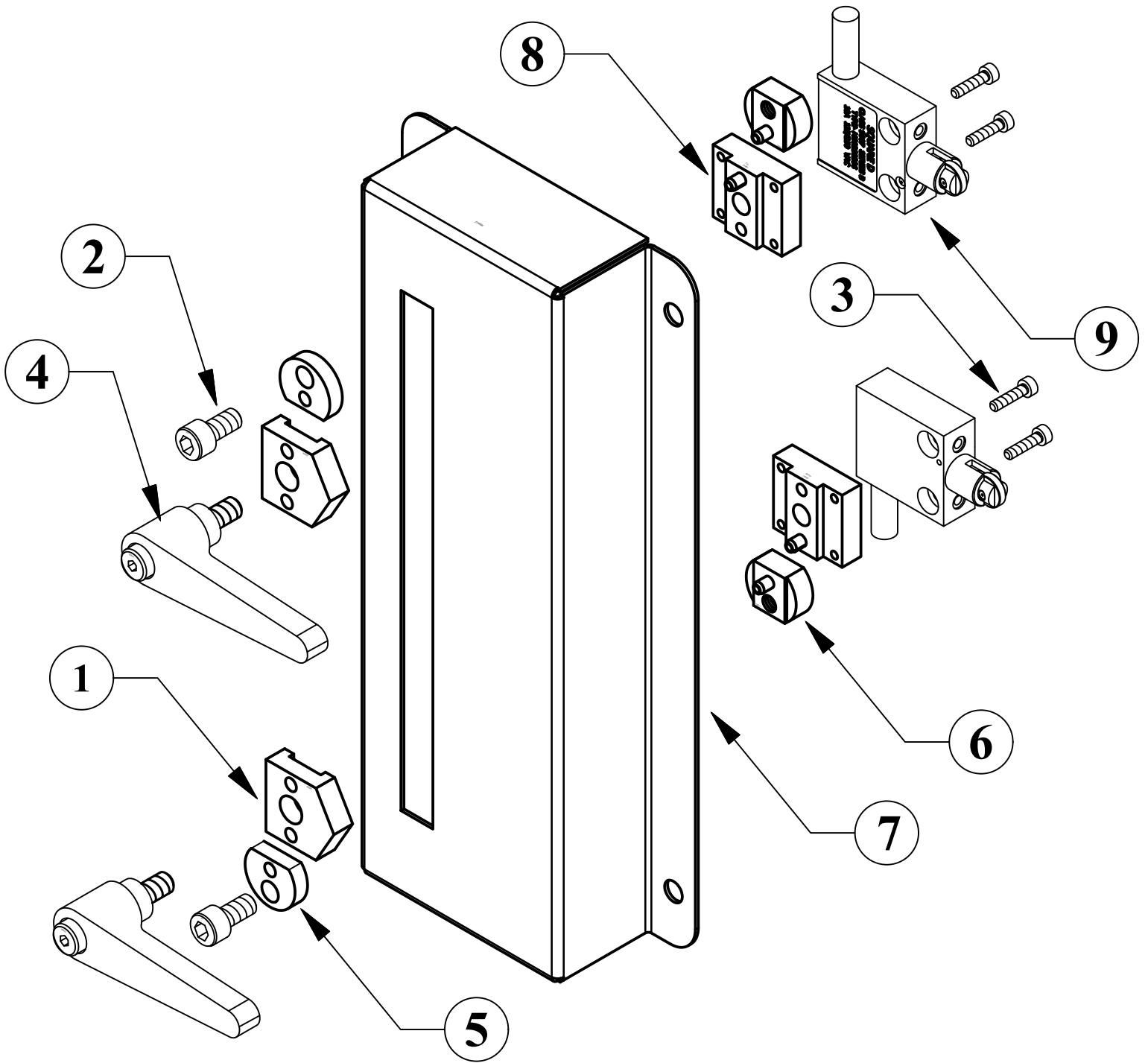
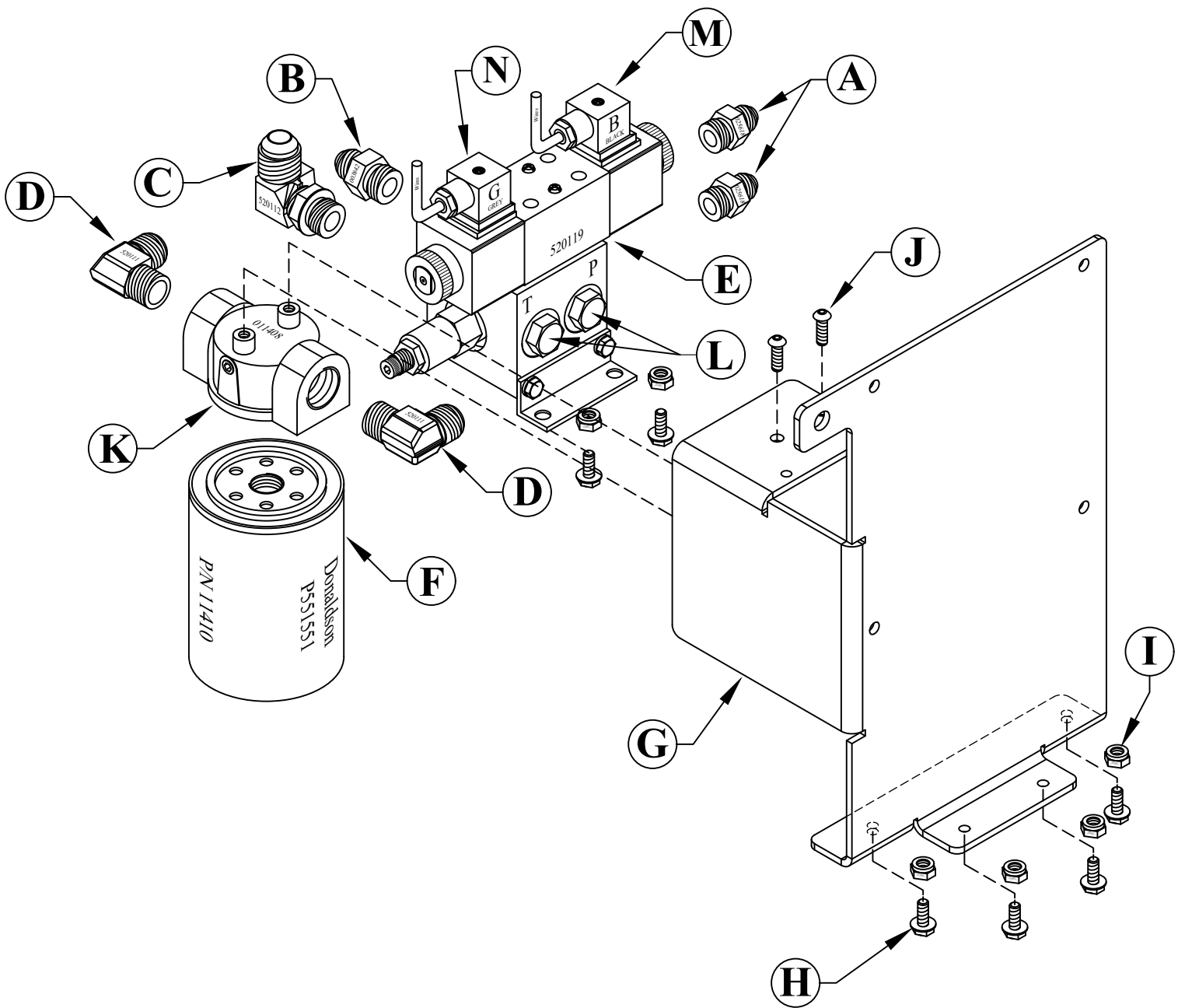

FIGURE 32

## **9.3A ELECTRIC STROKE VALVE & MANIFOLD**

<b>ITEM</b>	<b>QTY</b>	<b>PART #</b>	<b>DESCRIPTION</b>
<b>A</b>	<b>2</b>	<b>025618</b>	<b>6400-8-8 Fitting Manifold</b>
<b>B</b>	<b>1</b>	<b>003842</b>	<b>Fitting 8MJ - 10MB</b>
<b>C</b>	<b>1</b>	<b>520112</b>	<b>Fitting 12MJ - 10MB90</b>
<b>D</b>	<b>2</b>	<b>520111</b>	<b>3/4 NPT x 3/4 SAE JIC Flare 90</b>
<b>E</b>	<b>1</b>	<b>520119</b>	<b>Valve &amp; Manifold Assembly</b>
<b>E1</b>	<b>1</b>	<b>013410</b>	<b>VALVE 70 (Includes two coils)</b>
<b>E2</b>	<b>2</b>	<b>013412</b>	<b>COIL 10HR UNIT (for above)</b>
<b>F</b>	<b>1</b>	<b>011410</b>	<b>Filter</b>
<b>G</b>	<b>1</b>	<b>530029</b>	<b>Electrical Control Box Mount</b>
<b>H</b>	<b>8</b>	<b>214105</b>	<b>M-8 x 16 WLCS</b>
<b>I</b>	<b>8</b>	<b>215013</b>	<b>M-8 Greer Nut</b>
<b>J</b>	<b>2</b>	<b>120025</b>	<b>1/4" 20 x 3/4" BHSCS</b>
<b>K</b>	<b>2</b>	<b>011408</b>	<b>Filter Head</b>
<b>L</b>	<b>2</b>	<b>520113</b>	<b>SAE-10 Plug</b>
<b>M</b>	<b>1</b>	<b>006540</b>	<b>DIN Connector - Black</b>
<b>N</b>	<b>1</b>	<b>006545</b>	<b>DIN Connector - Grey</b>



**FIGURE 33**



## 9.4 HOSE & FITTING LOCATIONS

<b>A</b>	<b>1</b>	<b>003955</b>	<b>Diagnostic Nipple</b>
<b>B</b>	<b>1</b>	<b>003942</b>	<b>6MP-4FP x 90 Elbow</b>
<b>C</b>	<b>1</b>	<b>003943</b>	<b>6FP-8FJX Adaptor</b>
<b>D</b>	<b>1</b>	<b>003940</b>	<b>8MJ-8MB-8MJ Adaptor</b>
<b>E</b>	<b>1</b>	<b>003964</b>	<b>16BHS - 16MB Hose Barb</b>
<b>F</b>	<b>2</b>	<b>003845</b>	<b>8MJ - 10MB 90 Elbow</b>
<b>G</b>	<b>1</b>	<b>003860</b>	<b>14-1/2" Hose Assembly</b>
<b>H</b>	<b>2</b>	<b>016093</b>	<b>Hose Clamp 19-44 MM</b>
<b>I</b>	<b>1</b>	<b>003842</b>	<b>8MJ - 10MB Fitting</b>
<b>J</b>	<b>1</b>	<b>003870</b>	<b>41" Hose Assembly</b>
<b>K</b>	<b>1</b>	<b>520112</b>	<b>12MJ - 10MB 90 Elbow</b>
<b>L</b>	<b>1</b>	<b>003952</b>	<b>12MJ - 12MB 90 Adaptor</b>
<b>M</b>	<b>1</b>	<b>003865</b>	<b>38" Hose Assembly</b>
<b>N</b>	<b>2</b>	<b>025618</b>	<b>6400 - 8 - 8 Fitting Manifold</b>
<b>O</b>	<b>1</b>	<b>016088</b>	<b>Filler Breather Cap</b>
<b>P</b>	<b>1</b>	<b>013425</b>	<b>3/4 x 17 Return Hose</b>
<b>Q</b>	<b>2</b>	<b>520111</b>	<b>3/4 NPT x 3/4 SAE JIC Flare 90°</b>
<b>R</b>	<b>1</b>	<b>003861</b>	<b>12G112FJX12FJX26" Hose</b>
<b>S</b>	<b>1</b>	<b>003857</b>	<b>16 - 12 - NWO Elbow</b>
<b>T</b>	<b>1</b>	<b>530055</b>	<b>1 x 14.50 Suction Hose</b>
<b>U</b>	<b>1</b>	<b>350014</b>	<b>1/2" Magnetic Plug</b>

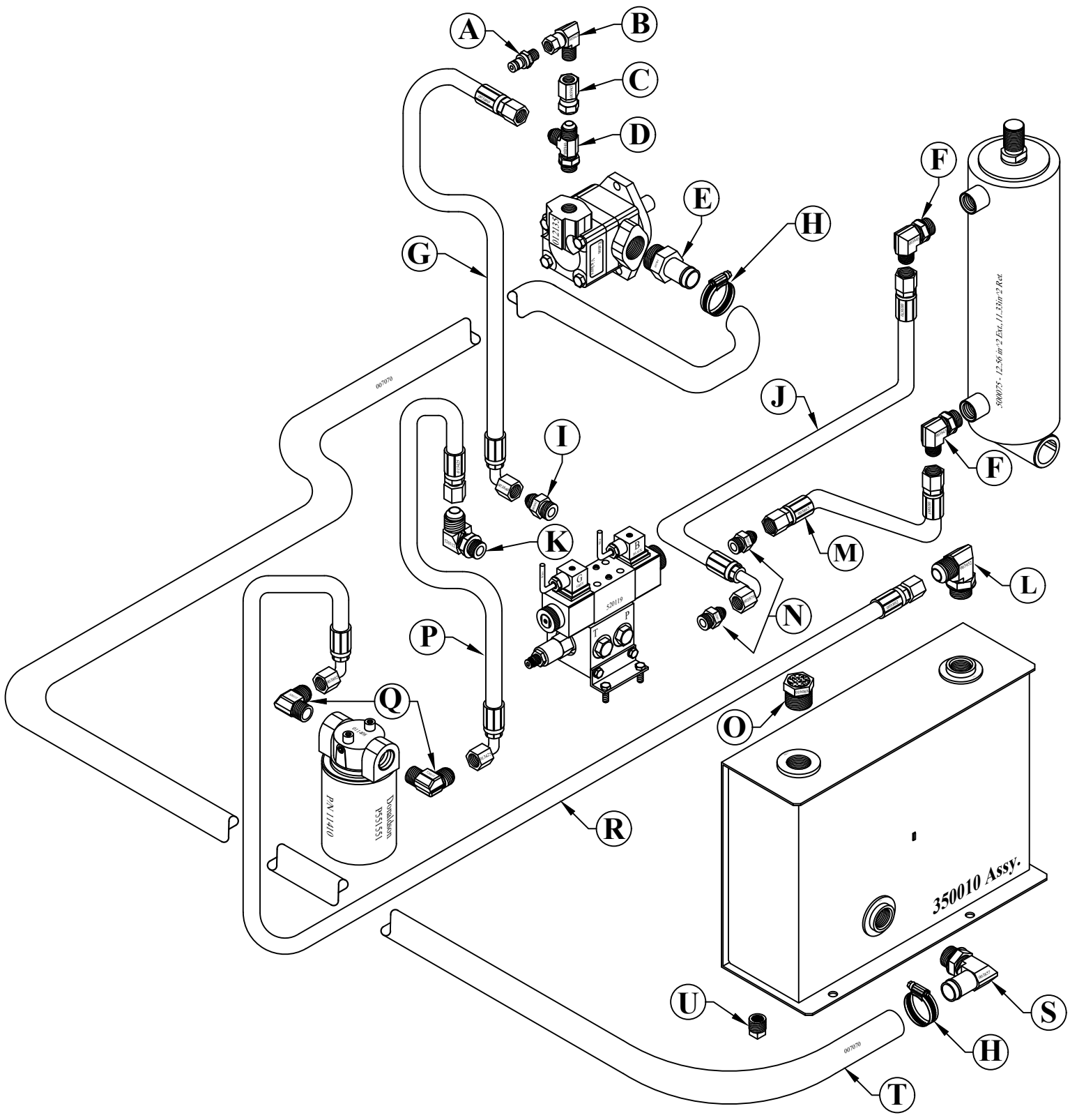
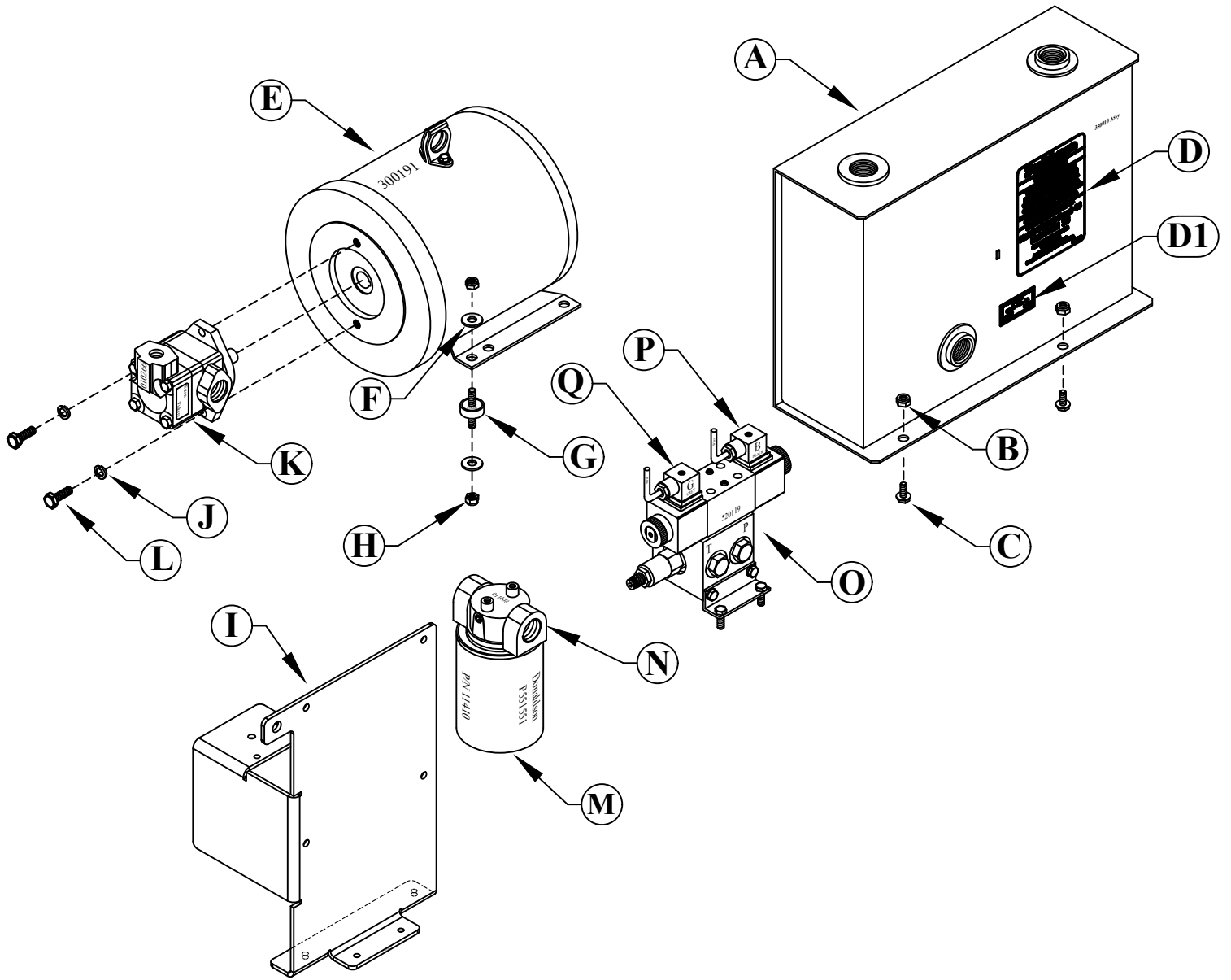

FIGURE 34

## 9.4A POWER UNIT

<b>ITEM</b>	<b>QTY</b>	<b>PART #</b>	<b>DESCRIPTION</b>
<b>A</b>	<b>1</b>	<b>350010</b>	<b>Reservoir</b>
<b>B</b>	<b>2</b>	<b>215013</b>	<b>M-8 Greer Nylon Lock Nut</b>
<b>C</b>	<b>2</b>	<b>224105</b>	<b>M-8 x 16MM WLCS</b>
<b>D</b>	<b>1</b>	<b>003175</b>	<b>Caution - Contamination</b>
<b>D1</b>	<b>1</b>	<b>019102</b>	<b>Decal - Reservoir Capacity</b>
<b>E</b>	<b>1</b>	<b>Varies.</b>	<b>Motor</b>
		<b>391003</b>	<b>208 Volt Motor Assembly</b>
		<b>391004</b>	<b>230 Volt Motor Assembly</b>
		<b>391007</b>	<b>460 Volt Motor Assembly</b>
		<b>311005</b>	<b>220 Volt 1PH Motor Assembly</b>
<b>F</b>	<b>8</b>	<b>114011</b>	<b>5/16 Flat Washer</b>
<b>G</b>	<b>4</b>	<b>158201</b>	<b>5/16 x 18 Grommet</b>
<b>H</b>	<b>8</b>	<b>115011</b>	<b>5/16 Nylon Lock Nut</b>
<b>I</b>	<b>1</b>	<b>530029</b>	<b>Electrical Control Box Mount</b>
<b>J</b>	<b>2</b>	<b>563441</b>	<b>3/8 Lock Washer</b>
<b>K</b>	<b>1</b>	<b>010266</b>	<b>Hydraulic Pump</b>
<b>L</b>	<b>2</b>	<b>101210</b>	<b>3/8 x 16 x 1 HHCS</b>
<b>M</b>	<b>1</b>	<b>011410</b>	<b>Spin On Filter</b>
<b>N</b>	<b>1</b>	<b>011408</b>	<b>Filter Head</b>
<b>O</b>	<b>1</b>	<b>520119</b>	<b>Valve &amp; Manifold Assembly</b>
<b>O*</b>	<b>1</b>	<b>013410</b>	<b>Valve 70 (Valve ONLY)</b>
<b>P</b>	<b>1</b>	<b>006540</b>	<b>DIN Connector - Black</b>
<b>Q</b>	<b>1</b>	<b>006545</b>	<b>DIN Connector - Grey</b>



**FIGURE 35**

## 9.6 ELECTRICAL CONTROLS

ITEM	QTY	PART #	DESCRIPTION
1	1	004521	Legend Plate Holder
2*	1	011200	Kraus & Naimer Cam Switch
3	1	011210	Legend Punch/Start/Shear K&N
4	1	011500	Legend Stop
5	1	011509	Legend Start
6	1	011854	Moeller Disconnect Switch (Black) - <u>Old Style - S/N 5588 &amp; Prior</u>
6A	1	011895	Moeller Disconnect Actuator w/o Stem
6B	1	011875	Stem for #011895 (for above - not shown)
6.1	1	520201	Eaton Disconnect Switch (White) - <u>New Style - S/N 5589 &amp; Up</u>
6.1A	1	520202	Eaton Selector Knob Red/Yellow w/o Stem
6.1B	1	520203	Disconnect Shaft Ext. 150MM (for above)
7	1	011862	E-Stop Operator Packaged W/ 11872
8	1	011867	Contact M22-K01
9	1	011879	Start Button
10	1	520115	50 Ton Electrical Panel Rev. C
11	1	011975	DILM 25-10 Contact W/ 120V Coil
12	1	011861	Transformer-250VA
13	1	011998	ZB32-10 6-10 Amp Overload (230V)
13A	1	011991	ZB32-6 4-6 Amp Overload (460V)
13B	1	011999	ZB32-32 16-24 Amp Overload (220V) 1PH
14	1	011920	Primary Fuse 1 Amp
15	1	011835	Secondary Fuse
16	3	563441	3/4" Liq. Type Cord Connector
17	2	000202	1/2" Liq. Type Cord Connector
18	2	562502	1/2 Conduit Locknut (not shown)
19	1	562453	Foot Switch Assembly
20**	1	562451	Microswitch For SSC Foot Pedal (not shown)
20A**	1	562452	Microswitch For Linemaster Foot Pedal (not shown)
21	1	520215	Complete Control Box (Less Overload) Includes 562453 - Foot Switch Assembly

\* S/N 5100EC0422 and up - Replacement Cam Switch - ITEM 3 is also required if replacing old style switch.

\*\* Before ordering a microswitch - Inspect foot pedal to determine if it's a Linemaster or SSC.

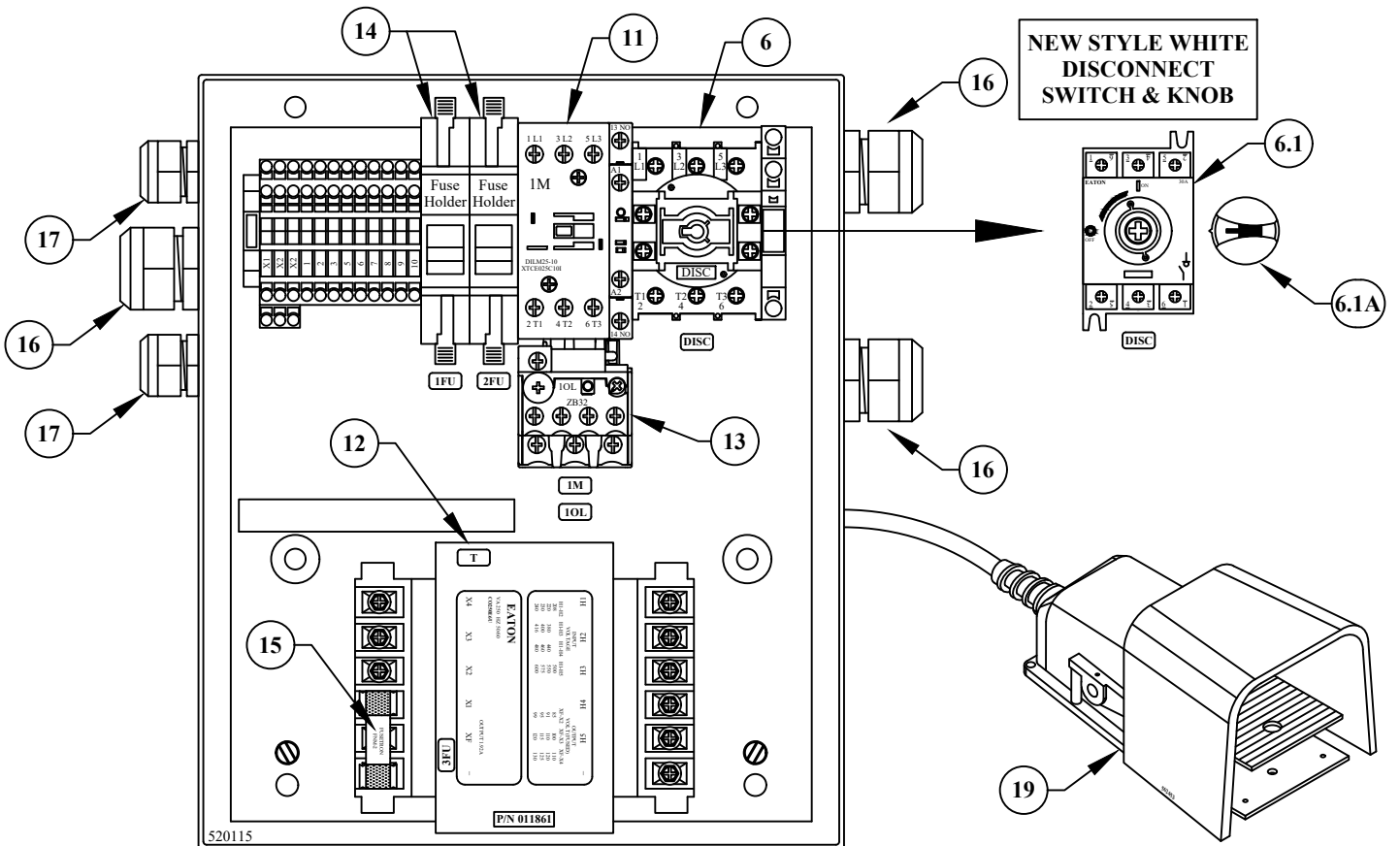
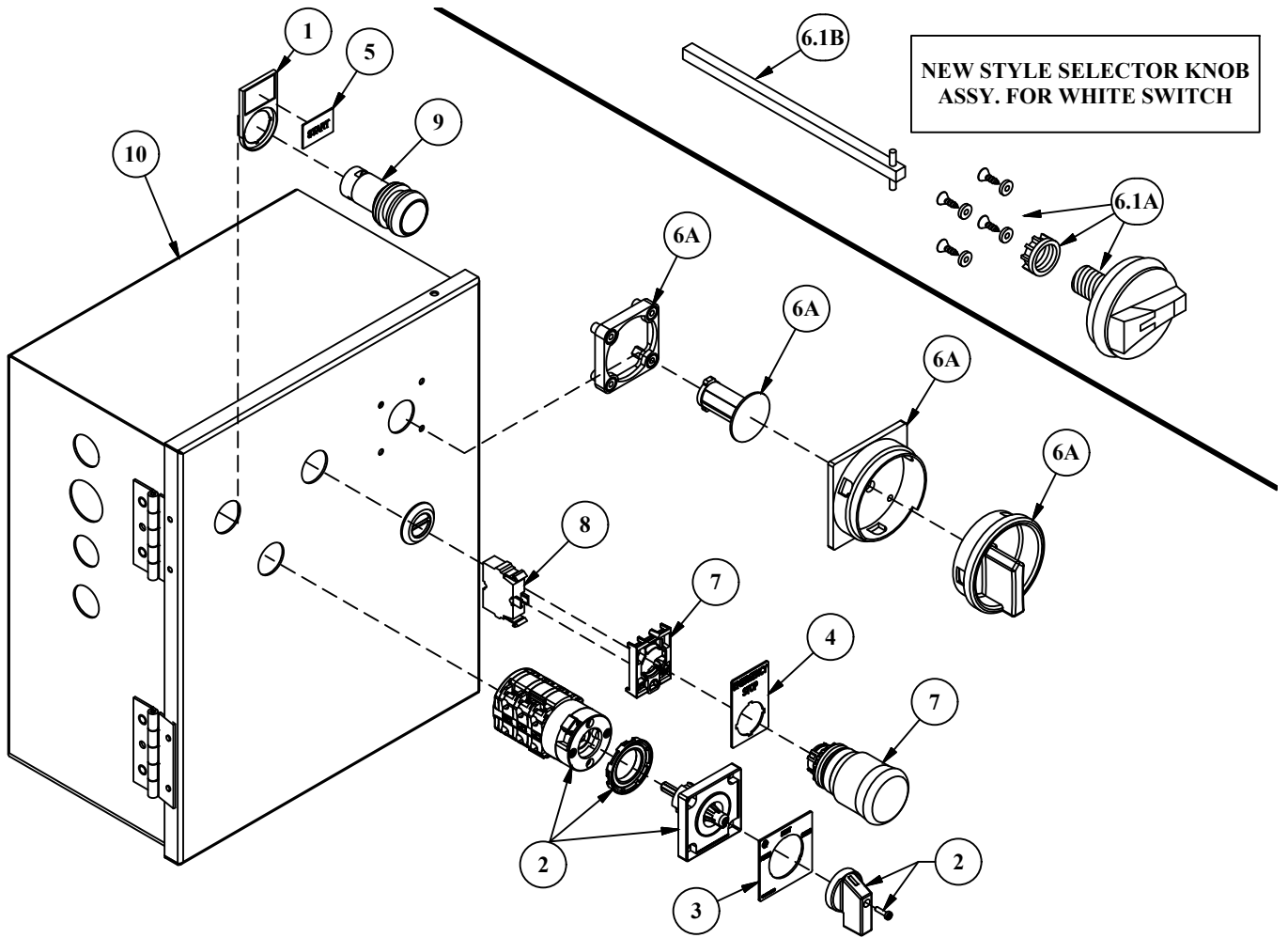

**FIGURE 36**

## 9.6 4 X 4 ANGLE SHEAR

<b>ITEM</b>	<b>QTY</b>	<b>PART #</b>	<b>DESCRIPTION</b>
<b>A</b>	<b>1</b>	<b>343430</b>	<b>Front Side Plate</b>
<b>B</b>	<b>1</b>	<b>343431</b>	<b>Rear Side Plate</b>
<b>C</b>	<b>1</b>	<b>343417</b>	<b>Top Angle Blade 4 x 4</b>
<b>D</b>	<b>1</b>	<b>343432</b>	<b>Blade &amp; Spring Cap</b>
<b>E</b>	<b>1</b>	<b>430281</b>	<b>Rocker Cap Assembly A.S. (Includes E1 &amp; E2)</b>
<b>E1</b>	<b>1</b>	<b>430381</b>	<b>Pressure Block A.S.</b>
<b>E2</b>	<b>1</b>	<b>430241</b>	<b>Rocker Plate</b>
<b>F</b>	<b>1</b>	<b>221227</b>	<b>M-10 x 55 SHCS</b>
<b>G</b>	<b>2</b>	<b>343420</b>	<b>Wear Strip</b>
<b>H</b>	<b>2</b>	<b>026746</b>	<b>Retainer, Wear Strip</b>
<b>I</b>	<b>2</b>	<b>201110</b>	<b>M-6 x 12 HHCS</b>
<b>J</b>	<b>2</b>	<b>343002</b>	<b>1/4 x 3/4 Dowel Pin</b>
<b>K</b>	<b>1</b>	<b>343202</b>	<b>4" A.S. Front Guard Assembly</b>
<b>L</b>	<b>4</b>	<b>243101</b>	<b>M-6 x 13.5 OAL Gold Zerk</b>
<b>M</b>	<b>8</b>	<b>204222</b>	<b>M-10 x 55 HHCS</b>
<b>N</b>	<b>18</b>	<b>214012</b>	<b>M-10 Regular Washer</b>
<b>O</b>	<b>8</b>	<b>203212</b>	<b>M-10 x 30 HHCS</b>
<b>P</b>	<b>4</b>	<b>343412</b>	<b>Lower Blade 4 x 4 A.S.</b>
<b>Q</b>	<b>2</b>	<b>016127</b>	<b>3/4 x 4 Die Spring</b>
<b>R</b>	<b>1</b>	<b>343232</b>	<b>4" A.S. Rear Guard</b>
<b>S</b>	<b>4</b>	<b>343423</b>	<b>Shim Lower Blade</b>
<b>T</b>	<b>2</b>	<b>201210</b>	<b>M-10 x 20 HHCS</b>
<b>U</b>	<b>1</b>	<b>215012</b>	<b>M-10 Greer Nut</b>
<b>V</b>	<b>1</b>	<b>330251</b>	<b>Knob A.S. Guard</b>
<b>W</b>	<b>1</b>	<b>220014</b>	<b>M-6 x 10 BHCS</b>
<b>X</b>		<b>343425</b>	<b>Complete 4 x 4 Angle Shear</b>

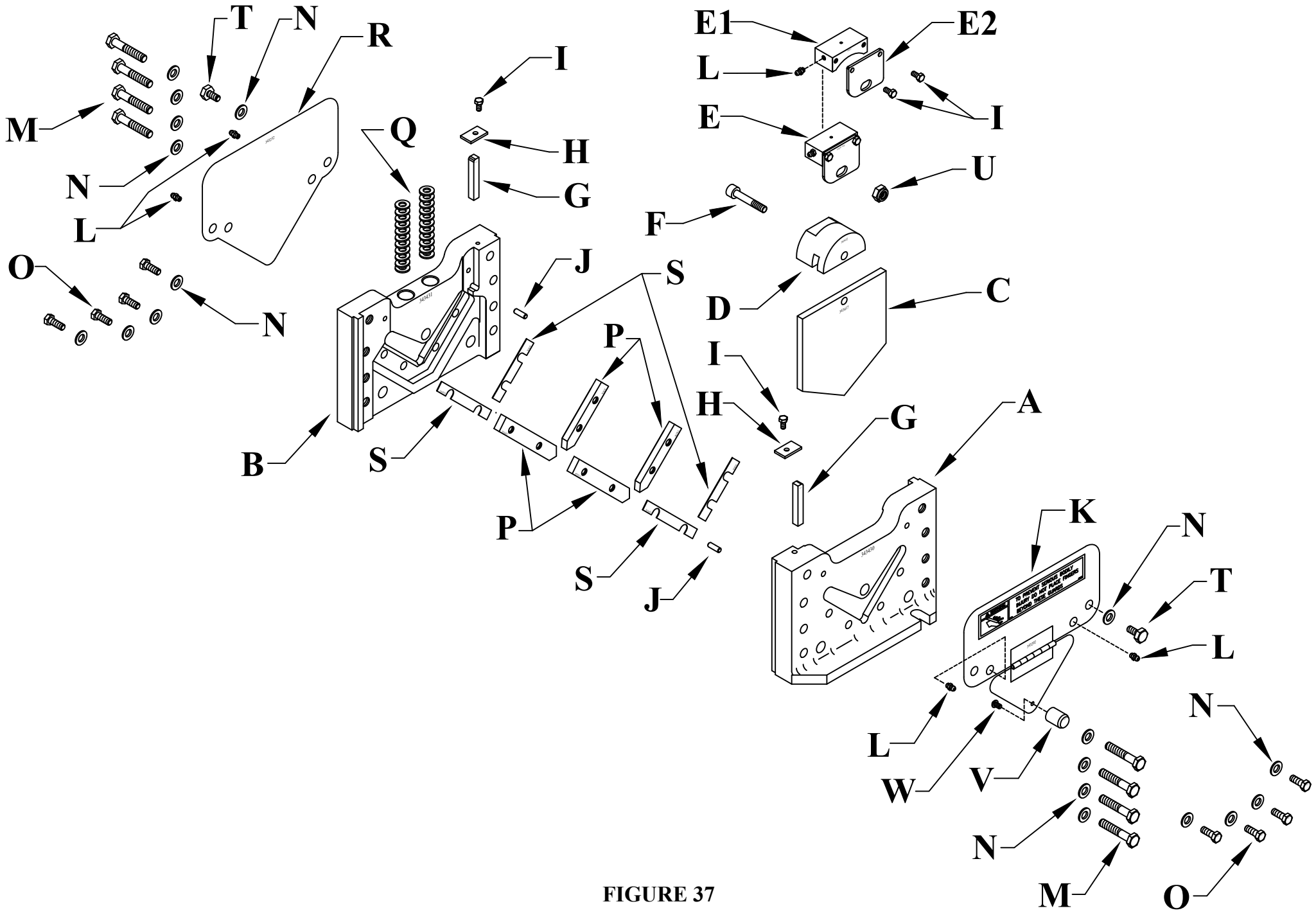

FIGURE 37



## 9.7 NOTCHER ASSEMBLY

<b>ITEM</b>	<b>QTY</b>	<b>PART #</b>	<b>DESCRIPTION</b>
<b>A</b>	<b>1</b>	<b>341060</b>	<b>5014 Upper Notcher Blade</b>
<b>B</b>	<b>3</b>	<b>341078</b>	<b>Lower Notcher Blade</b>
<b>C</b>	<b>1</b>	<b>341235</b>	<b>Notcher Blade Holder</b>
<b>D</b>	<b>1</b>	<b>341167</b>	<b>50 Ton Notcher Table</b>
<b>E</b>	<b>2</b>	<b>221314</b>	<b>M-12 x 35 SHCS</b>
<b>F</b>	<b>4</b>	<b>221420</b>	<b>M-16 x 50 SHCS</b>
<b>G</b>	<b>4</b>	<b>214017</b>	<b>1" Bokers Hard Washer</b>
<b>H</b>	<b>4</b>	<b>221322</b>	<b>M-12 x 60 SHCS</b>
<b>I</b>	<b>2</b>	<b>221326</b>	<b>M-12 x 65 SHCS</b>
<b>J</b>	<b>4</b>	<b>230207</b>	<b>M-10 x 20 FSHCS</b>

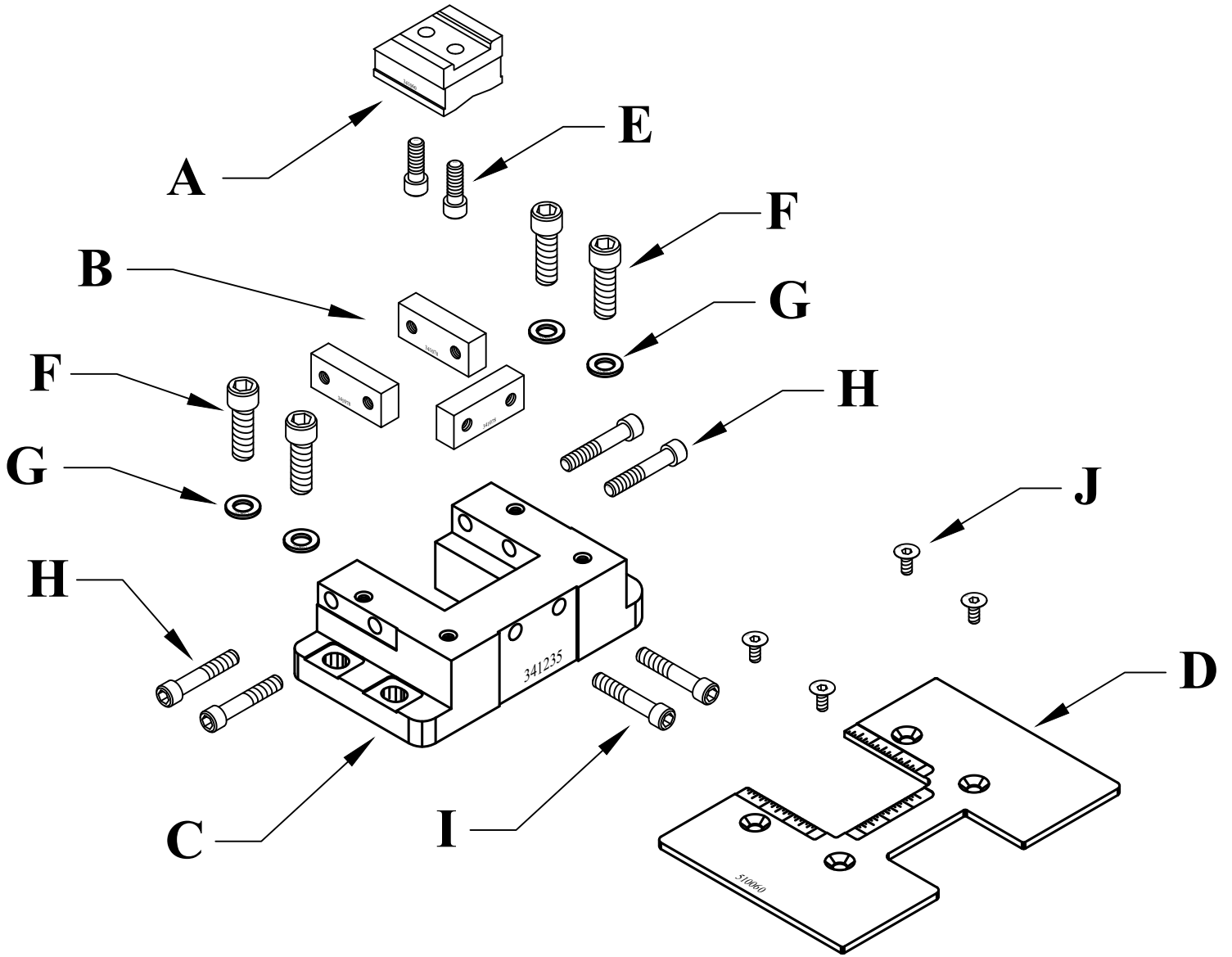
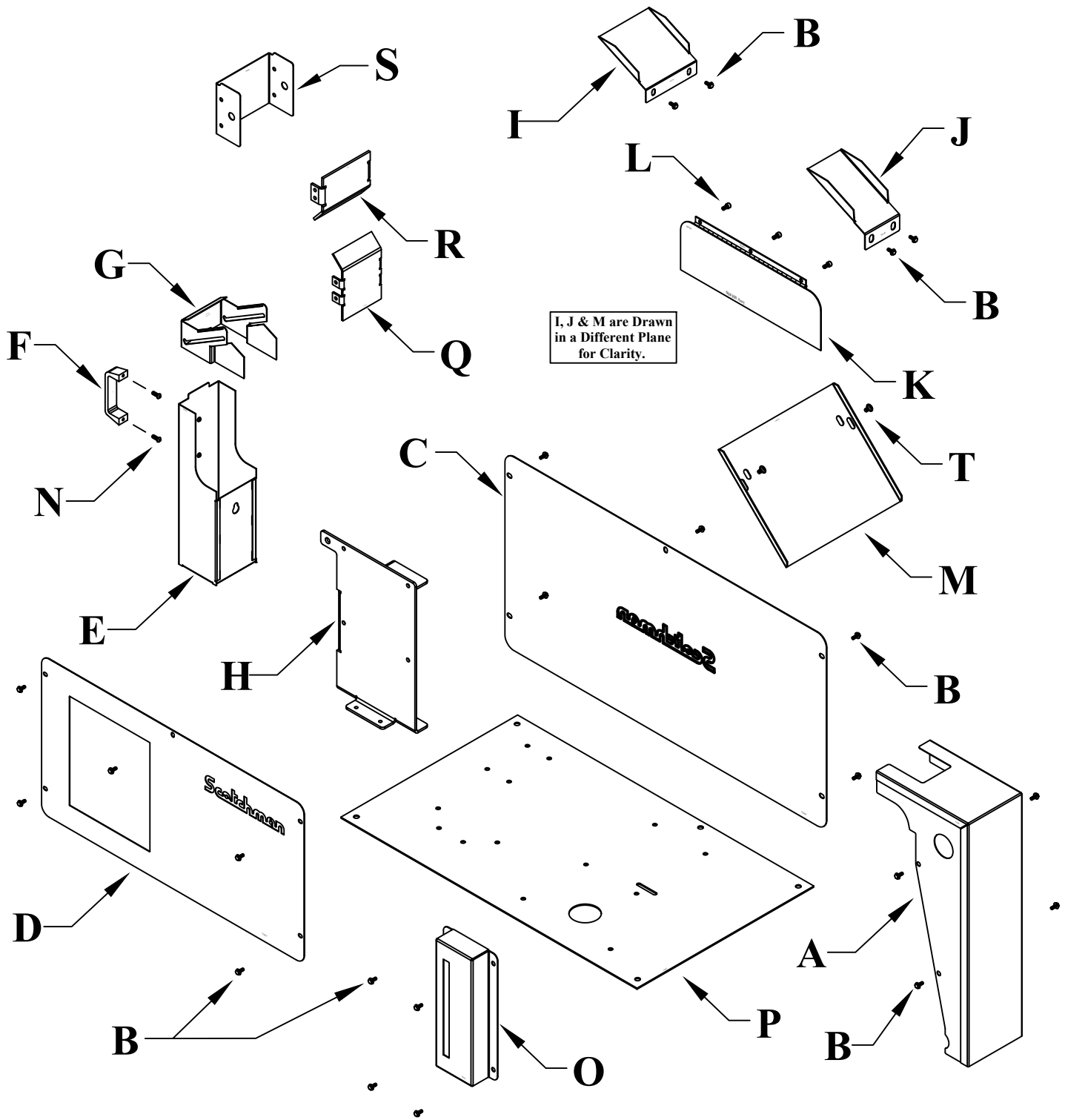

FIGURE 38

## 9.8 SHEET METAL

<b>ITEM</b>	<b>PART #</b>	<b>DESCRIPTION</b>
<b>A</b>	<b>532003</b>	<b>50T Cylinder Shroud</b>
<b>B</b>	<b>224105</b>	<b>M8 X 16MM WLCS</b>
<b>C</b>	<b>532068</b>	<b>50 Ton Rear Shroud</b>
<b>D</b>	<b>532013</b>	<b>50T Front Shroud</b>
<b>E</b>	<b>530062</b>	<b>50T Notcher Bucket</b>
<b>F</b>	<b>046018</b>	<b>Handle</b>
<b>G</b>	<b>530041</b>	<b>50T Notcher Guard</b>
<b>H</b>	<b>530029</b>	<b>Electrical Control Box Mount</b>
<b>I</b>	<b>341136</b>	<b>4" A.S. Slug Chute</b>
<b>J</b>	<b>341140</b>	<b>Pipe Notcher Chute</b>
<b>K</b>	<b>004300</b>	<b>Bar Shear Door Assembly</b>
<b>L</b>	<b>221005</b>	<b>M6 X 12MM SHCS</b>
<b>M</b>	<b>530022</b>	<b>50T Shear Ramp</b>
<b>N</b>	<b>220014</b>	<b>M6 x 10 BHCS</b>
<b>O</b>	<b>530018</b>	<b>Limit Switch Box</b>
<b>P</b>	<b>530027</b>	<b>50T Skid</b>
<b>Q</b>	<b>533151</b>	<b>50T Notcher Slug Chute</b>
<b>R</b>	<b>530039</b>	<b>50T Punch Slug Ramp</b>
<b>S</b>	<b>530012</b>	<b>Punch Guard Raw</b>
<b>T</b>	<b>220060</b>	<b>M8 X 16MM Flanged BHCS</b>



**FIGURE 39**

## **9.9 CYLINDER**

<b>ITEM</b>	<b>PART #</b>	<b>DESCRIPTION</b>
<b>A</b>	<b>155030</b>	<b>Snap Ring</b>
<b>B</b>	<b>500096</b>	<b>Cylinder Clevis Pin</b>
<b>C</b>	<b>111020</b>	<b>Locking Nut</b>
<b>D</b>	<b>500097</b>	<b>Cylinder Clevis</b>
<b>E</b>	<b>500175</b>	<b>Cylinder (Includes C &amp; D)</b>
<b>E1</b>	<b>350006</b>	<b>Cylinder Seal Kit</b>
<b>F</b>	<b>530076</b>	<b>Cylinder Anchor Pin</b>

**NOTE: Numbers are for reference only.**

**1-14UNS-2A THREAD**

APPLY PERMANENT (RED) LOCKING ADHESIVE TO (13) CANNED WIPER

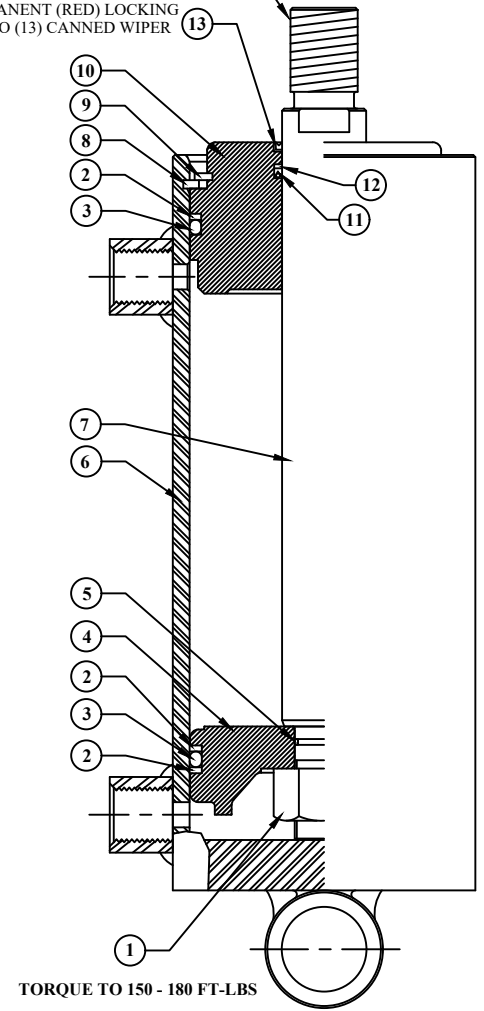
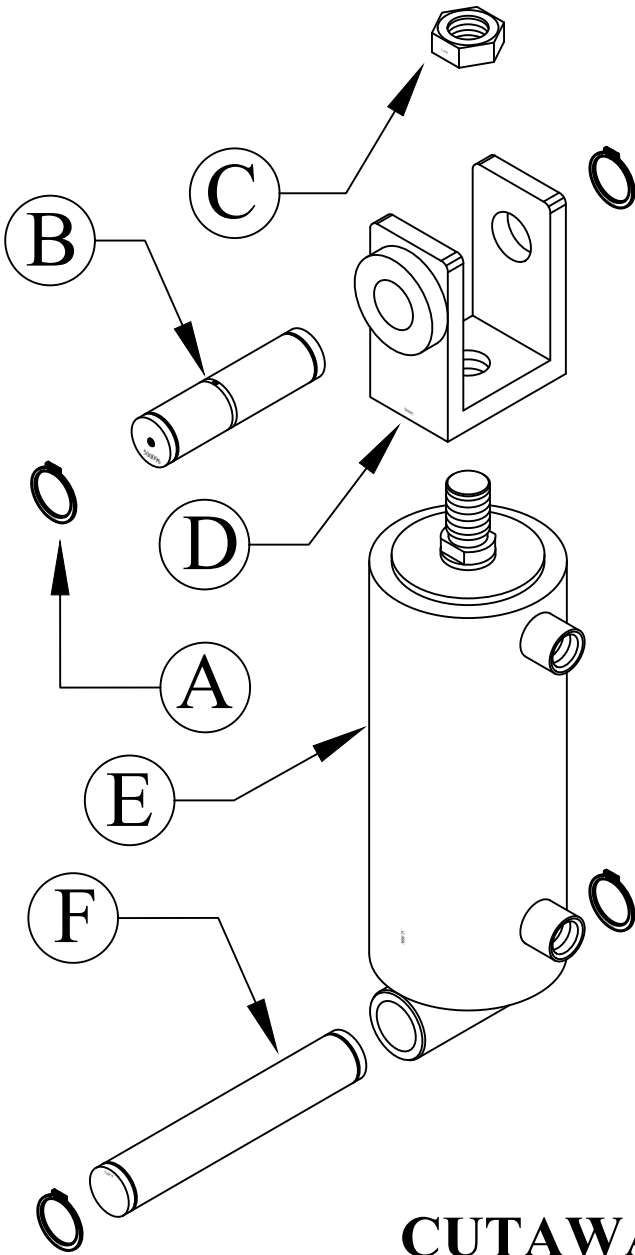

## CUTAWAY VIEW DETAIL

**TOP**

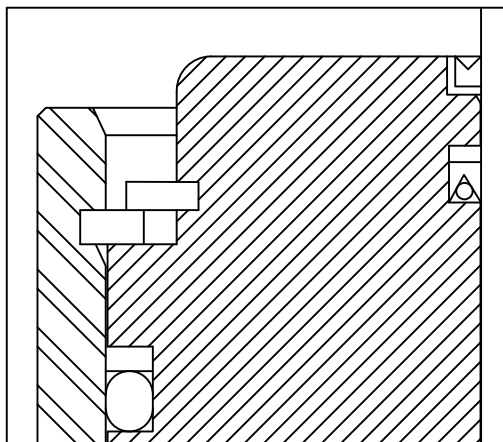

**BOTTOM**

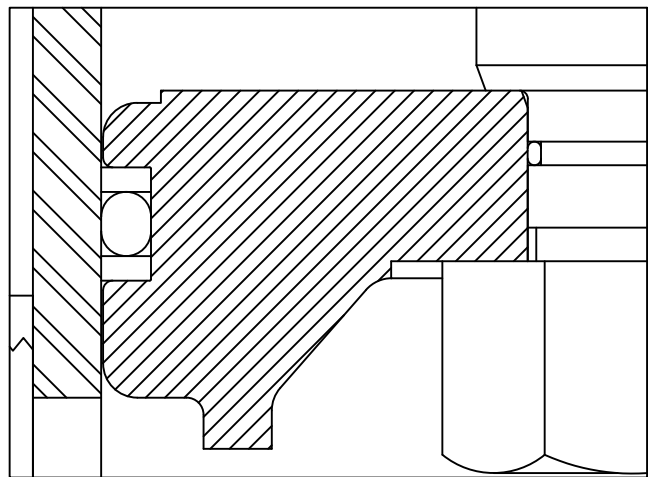

**FIGURE 40**

## 9.10 HOLD DOWN ASSEMBLY

<b>ITEM</b>	<b>QTY</b>	<b>PART#</b>	<b>DESCRIPTION</b>
<b>A</b>	<b>1</b>	<b>500087</b>	<b>Hold Down W/Guards</b>
<b>B</b>	<b>4</b>	<b>073206</b>	<b>M-6 Hex Nut</b>
<b>C</b>	<b>2</b>	<b>500099</b>	<b>50 Ton Lexan Hold Down Guard</b>
<b>D</b>	<b>2</b>	<b>013180</b>	<b>Hinge</b>
<b>E</b>	<b>4</b>	<b>213007</b>	<b>M-6 Large Washer</b>
<b>F</b>	<b>8</b>	<b>201110</b>	<b>M-6 x 12 HHCS</b>
<b>G</b>	<b>2</b>	<b>500090</b>	<b>Mount Hold Down</b>
<b>H</b>	<b>1</b>	<b>001551</b>	<b>Return Spring</b>
<b>I</b>	<b>4</b>	<b>221327</b>	<b>M-12 x 70MM SHCS</b>
<b>J</b>	<b>1</b>	<b>500098</b>	<b>Bearing Hold Down</b>
<b>K</b>	<b>1</b>	<b>400720</b>	<b>Handle Assembly</b>

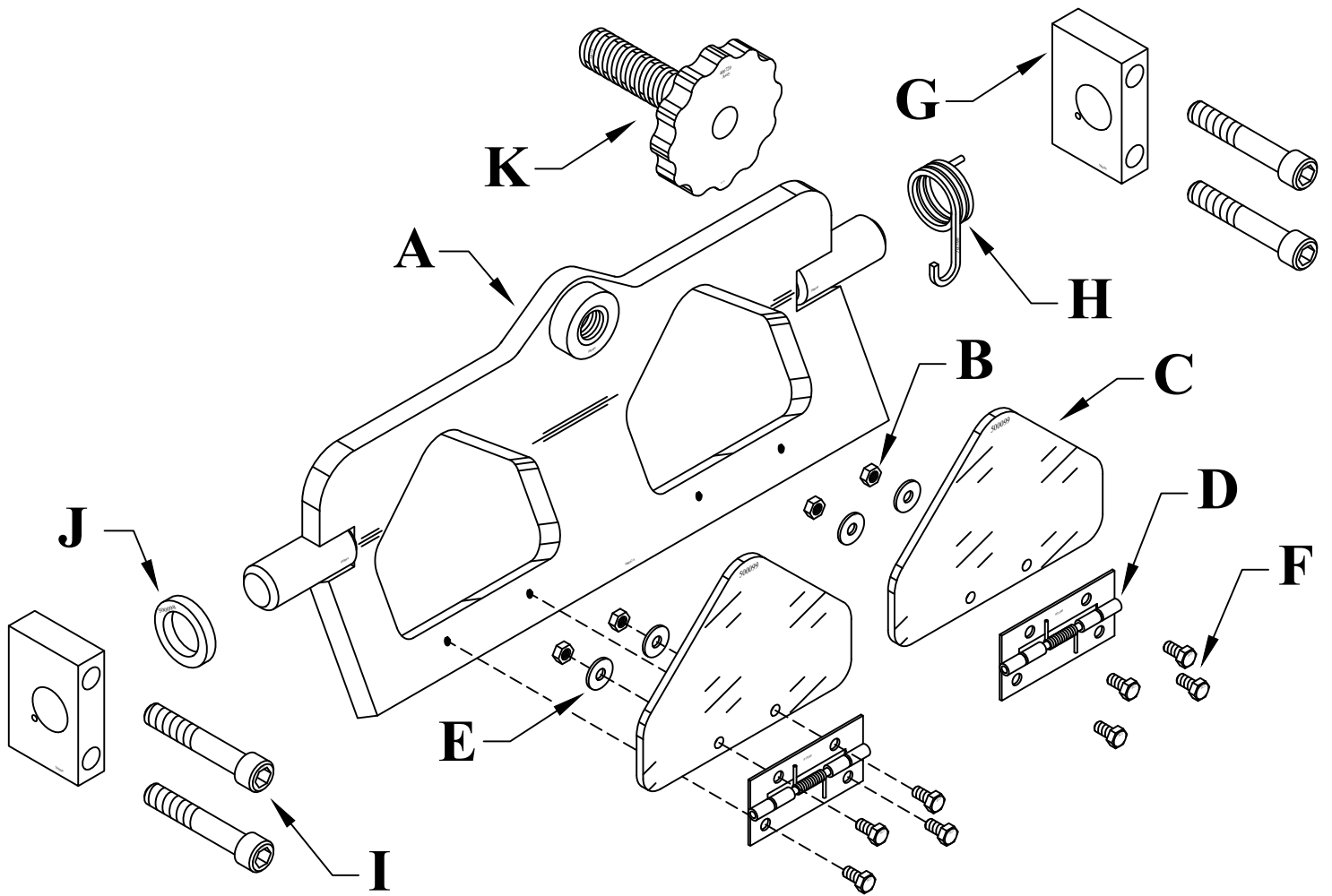

**FIGURE 41**



## 9.11 OPTIONAL JOG CONTROL ASSEMBLY

ITEM	PART #	DESCRIPTION
A	004521	Legend Plate Holder
B	004526	Run Jog Legend
C	004530	Opt. Jog Box - Painted
D	011874	Contact Element
E	011877	Selector Switch
F	011886	Jog Button Assembly
G	073206	M-6 DIN 934 Hex Nut
H	073450	M-4 x 16MM DIN 912 SHCS
I	145005	Small Blue Wire Nut
J	220020	M-6 x 16 BHCS
K	224105	M-8 x 18 DIN BN73 WLCS
L	562501	M-16 Liq. Type Connector
M	563501	12-10 Ins. Loop End

**\*\*\*The jog control is an option and is not installed as standard equipment.**

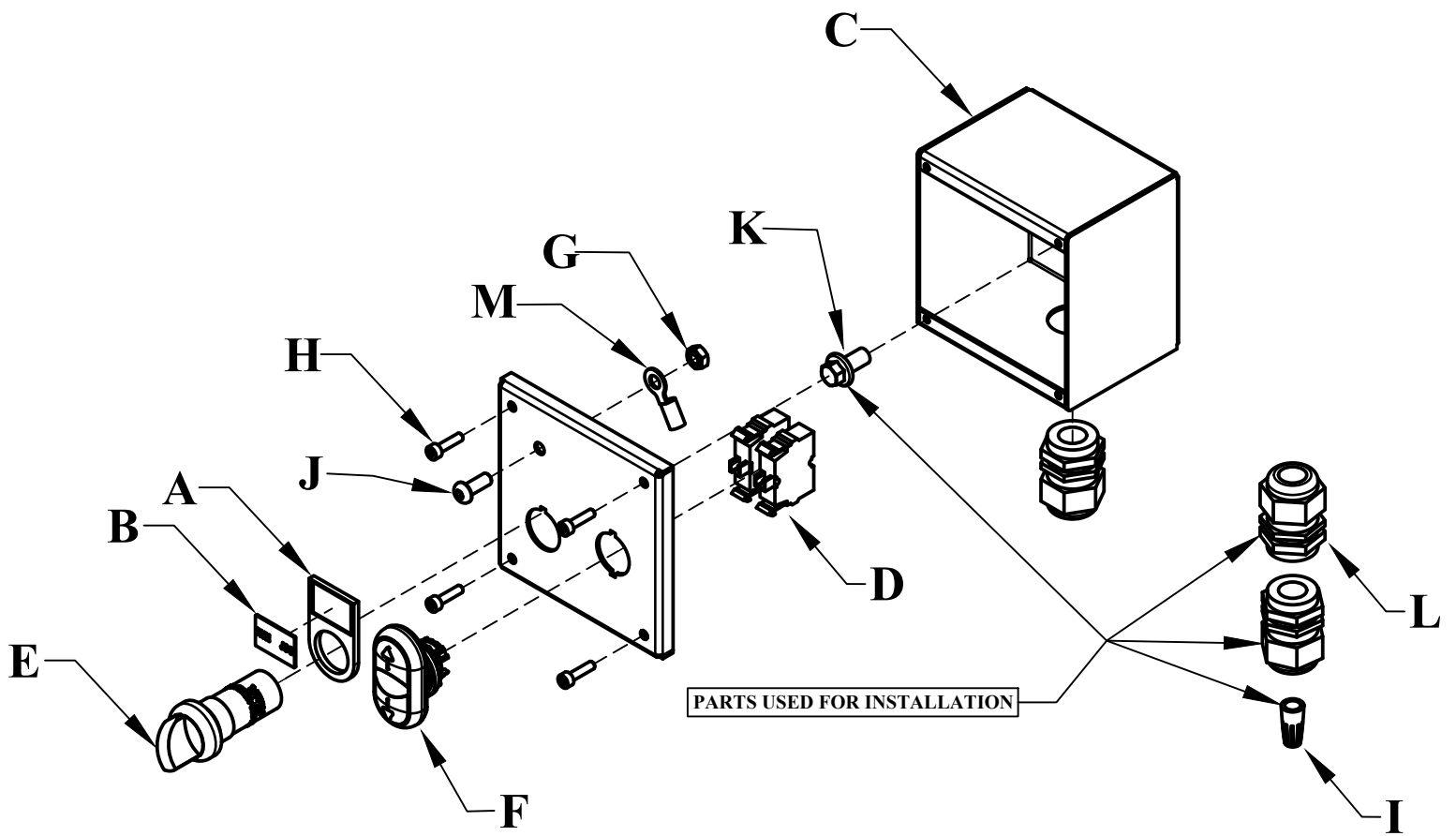

FIGURE 42

# 10.0 ELECTRICAL SCHEMATICS

## Three Phase

**NOTE:** Incoming Power is wired in easier by unhooking Disconnect Switch from rail. At the bottom of switch there is a white plastic lock. Wedge a straight screw-driver between the lock and switch to remove. Connect wires and snap Disconnect Switch back into place.

PN 520115 RATING TABLE					
LINE VOLTAGE (3PH)	208	230	380	460	575
MAX. HP	3	3	3	3	3
MOTOR FLA	9.8	8.4	4.7	4.2	3.6
OVERLOAD	ZB32-10	ZB32-10	ZB32-6	ZB32-6	ZB32-6

INCOMING SUPPLY (BY CUSTOMER) PROVIDE MAXIMUM UPSTREAM PROTECTION PER N.E.C. CODE 430-52 AND TABLE 430-152.

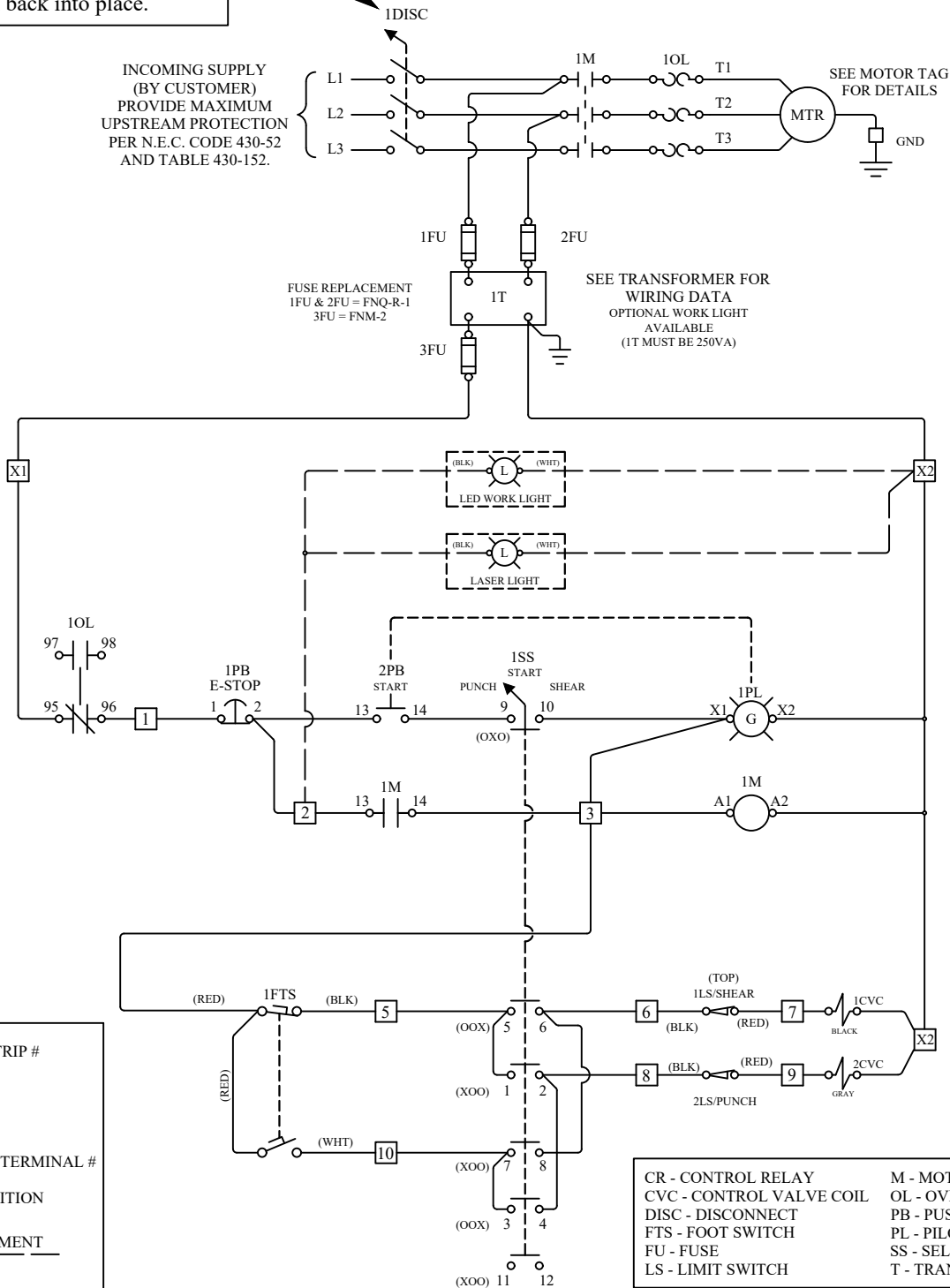

**1** - TERMINAL STRIP #  
**(2)** - WIRE #  
 BLK - WIRE COLOR  
**3** - COMPONENT TERMINAL #  
 (XO) - NORMAL POSITION  
 -----  
 OPTIONAL EQUIPMENT  
 -----  
 COMPONENT

CR - CONTROL RELAY  
 CVC - CONTROL VALVE COIL  
 DISC - DISCONNECT  
 FTS - FOOT SWITCH  
 FU - FUSE  
 LS - LIMIT SWITCH  
 M - MOTOR START RELAY  
 OL - OVERLOAD (THERMAL)  
 PB - PUSH BUTTON  
 PL - PILOT LIGHT  
 SS - SELECTOR SWITCH  
 T - TRANSFORMER

**FIGURE 43**

# Single Phase

**NOTE:** Incoming Power is wired in easier by unhooking Disconnect Switch from rail. At the bottom of switch there is a white plastic lock. Wedge a straight screw-driver between the lock and switch to remove. Connect wires and snap Disconnect Switch back into place.

PN 520115 RATING TABLE	
LINE VOLTAGE (1PH)	230
MAX. HP	5
MOTOR FLA	21
OVERLOAD	ZB32-24

INCOMING SUPPLY (BY CUSTOMER) PROVIDE MAXIMUM UPSTREAM PROTECTION PER N.E.C. CODE 430-52 AND TABLE 430-152.

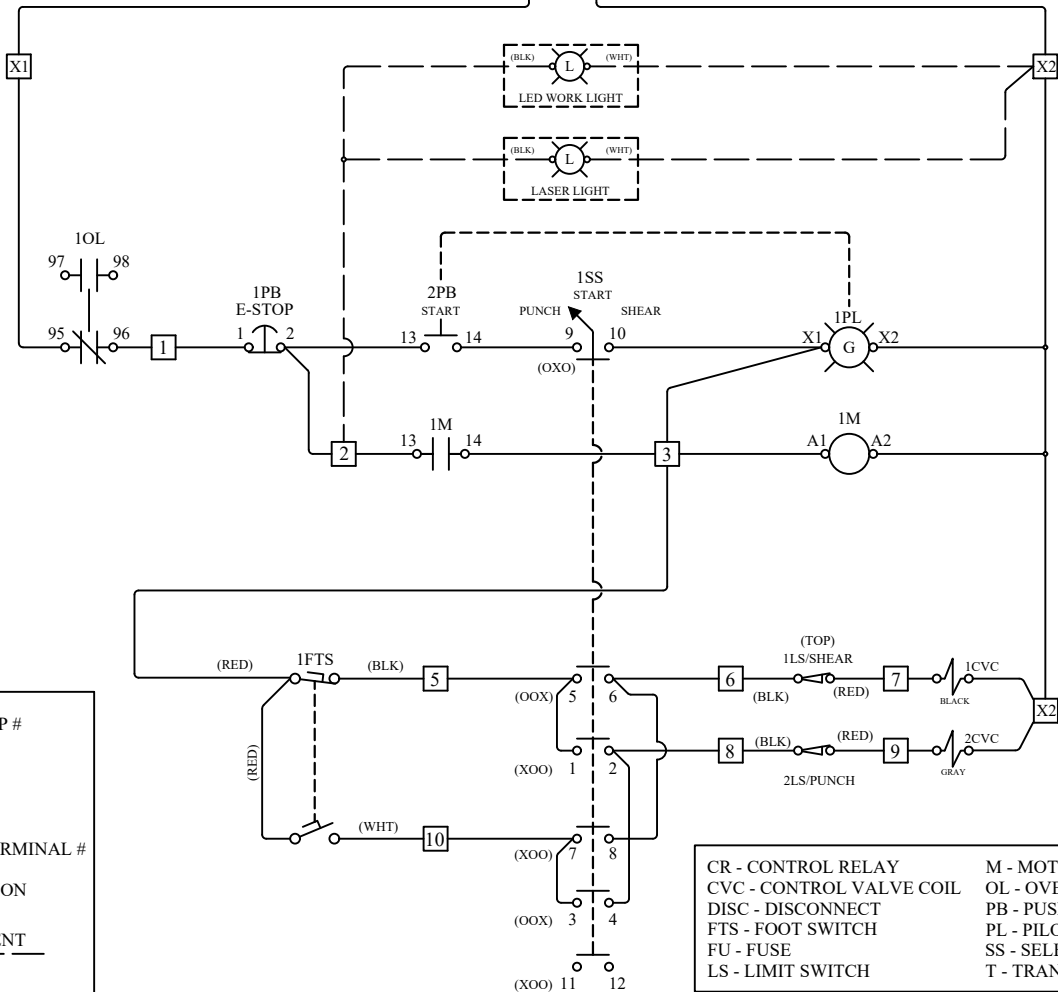
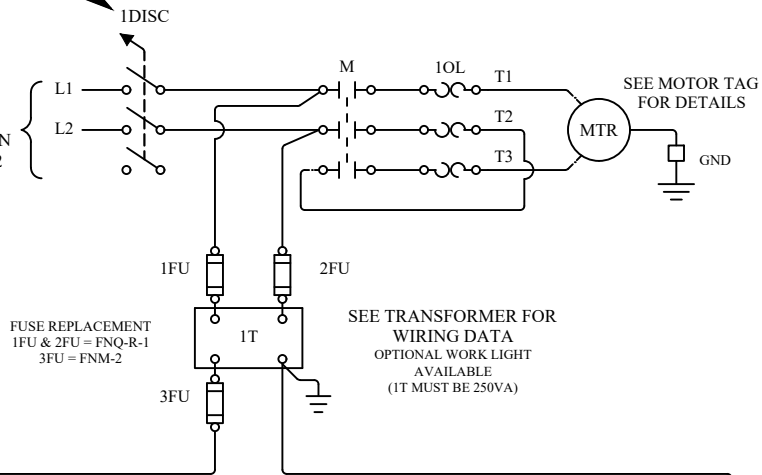

- 1 - TERMINAL STRIP #
- (2) - WIRE #
- BLK - WIRE COLOR
- 3 - COMPONENT TERMINAL #
- (XO) - NORMAL POSITION
- OPTIONAL EQUIPMENT
- COMPONENT

- CR - CONTROL RELAY
- CVC - CONTROL VALVE COIL
- DISC - DISCONNECT
- FTS - FOOT SWITCH
- FU - FUSE
- LS - LIMIT SWITCH
- M - MOTOR START RELAY
- OL - OVERLOAD (THERMAL)
- PB - PUSH BUTTON
- PL - PILOT LIGHT
- SS - SELECTOR SWITCH
- T - TRANSFORMER

**FIGURE 44**



# Three Phase w/ Optional Jog Control

**NOTE:** Incoming Power is wired in easier by unhooking Disconnect Switch from rail. At the bottom of switch there is a white plastic lock. Wedge a straight screw-driver between the lock and switch to remove. Connect wires and snap Disconnect Switch back into place.

PN 520115 RATING TABLE					
LINE VOLTAGE (3PH)	208	230	380	460	575
MAX. HP	3	3	3	3	3
MOTOR FLA	9.8	8.4	4.7	4.2	3.6
OVERLOAD	ZB32-10	ZB32-10	ZB32-6	ZB32-6	ZB32-6

INCOMING SUPPLY (BY CUSTOMER) PROVIDE MAXIMUM UPSTREAM PROTECTION PER N.E.C. CODE 430-52 AND TABLE 430-152.

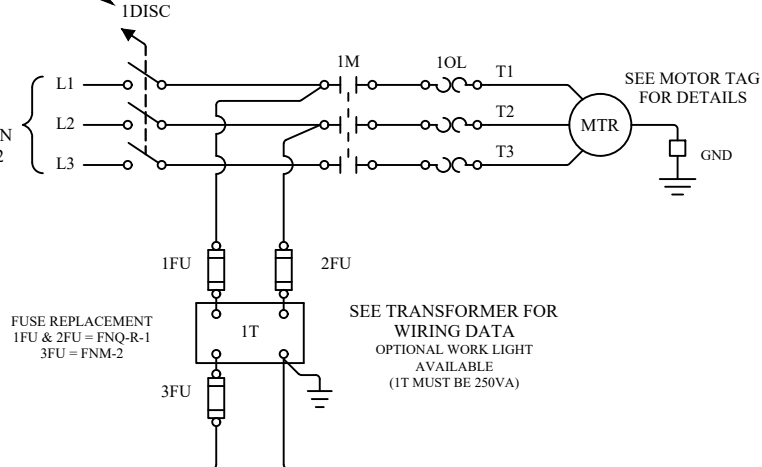

FUSE REPLACEMENT  
1FU & 2FU = FNQ-R-1  
3FU = FNM-2

SEE TRANSFORMER FOR WIRING DATA  
OPTIONAL WORK LIGHT AVAILABLE (IT MUST BE 250VA)

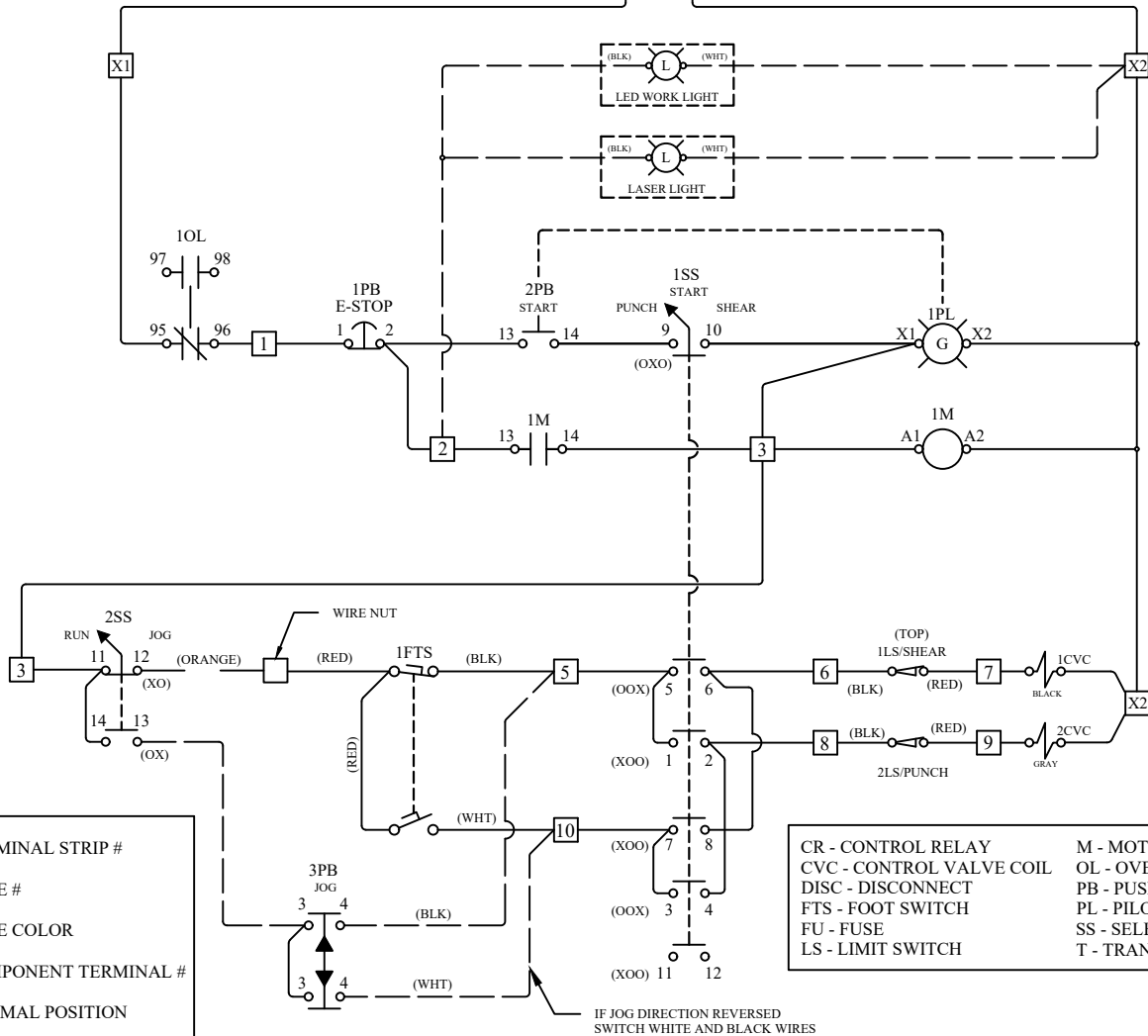

- 1 - TERMINAL STRIP #
- (2) - WIRE #
- BLK - WIRE COLOR
- 3 - COMPONENT TERMINAL #
- (XO) - NORMAL POSITION
- OPTIONAL EQUIPMENT
- COMPONENT

- CR - CONTROL RELAY
- CVC - CONTROL VALVE COIL
- DISC - DISCONNECT
- FTS - FOOT SWITCH
- FU - FUSE
- LS - LIMIT SWITCH
- M - MOTOR START RELAY
- OL - OVERLOAD (THERMAL)
- PB - PUSH BUTTON
- PL - PILOT LIGHT
- SS - SELECTOR SWITCH
- T - TRANSFORMER

**FIGURE 46**

# Single Phase w/ Optional Jog Control

**NOTE:** Incoming Power is wired in easier by unhooking Disconnect Switch from rail. At the bottom of switch there is a white plastic lock. Wedge a straight screw-driver between the lock and switch to remove. Connect wires and snap Disconnect Switch back into place.

PN 520115 RATING TABLE	
LINE VOLTAGE (1PH)	230
MAX. HP	5
MOTOR FLA	21
OVERLOAD	ZB32-24

INCOMING SUPPLY  
(BY CUSTOMER)  
PROVIDE MAXIMUM  
UPSTREAM PROTECTION  
PER N.E.C. CODE 430-52  
AND TABLE 430-152.

FUSE REPLACEMENT  
1FU & 2FU = FNQ-R-1  
3FU = FNM-2

SEE TRANSFORMER FOR  
WIRING DATA  
OPTIONAL WORK LIGHT  
AVAILABLE  
(1T MUST BE 250VA)

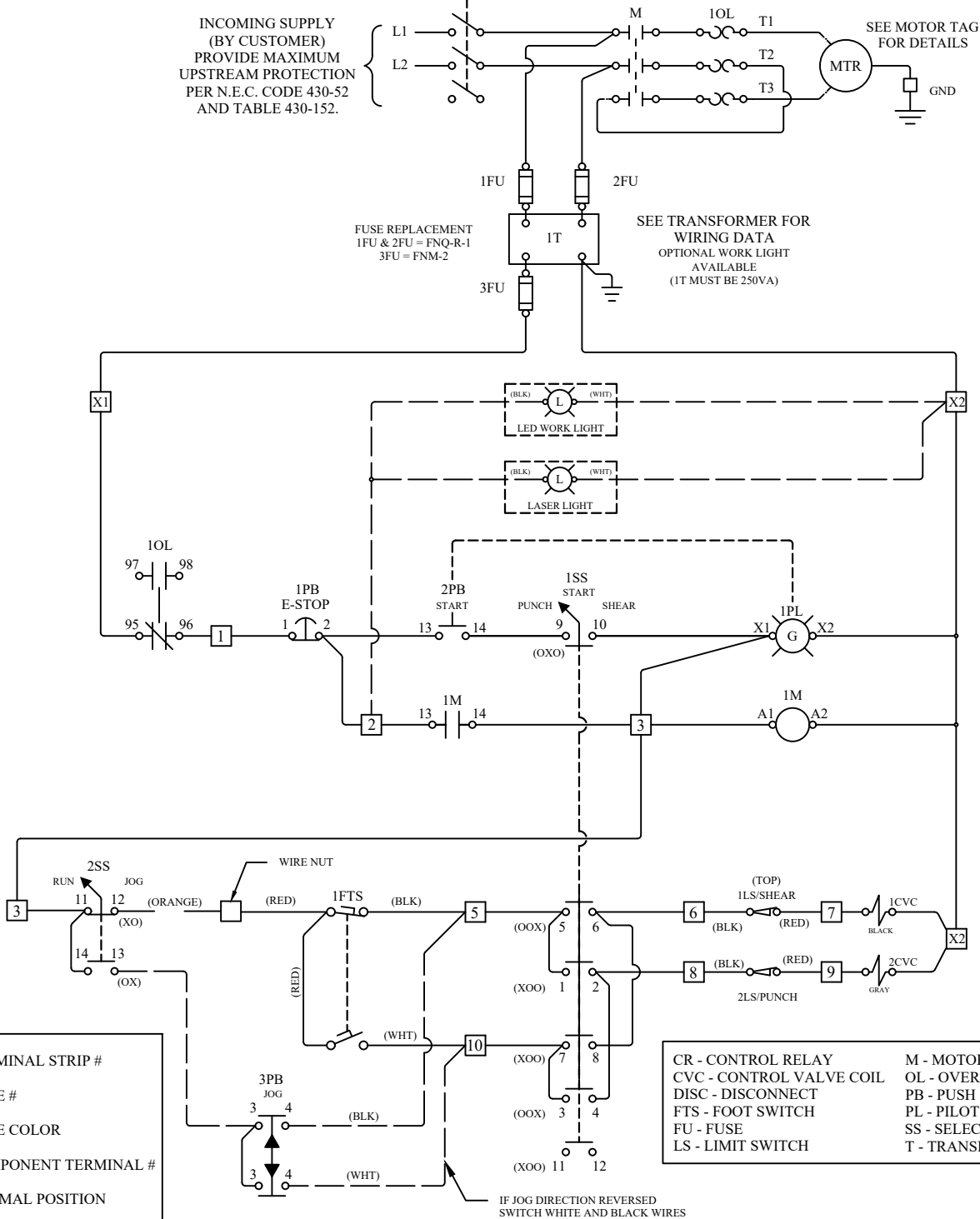

- 1 - TERMINAL STRIP #
- (2) - WIRE #
- BLK - WIRE COLOR
- 3 - COMPONENT TERMINAL #
- (XO) - NORMAL POSITION
- OPTIONAL EQUIPMENT
- COMPONENT

- CR - CONTROL RELAY
- CVC - CONTROL VALVE COIL
- DISC - DISCONNECT
- FTS - FOOT SWITCH
- FU - FUSE
- LS - LIMIT SWITCH
- M - MOTOR START RELAY
- OL - OVERLOAD (THERMAL)
- PB - PUSH BUTTON
- PL - PILOT LIGHT
- SS - SELECTOR SWITCH
- T - TRANSFORMER

**FIGURE 47**

# Optional Jog Control

IF JOG DIRECTION REVERSED  
SWITCH WHITE AND BLACK WIRES

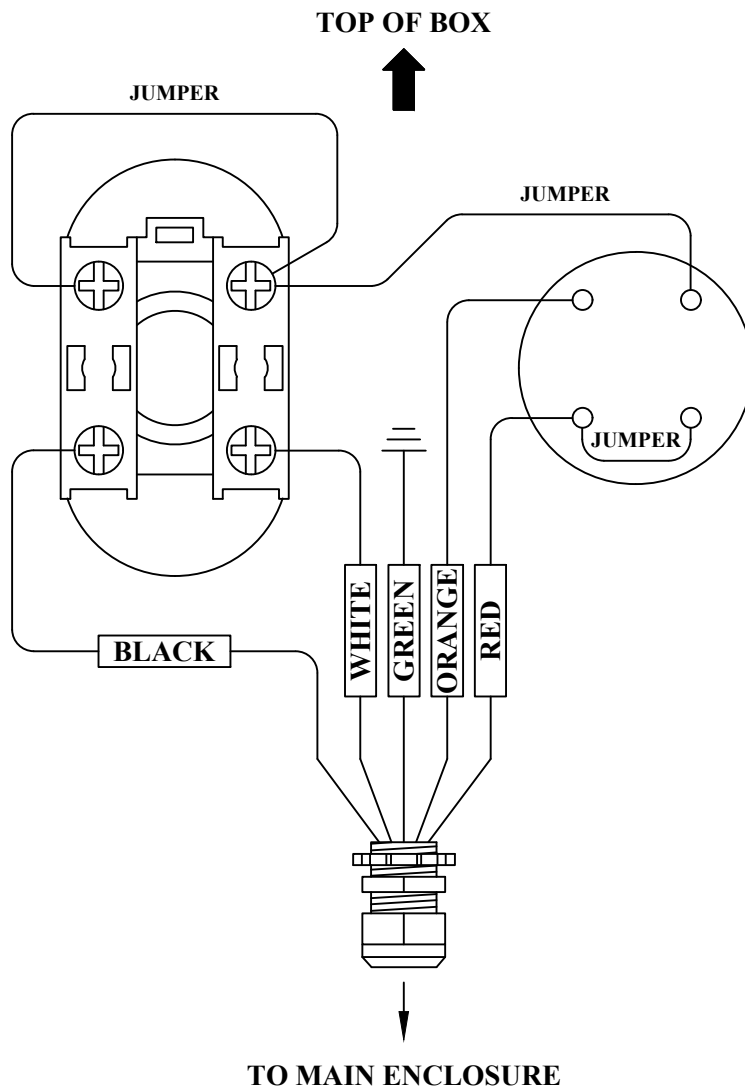
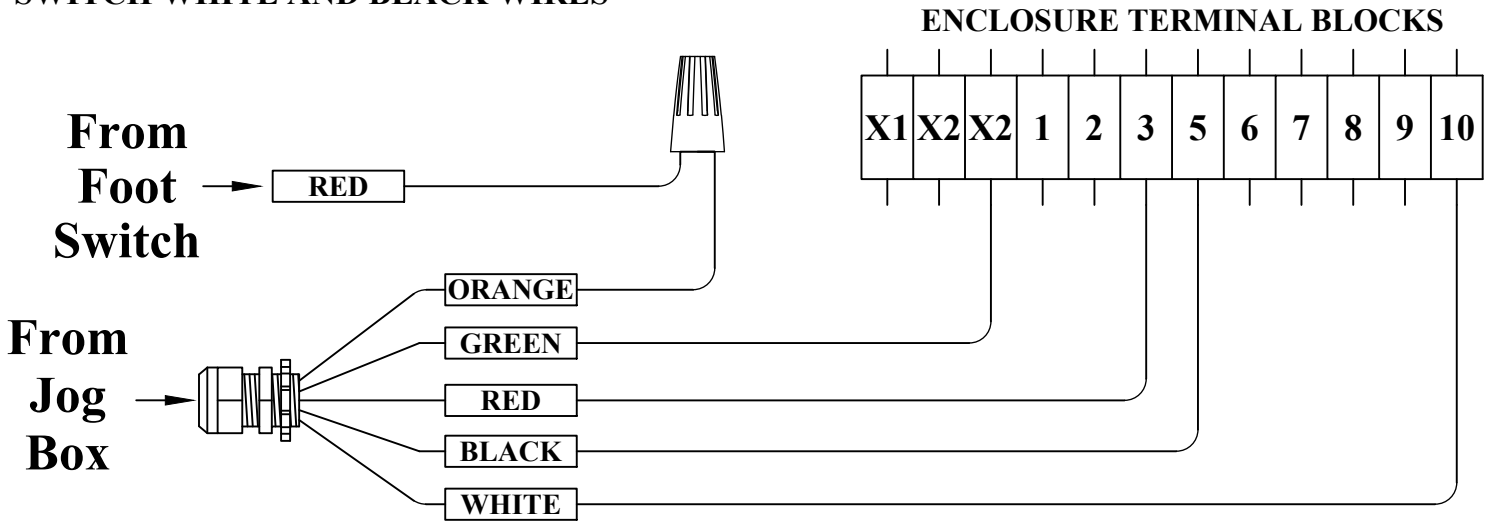
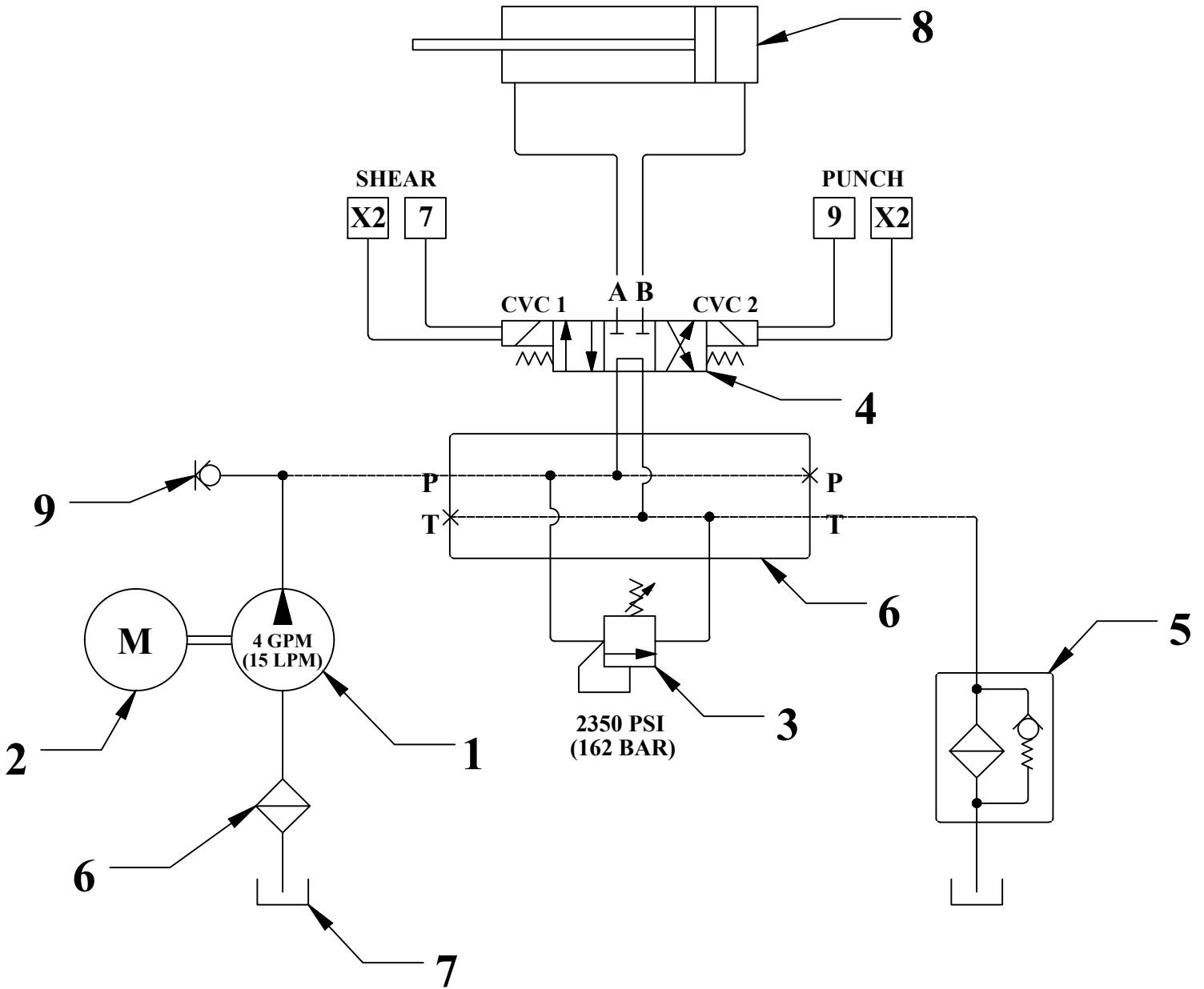

FIGURE 48



# 11.0 HYDRAULIC SCHEMATIC



- 1 = VANE PUMP
- 2 = 3/5 H.P. AC MOTOR
- 3 = PRESSURE RELIEF
- 4 = DO3 4-WAY SOLENOID VALVE
- 5 = RETURN FILTER
- 6 = VALVE MANIFOLD
- 7 = 4 GAL (15L) RESERVOIR
- 8 = DOUBLE ACTING CYLINDER
- 9 = LINE PRESSURE TEST PORT

FIGURE 49