

**You have downloaded a manual for our
Model 9012-24M Ironworker.**

**This manual does not include all of the
optional tooling for this machine.**

**If you would like a tooling manual,
please download our #40 Tooling Manual.**

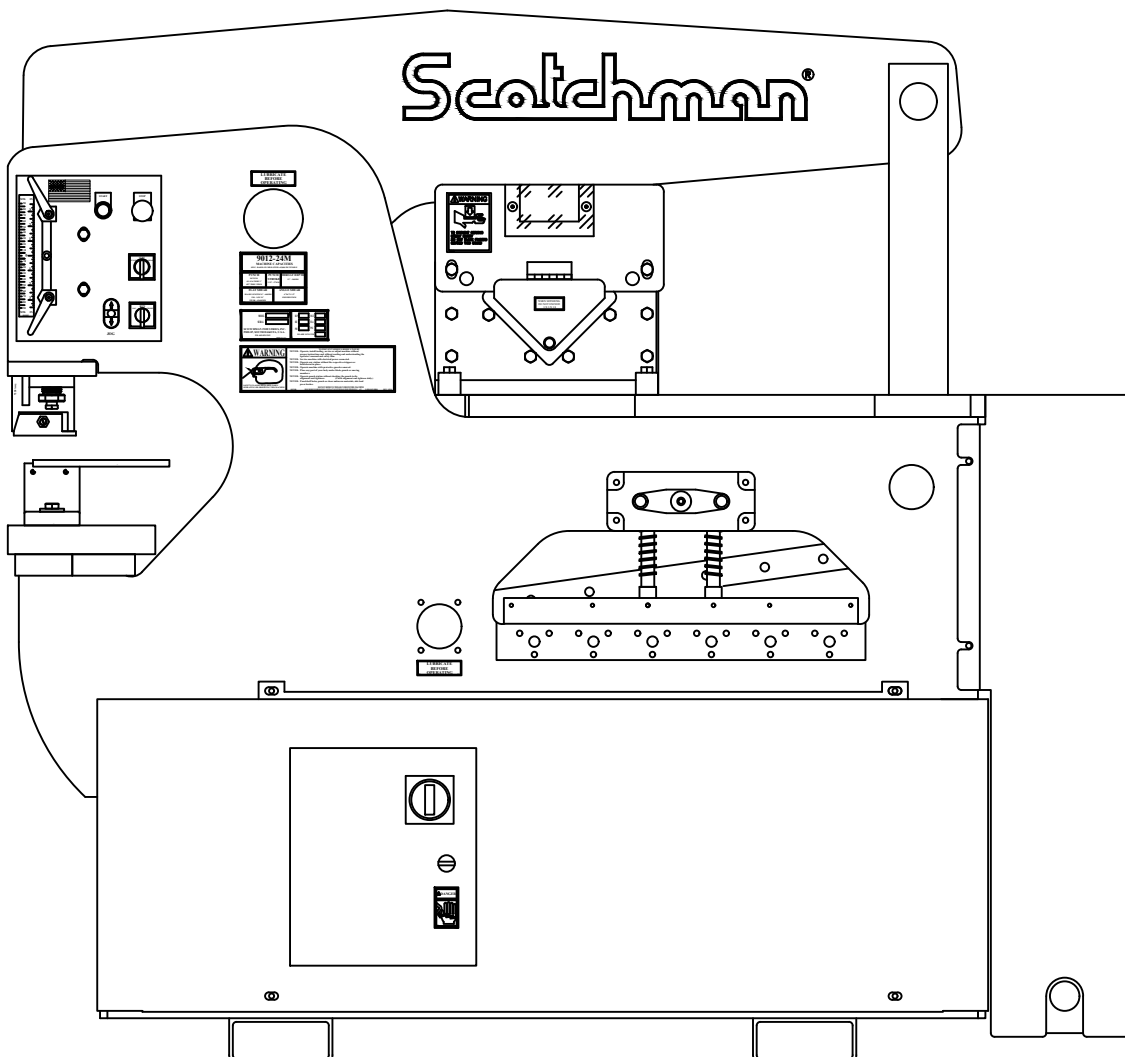



www.scotchman.com

**MODEL
9012-24M
IRONWORKER**

SERIAL # 21998M1221 & UP

PRINTED MAY 2024

TABLE OF CONTENTS

SECTION	DESCRIPTION	PAGE #
1.0	INTRODUCTION	5
2.0	SAFETY PRECAUTIONS	6
2.1	Warranty	7
3.0	WARNING LABELS	8-9
4.0	INSTALLATION & SET-UP	10-19
4.1	Physical Dimensions	10
4.2	Machine Moving Procedures	12
4.3	Physical Inspections	13
4.4	Electrical Requirements	14
4.5	Machine Start Up	17
4.6	Machine Stroke Inspection & Adjustment	18
5.0	MAINTENANCE	20-23
5.1	Lubrication	20
5.2	Routine Lubrication	20
5.3	Scheduled Maintenance	22
6.0	MACHINE OPERATION	24-33
6.1	Punch Operation	24
6.1A	Stripper Adjustment	29
6.2	Bar Shear Operation	30
6.2A	Shear Arm Adjustment	32
6.2B	Shear Blade Adjustment Procedure	34
7.0	OPTIONAL TOOL OPERATION	36-68
7.1	6 x 6 Angle Shear	38
7.1A	6 x 6 Angle Shear Installation	38
7.1B	6 x 6 Angle Shear Operation	38
7.2	Rod Shear	40
7.2A	Rod Shear Installation	40
7.2B	Rod Shear Operation	40
7.3	6 x 6 Ninety Degree Notcher	42

TABLE OF CONTENTS

SECTION	DESCRIPTION	PAGE #
7.3A	6 x 6 Ninety Degree Notcher Installation	42
7.3B	6 x 6 Ninety Degree Notcher Operation	42
7.3C	Blade Replacement	44
7.4	Rectangle Notcher	44
7.4A	Rectangle Notcher Installation	44
7.4B	Rectangle Notcher Operation	45
7.5	12 & 24 Inch Brakes	46
7.5A	12 & 24 Inch Brake Installation	46
7.5B	12 & 24 Inch Brake Operation	46
7.6	Angle Iron Brake	48
7.6A	Angle Iron Brake Installation	48
7.6B	Angle Iron Brake Operation	48
7.7	Channel Shear	50
7.7A	Channel Shear Installation	50
7.7B	Channel Shear Operation	51
7.8	Pipe Notcher	52
7.8A	Pipe Notcher Installation	52
7.8B	Pipe Notcher Operation	54
7.8C	Pipe Notcher Capacities	54
7.9	Picket Tool Installation & Operation	55
7.10	Square Tube Shear	56
7.10A	Square Tube Shear Installation	56
7.10B	Square Tube Shear Operation	56
7.11	Optional Punch and Die Holders	58
7.11A	2-1/2" & 3" Die Inserts	58
7.11B	Offset Die Holder For Flange Punching	58
7.11C	6 x 6 Die Holder	58
7.11D	# 45 Punch Retaining Nut	58
7.11E	Heavy Duty Split Ring Retaining Nut	59
7.12	Optional Gauging Equipment	60
7.12A	48 Inch Deluxe Back Gauge	60
7.13	Urethane Stripper	60
7.13A	Changing The Urethane Springs	60
7.13B	Instlling The Urethane Stripper & Punch & Die	62

TABLE OF CONTENTS

SECTION	DESCRIPTION	PAGE #
7.14	Weld Coupon Bender Tool	64
7.14A	Weld Coupon Bender Tool Installation	64
7.14B	Weld Coupon Bender Tool Operation	64
7.15	Multi-Shear Tool	66
7.15A	Multi-Shear Tool Installation	66
7.15B	Multi-Shear Tool Operation	66
8.0	TROUBLE SHOOTING GUIDE	69-73
8.1	Electrical Trouble Shooting-Motor	69
8.2	Limit Switch Inspection Procedure	70
8.3	Control Valve Inspection	70
8.4	Hydraulics	71
8.5	Cylinder Seal Replacement	72
9.0	9012 IRONWORKER PARTS LISTS	74-95
9.1	Shear Arm Assembly - S/N 21601M & Up	74
9.2	Punch Assembly	76
9.3	Stripper Assembly	78
9.4	Upper Arm Assembly	80
9.5	Upper Panel & Stroke Control	82
9.6	Hold Down Assembly	84
9.7	Cylinder Assembly & Shrouds	86
9.8	Connecting Link Assembly	87
9.9	Power Unit - Serial # 20661M & Up	88
9.10	Electrical Unit	90
9.11	Urethane Stripper	94
10.0	SUPPLEMENT FOR OLDER MODELS	96-99
10.1	Shear Arm Assembly - S/N 21600M & Prior	96
10.2	Shear Blade Adjustment Procedure - S/N 21600M & Prior	98

1.0 INTRODUCTION

The Scotchman 9012-24M is a versatile, multi-purpose, shearing, punching and forming machine engineered for trouble free operation. The design of the machine combines simplicity of operation with smooth, full stroke control. The ability of the operator to control the machine's direction of movement at any point in the stroke (stop, jog or reverse) gives the Scotchman 9012-24M Ironworker a tremendous advantage over mechanical ironworkers. There is no chance of the Scotchman being "accidentally tripped". The hydraulic system operates at a maximum pressure of 2,650 PSI (183 BAR) and is protected from overload by a pilot operated relief valve. The Scotchman 9012-24M Ironworker lends itself to a variety of special purpose tools that can be mounted on the tool table where a selection of power and stroke potentials are available.

2.0 SAFETY PRECAUTIONS

- 1. The operators of this machine must be qualified and well trained in the operation of the machine. The operators must be aware of the capacities of the machine and the proper use of the hold down devices, strippers and guards provided with the machine.**
- 2. All of the guards, adjustable restrictors and awareness barriers must be installed on the machine and kept in good working order. Promptly replace worn or damaged parts with authorized parts.**
- 3. Never place any part of your body into or under any of the machine's moving parts, strippers or hold devices.**
- 4. Wear the appropriate personal protective equipment. Safety glasses are required at all times, whether operating, setting up or observing this machine in operation. Since heavy pieces of metal with sharp edges can be processed on this machine, the operator should also wear steel-toed shoes and tight fitting leather gloves.**
- 5. Strictly comply with all warning labels and decals on the machine. Never remove any of the labels. Replace worn or damaged labels promptly.**
- 6. Always disconnect and lock out the power when performing maintenance work or setting up any tooling on the machine. Follow the procedures outlined in the operator's manual for setting up, changing or aligning any tooling on this machine.**
- 7. Never operate this machine with dull or damaged tooling. Replace worn punches, dies and blades promptly.**
- 8. Practice good housekeeping. Keep the area around the machine clear and well lit. Do not obstruct the operator's position by placing anything around the machine that would impede the operator's access to the machine.**
- 9. Never modify this machine in any way without the written permission of the manufacturer.**
- 10. Never leave this machine running unattended.**
- 11. Always operate the punch station facing the station, standing. Never operate any of the work stations from a sitting or kneeling position.**
- 12. Set up a program of routine inspections and maintenance for this machine. Make all repairs and adjustments in accordance with the manufacturer's instructions.**
- 13. A safety video for this machine is available online at scotchman.com. Also, our YouTube channel has the safety video as well as many other helpful & informative videos related to this machine.**

**IT IS HIGHLY RECOMMENDED THAT ANYONE WHO OPERATES THIS
MACHINE SHOULD VIEW AND UNDERSTAND THE SAFETY VIDEO**

If this machine was purchased used, watch the safety video - Its free and can be viewed online and at any time.

2.1 WARRANTY

Scotchman Industries Inc. will, within three years of date of purchase, replace F.O.B. the factory or refund the purchase price for any goods which are defective in materials or workmanship, provided that the buyer returns the warranty registration card within thirty days of the purchase date and, at the seller's option, returns the defective goods freight and delivery prepaid to the seller, which shall be the buyer's sole and exclusive remedy for defective goods.

Hydraulic and electrical components are subject to their respective manufacturer's warranties.

This warranty does not apply to machines and/or components which have been altered, changed or modified in any way or subjected to abusive and abnormal use, inadequate maintenance and lubrication or subjected to use beyond the seller's recommended capacities and specifications.

In no event shall seller be liable for labor cost expended on such goods or consequential damages.

The seller shall not be liable to purchaser or any other person for loss or damage directly or indirectly arising from the use of the goods or from any other cause.

No officer, employee or agent of the seller is authorized to make any oral representations or warranty of fitness or to waive any of the foregoing terms of sale and none shall be binding on the seller.

Any electrical changes made to the standard machine due to local electrical code variations must be paid by purchaser.

As we constantly strive to improve our products, we reserve the right to make changes without notification.

3.0 WARNING LABELS

ITEM	QTY	PART #	DESCRIPTION
A	1	003100	Large Safety Glasses
B	1	003105	Fingers Beyond Bar Guard
C	1	003110	Punch & Die Warning
D	1	003122	Danger Voltage Sticker
E	2	003140	Finger Beyond Tool Shear
F	1	019127	U.S. Flag Decal
G	1	003195	3 x 3 x 1/4 Max Sticker
H	1	010117	27" Scotchman Decal
I	1	019139	90T Capacity Decal
J	4	019103	Lubricate Decal
K	7	019105	Grease Point Decal
L	1	003175	Caution Contamination (Not shown.)
M	1	019102	Reservoir Capacity (Not shown.)
N	1	003540	90T Decal Package

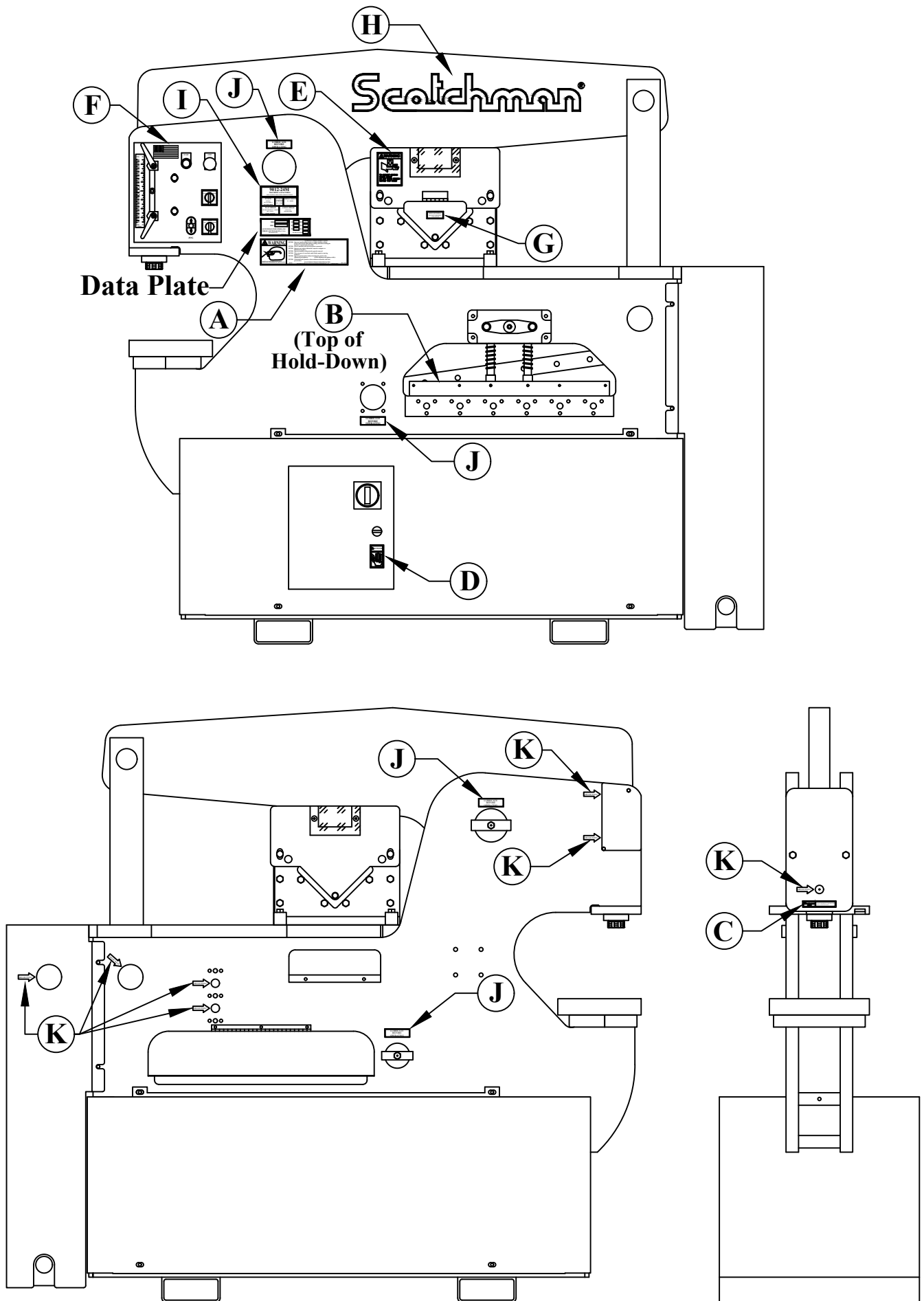

FIGURE 1

4.0 INSTALLATION & SET UP

⊗ **CAUTION: THIS SECTION DISCUSSES INSTALLATION AND SET-UP PROCEDURES. PLEASE READ THOROUGHLY BEFORE OPERATING THIS MACHINE.**

4.1 PHYSICAL DIMENSIONS

This machine is designed to be moved with a forklift. The weight of this machine is 4,000 pounds (1,814 Kg.). Check the capacity of the lifting equipment before attempting to move the machine.

ITEM	DESCRIPTION	INCHES	CM
1	Floor to Punch Ram	43-3/16	109.7
2	Floor to top of Die Holder	41	104.1
3	Floor to Punch Bolster	36-3/8	92.4
4	Floor to Bottom Rail	3	7.6
5	Floor to Bar Shear	29-13/16	75.7
6	Floor to Tool Table	45-3/16	114.8
7	Height	71-1/2	181.6
8	Length	76-3/4	195
9	Punch Stroke	2-1/4	5.7
10	Width	31	78.4
11	Weight	4,204 LBS.	1,907 KG.

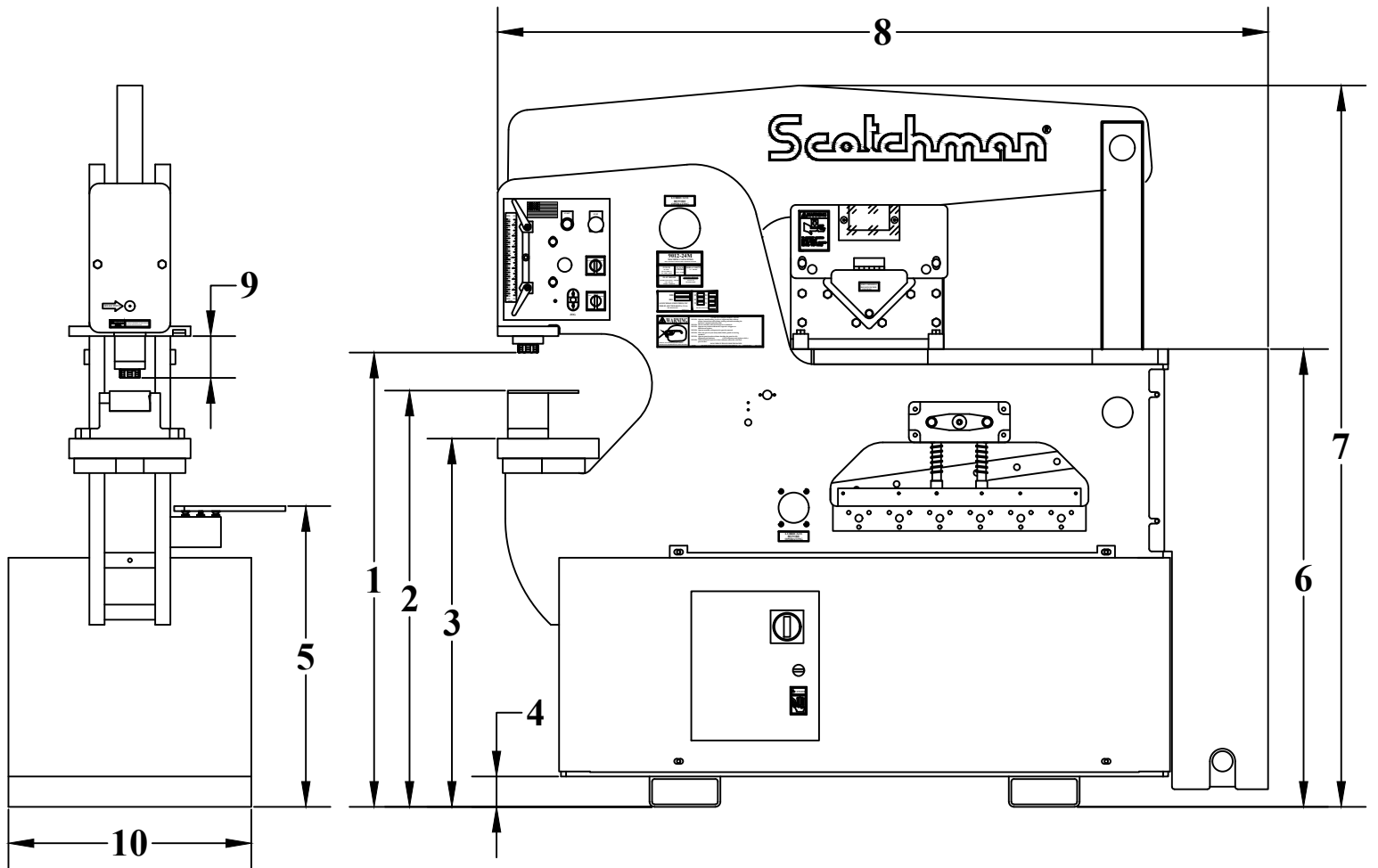

FIGURE 2

4.2 MACHINE MOVING PROCEDURES

This machine is designed to be moved with a forklift. The weight of this machine is 4,204 pounds (1,907 Kg.). Check the capacity of the lifting equipment before attempting to move the machine.

- ➔ **THIS MACHINE IS TOP HEAVY AND SHOULD BE MOVED WITH CARE AND ON FLAT SURFACES ONLY.**

This is the quickest and safest means of moving the machine. The forks of the lift should be spread so that they fit inside the lifting channels provided.

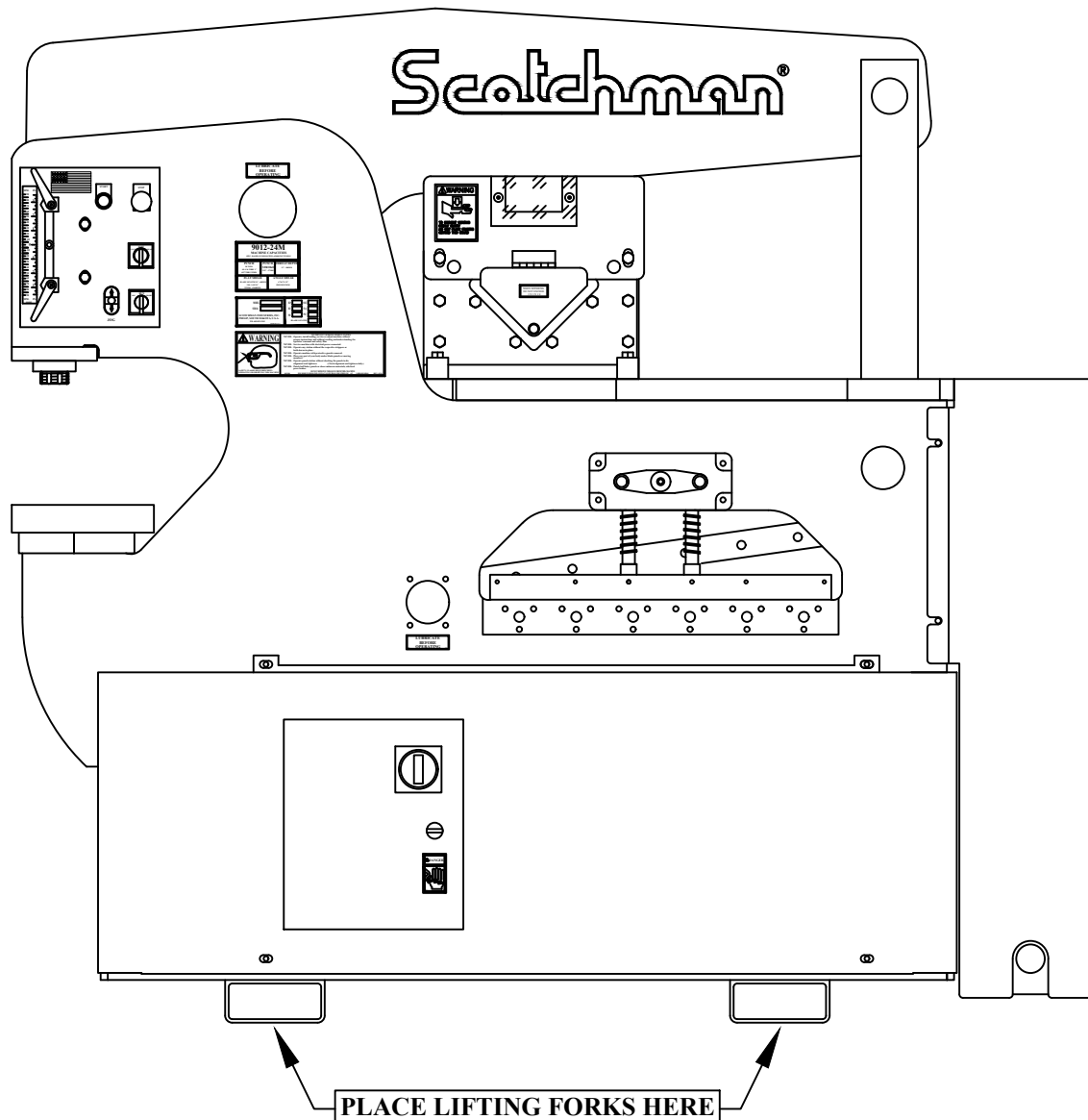

FIGURE 3

4.3 PHYSICAL INSPECTIONS

After the machine has been located, remove the side shrouds and inspect the interior of the machine for possible shipping damages.

CHECK SPECIFICALLY THE FOLLOWING ITEMS:

- A. Stroke control handles and limit switches.**
- B. Pump and motor assembly.**
- C. Hydraulic hoses and fittings.**
- D. Starter box and control box.**
- E. Electrical connections.**
- F. Control valve.**
- G. A general inspection of the machine shrouds, guards and awareness barriers.**
- H. Check the re-pack box for all accessory items ordered with the machine.**

The reservoir is full of oil. The recommended oil is a lightweight, non-foaming, anti-wear, hydraulic oil such as Mobil DTE-25, with a minimum ISO cleanliness code of 20/18/15, or equivalent.

The reservoir holds 13.5 U.S. gallons (51 liters).

⊠ CAUTION: DO NOT OVER FILL!

4.4 ELECTRICAL REQUIREMENTS

PN 011898 RATING TABLE					
LINE VOLTAGE (3PH)	208	230	380	460	575
MAX. HP	5	5	5	5	5
MOTOR FLA	14	12.6	7.7	6.3	5.1
OVERLOAD	ZB32-24	ZB32-24	ZB32-10	ZB32-10	ZB32-10

3-PHASE POWER

INCOMING SUPPLY
(BY CUSTOMER)
PROVIDE MAXIMUM
UPSTREAM PROTECTION
PER N.E.C. CODE 430-52
AND TABLE 430-152.

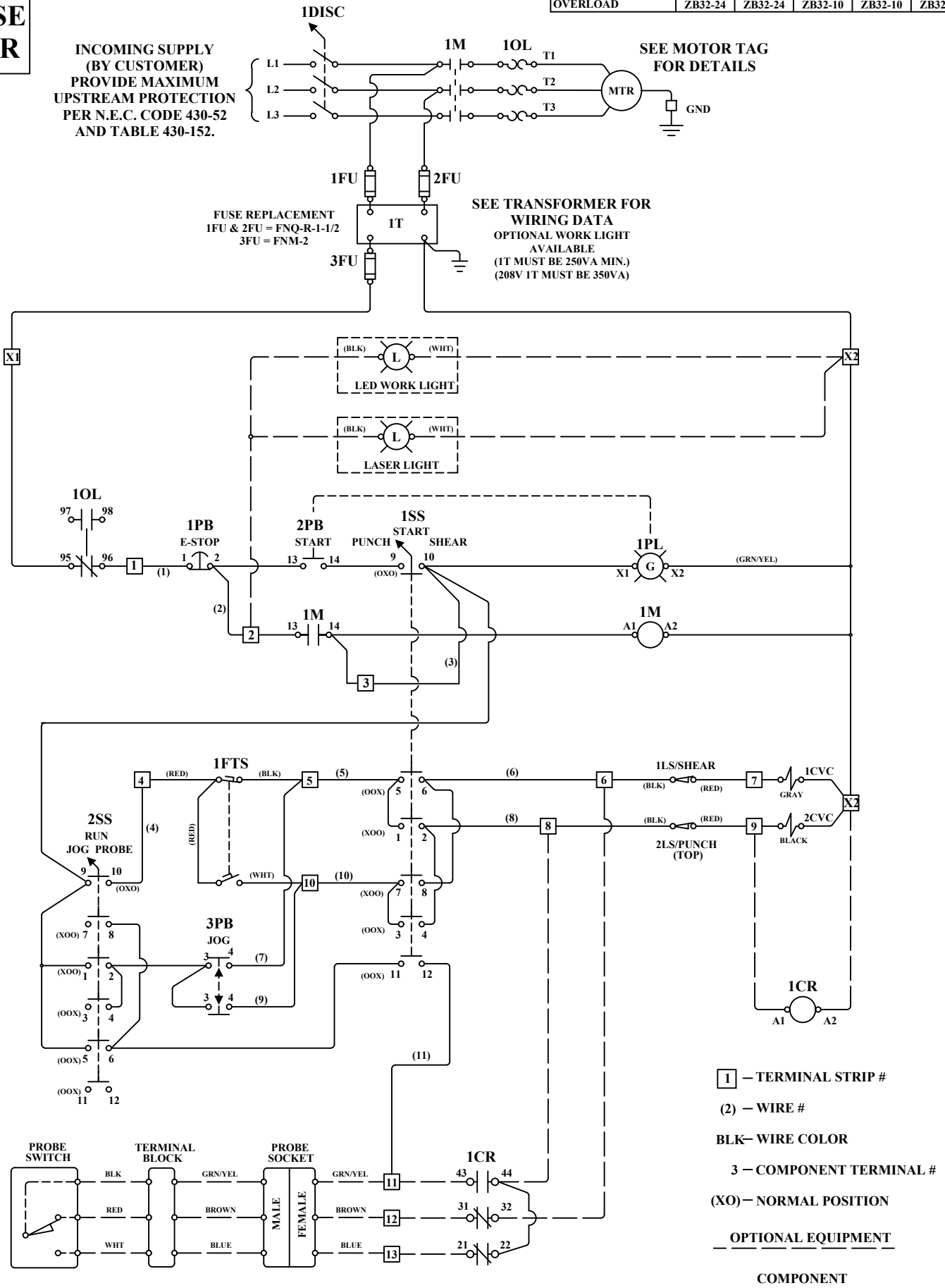

FIGURE 4

SINGLE PHASE POWER

PN 011898 RATING TABLE	
LINE VOLTAGE (1PH)	230
MAX. HP	5
MOTOR FLA	24.5
OVERLOAD	ZB32-24

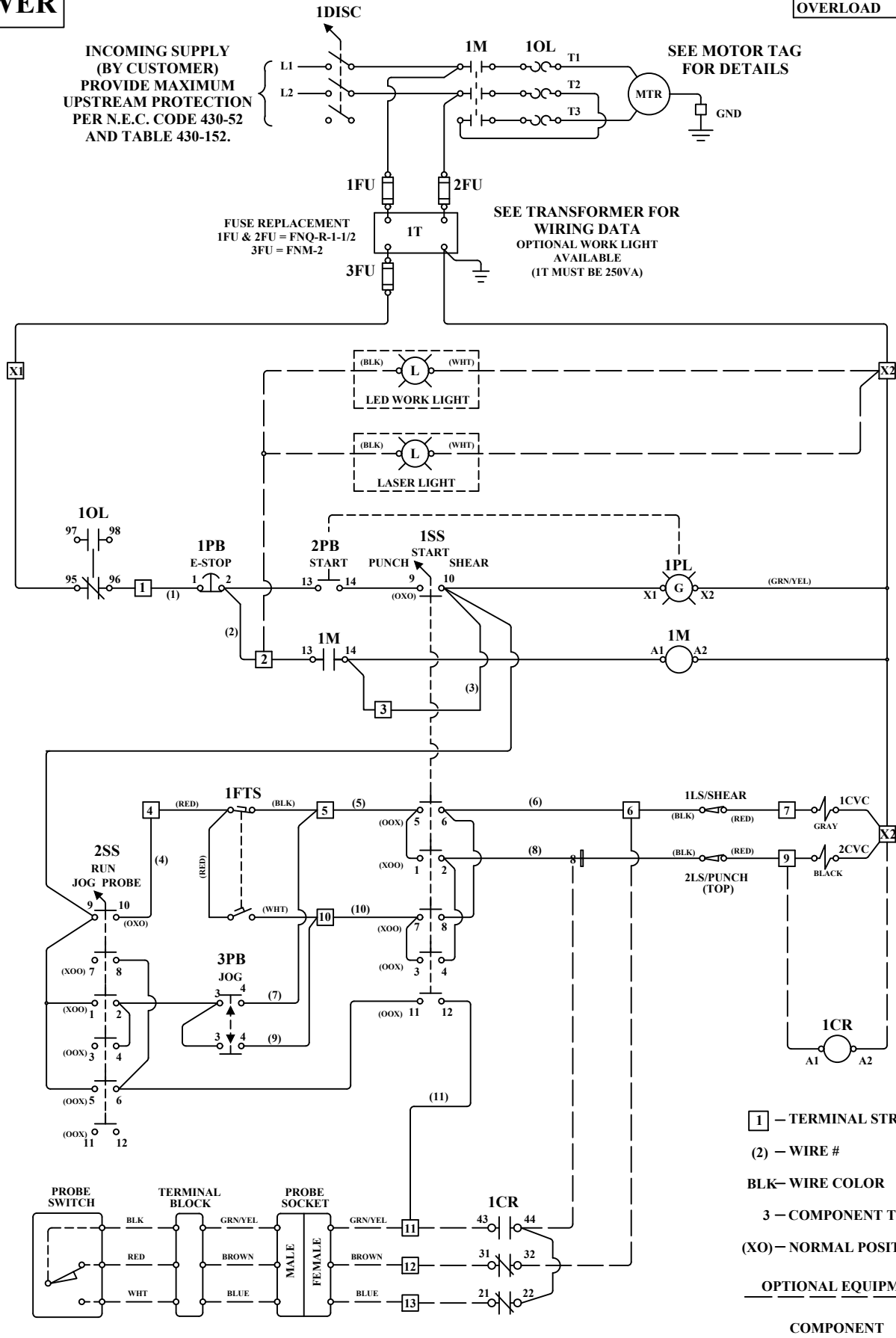

FIGURE 4A

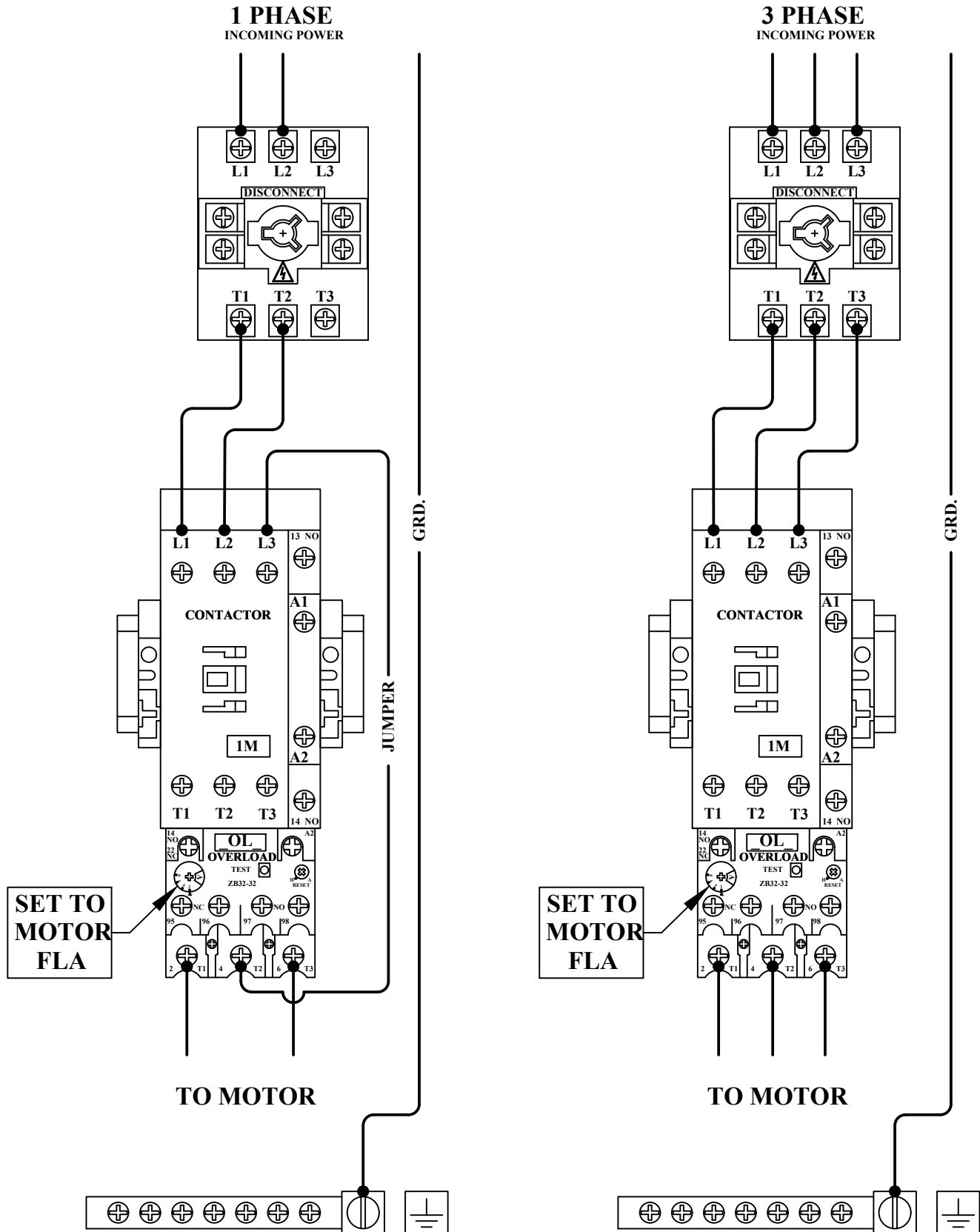
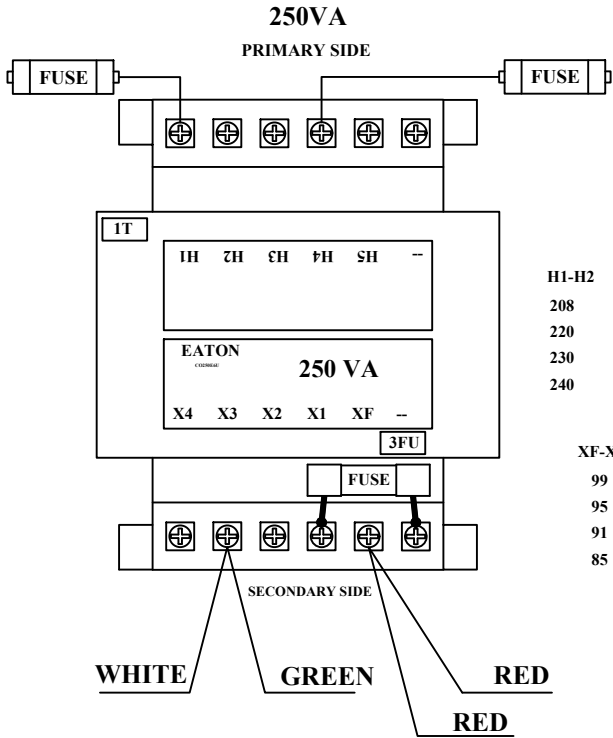

FIGURE 4B

Newer machines (Serial #21750M and up) have the 250 KVA Transformer as standard equipment. Previously, 150 KVA was standard. The 150KVA Transformer is compatible with the LED Light Package.



H1-H2	H1-H3	H1-H4	H1-H5
208	380	440	500
220	400	460	550
230	415	480	575
240			600

XF-X2	XF-X3	XF-X4
99	120	130
95	115	125
91	110	120
85	100	110

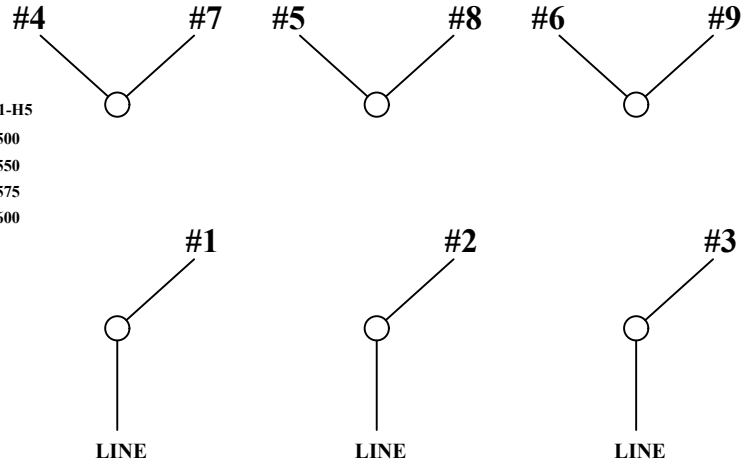

#1 - #9 are Wires From the Motor

208v/277v TRANSFORMER

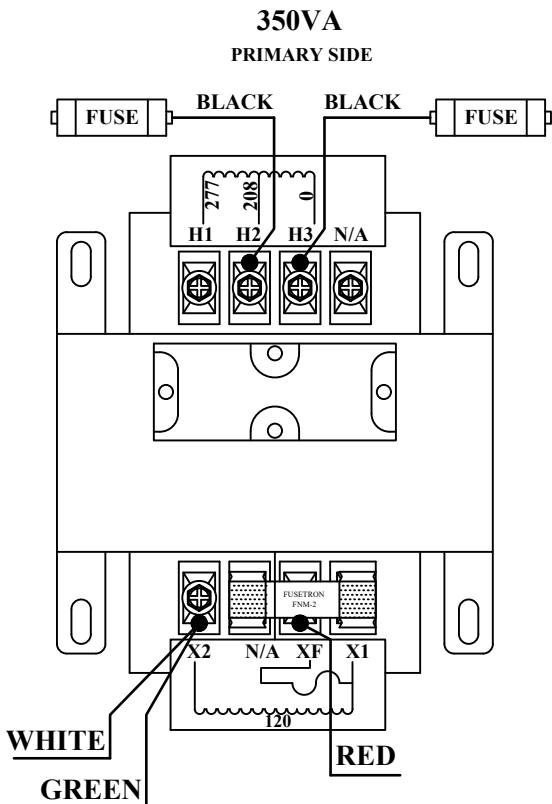

LOW VOLTAGE CONNECTION
(230 VOLT 3PH)

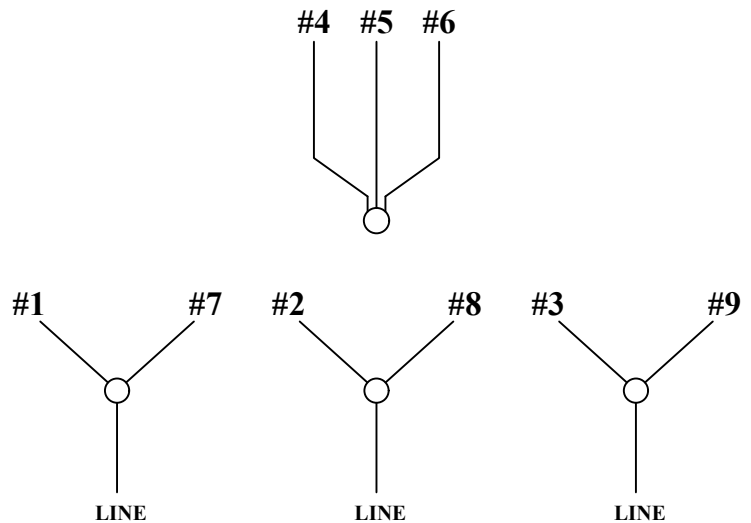

FIGURE 4C

⊗ **CAUTION: TO PREVENT DAMAGE TO THE MOTOR AND DANGER TO THE OPERATOR, ALL ELECTRICAL CONNECTIONS SHOULD BE MADE BY A LICENSED ELECTRICIAN.**

All machines are wired for three phase electrical power unless otherwise specified. To insure satisfactory machine performance, the supply voltage should be (+ or -) 10% of the motor voltage rating. Check the motor data tag for full load current requirements. The electrical diagram for the machine is inside the cover of the control box, and this section has several diagrams for this machine. For electrical supply lines ten feet (3m) or shorter, we recommend at least 12 gauge, and preferably, 10. For longer electrical supply lines, use at least 10 gauge, and preferably, 8. We do not recommend supply lines longer than twenty five feet (7.5m).

POWER REQUIREMENTS

Motor frame	3PH = 182T	1PH = 184T
MOTOR VOLTAGE (VAC)		FULL LOAD CURRENT (AMPS)
208		15.5
230		14
460		7
575		5.9
230 (Single Phase)		23.5
Motor Power Rating:		5hp Speed 1,750 RPM
KVA Power Rating:		5.6 KVA Frequency 60 HZ
Starting Current:		210% Full Load

4.5 MACHINE START-UP

Before starting this machine, take time to thoroughly review the online safety video (at Scotchman.com or on Scotchmans YouTube channel) and the operator's manual. This machine is equipped with a lock-out, disconnect switch. We strongly urge you to follow OSHA directive CFR-1910.147 (effective 09-01-90) regarding lock-out, tag-out procedures. Before powering the machine, be sure that all packing materials and tools have been removed from the machine and that the work stations are clear.

TO POWER THE MACHINE, place the disconnect switch in the ON position and the selector switch in the START position. Power the machine by pushing the green START button. Once the machine has been powered, it will not move until the selector switch has been placed in either the PUNCH or the SHEAR position. Placing the selector switch in the PUNCH position will cause the arms to move down. Placing the selector switch in the SHEAR position will cause the arms to move up. If the machine does not move when the selector switch is placed in the PUNCH or SHEAR position, the motor rotation is not correct and the electrician will have to switch two of the three supply line wires to change the direction of rotation. Any time that the power to the machine has been turned off, the selector switch must be placed in the START position to restart the machine.

Scotchman

M A D E I N U S A



WWW.SCOTCHMAN.COM

4.6 MACHINE STROKE INSPECTION & ADJUSTMENT

The stroke setting is important for the proper operation of the machine. If this setting has changed, the machine may over-travel and cause the cylinder to "bottom out". This continued condition will eventually cause the starter overload to open. It can also cause the hydraulic oil to overheat and damage hydraulic system components. A slight change in the stroke setting can result in inadequate stroke to operate the tooling.

A check of the machine's stroke setting is made at the punch station; SEE FIGURE 5 ON THE FOLLOWING PAGE. Set the stroke control handles (A) out to their farthest position. Turn the selector switch (G) to the START position and power the machine. Then place this switch in the SHEAR position. Measure the distance from the top of the punch bolster to the bottom of the punch ram. The distance should be 9-1/32 inches (229mm). Turn the selector switch to the PUNCH position and measure the distance. The distance should be 6-25/32 inches (172mm).

These dimensions are are + or - 1/16 of an inch (3mm).

IF THE STROKE IS OUT OF THESE LIMITS, THEN USE THE FOLLOWING PROCEDURE:

1. Loosen the two mounting plate screws (D) that hold the mounting plate to the machine. SEE FIGURE 5 ON THE FOLLOWING PAGE.
2. Move the plate vertically, up or down. Moving the plate up will bring the distance down and a movement down will bring the distance up.
3. Tighten the screws and re-check the dimensions. Repeat, if needed.

- A. STROKE CONTROL HANDLES
- B. SCALE - STROKE CONTROL
- C. METERING BOSS
- D. MOUNTING PLATE SCREWS
- E. JOG CONTROL
- F. JOG/RUN/PROBE SWITCH
- G. PUNCH/START/SHEAR SWITCH
- H. EMERGENCY STOP SWITCH
- I. START BUTTON

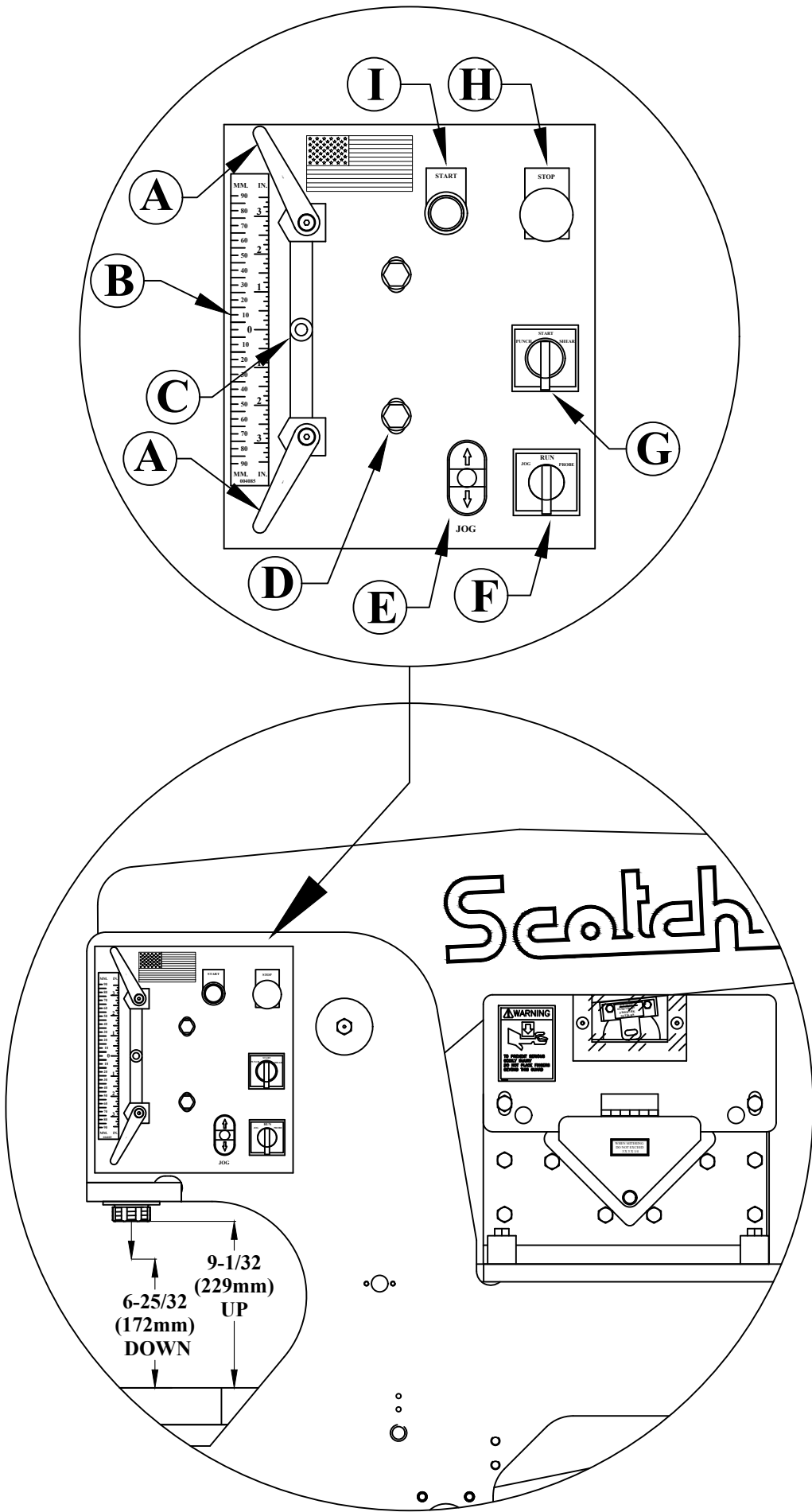

FIGURE 5

5.0 MAINTENANCE

The Scotchman Ironworker is an exceptionally rugged machine designed for long life with a minimum amount of maintenance. A regular program of servicing will extend the life of the machine and prevent costly down time.

5.1 LUBRICATION

IMPORTANT: Before operating the 9012-24M, apply oil to the angle shear blades, bar shear blades and the punch and die. Re-oil punches and dies every 5 to 10 holes and blades every 10 to 15 cuts. The oil will allow the machine to shear, punch and strip more easily and increase tool life considerably. (We recommend cutting oil or motor oil swabbed on with a brush or applied with a squirt can or a spray applicator.)

5.2 ROUTINE LUBRICATION

Grease the main pins (A & B) and the punch ram (C) daily.

(SEE FIGURE 6 ON THE FOLLOWING PAGE.)

Grease all other fittings (D, E, F, & G) twice per week.

A multi-purpose, Molybdenum Disulfide (Dow Corning BR-2 or equivalent) high pressure bearing grease is recommended.

Check the oil level in the reservoir at least once a month. It should be 1 inch below the top of the reservoir.

Change the hydraulic oil and filter at least once a year; more often under adverse conditions.

TO CHANGE THE HYDRAULIC OIL, TURN THE MACHINE'S POWER OFF.

Remove the drain plug from the bottom of the reservoir. Allow the oil to drain. Replace with 13.5 U.S. gallons (51 liters) of lightweight, non-foaming, hydraulic oil such as Mobil DTE-25, with a minimum ISO cleanliness code of 20/18/15, or equivalent.

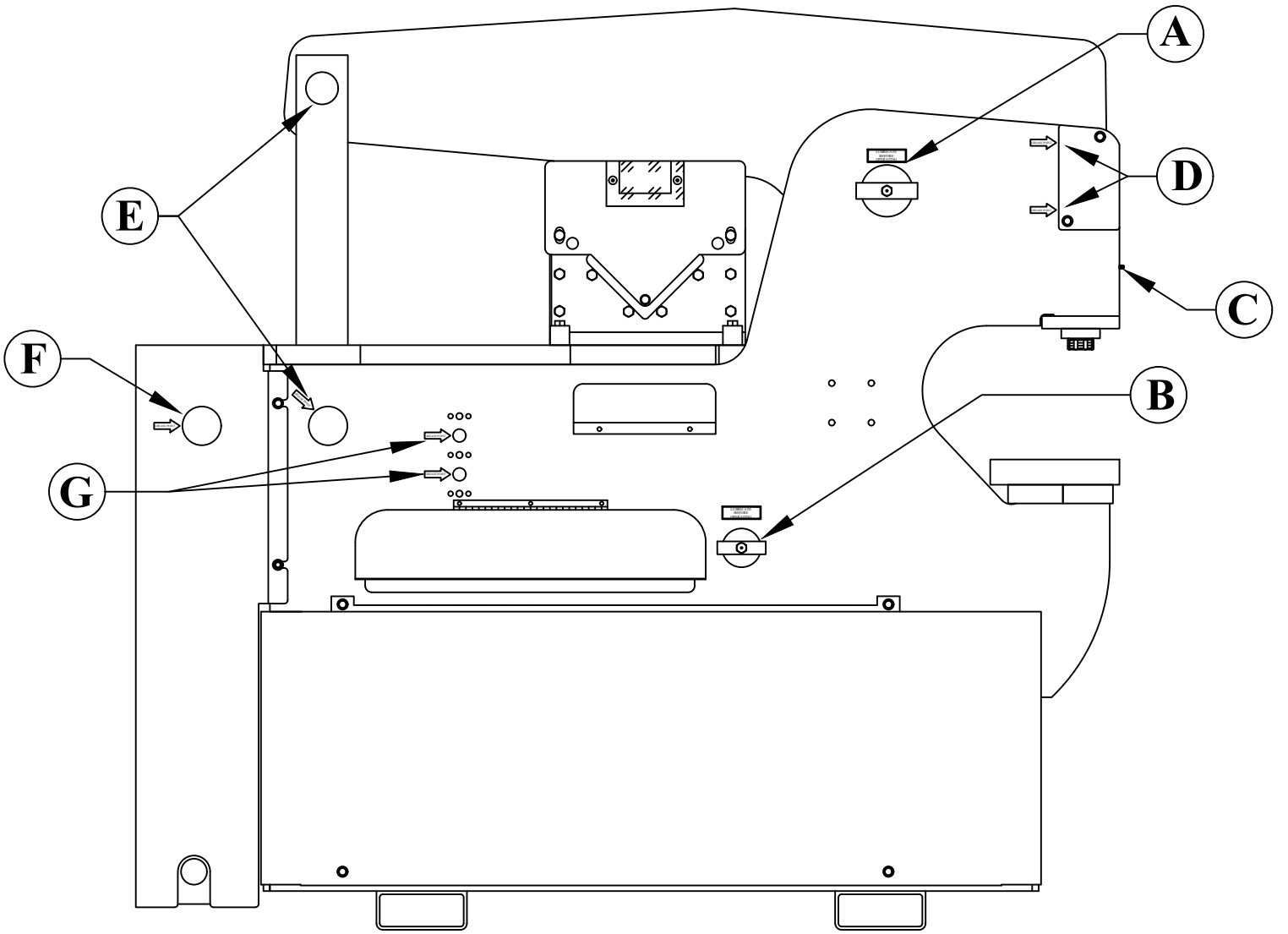

FIGURE 6

5.3 SCHEDULED MAINTENANCE

A program of scheduled maintenance should be set up and documented according to your application and the frequency you use this machine. The following is a list of important items that should be included in a scheduled maintenance program:

EVERY 500 HOURS OR SIX MONTHS:

- A. Check the tolerance between the punch ram and the punch ram bushing.**
To check the tolerances, remove the punch ram and the bushing from the machine. For parts identification, SEE FIGURE 7 ON THE FOLLOWING PAGE.
- 1. To remove the punch ram and bushing, first remove the die holder (A). The stripper (B), the punch ram shroud (C) and the punch pin cover (D).**
 - 2. Cycle the machine until the lower punch pin (E) aligns with the access hole in the rear frame. Turn the power off.**
 - 3. Block up the punch ram (F).**
 - 4. Remove the two mounting bolts and washers (G) from the stroke control mounting plate. Be careful with the wires.**
 - 5. Remove the two snap ring retainers (H) from the lower punch pin. Remove the four mounting bolts (I) and the grease zerk (J) from the punch ram bushing. The meter boss (K) can be left on the lower punch pin. Push the pin out through the access hole in the rear frame.**
 - 6. Remove the punch ram (F) and the bushing (L). Care should be taken when removing these parts; THEY ARE HEAVY.**
 - 7. Clean all grease and dirt off both parts and check the clearance between the outside diameter of the punch ram and the inside diameter of the punch ram bushing. If the clearance between the two parts is five thousandths (.005) or more, replace both parts. Reassemble parts in reverse order.**
- B. Check the condition of the cutting blades on the bar shear, angle shear and any other component tool.**
- C. Check the condition of the bushing in the upper arm and shear arm. This can be done by visually watching the arms for vertical movement while the machine is in operation.**
If vertical movement is noted, block or support the arms with a lifting device and remove the pin and check the clearance. If the clearance between the pin and the bushing exceeds twelve (.012) thousandths (.3mm), replace the bushing. Since the 9012-24M can be used for a wide variety of applications with many optional tools, these may not be all of the items that you need to include in a scheduled maintenance program. If you have questions about other applications, contact your local dealer or the factory.

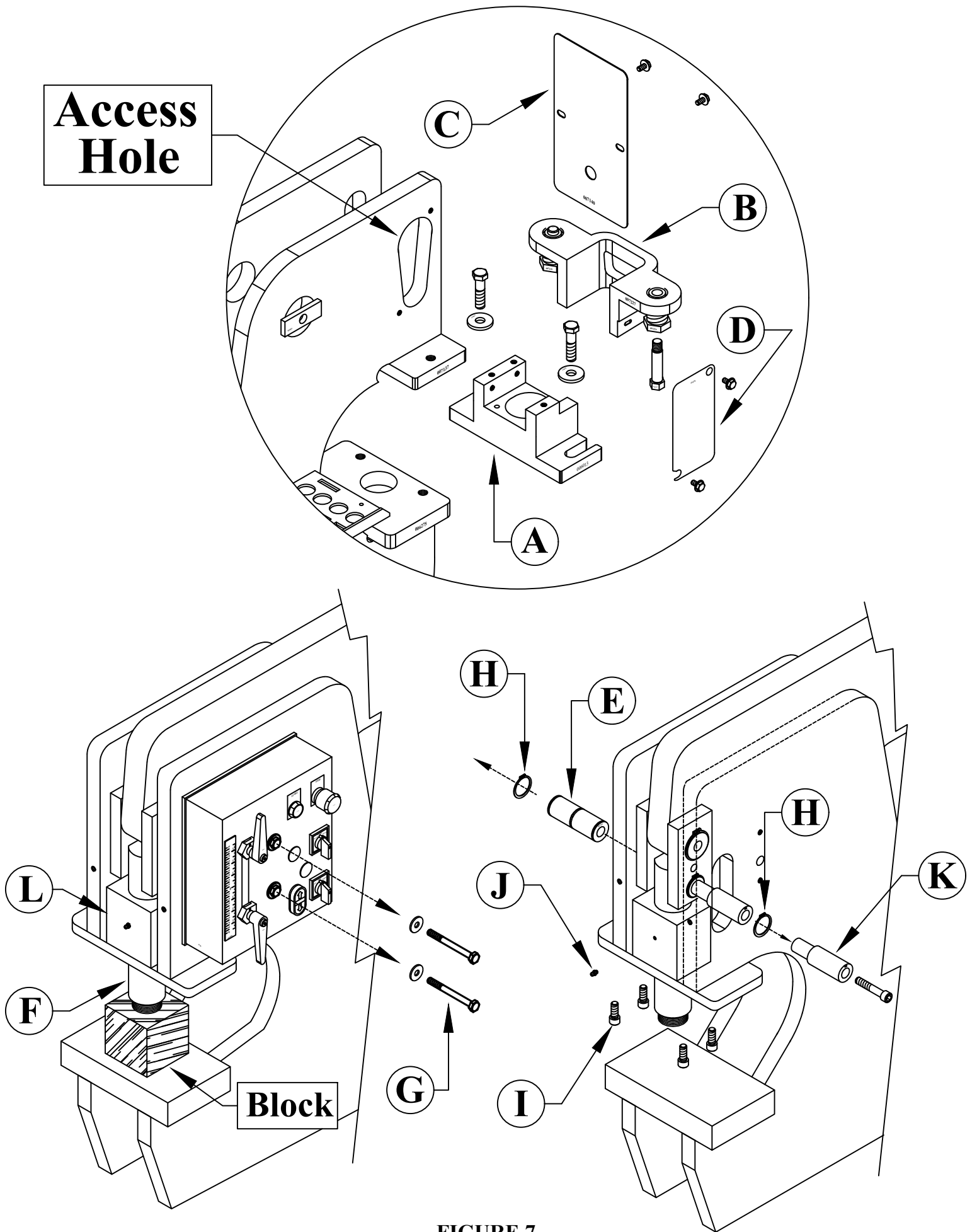

FIGURE 7

6.0 MACHINE OPERATION

6.1 PUNCH OPERATION

➔ ALWAYS WEAR SAFETY GLASSES

THE FIRST AND MOST IMPORTANT PROCEDURE IS THE PROPER METHOD OF CHANGING AND ALIGNING PUNCHES AND DIES.

▶ **NOTE:** If you are using the optional urethane stripper, please refer to Section 7.13 for additional instructions.

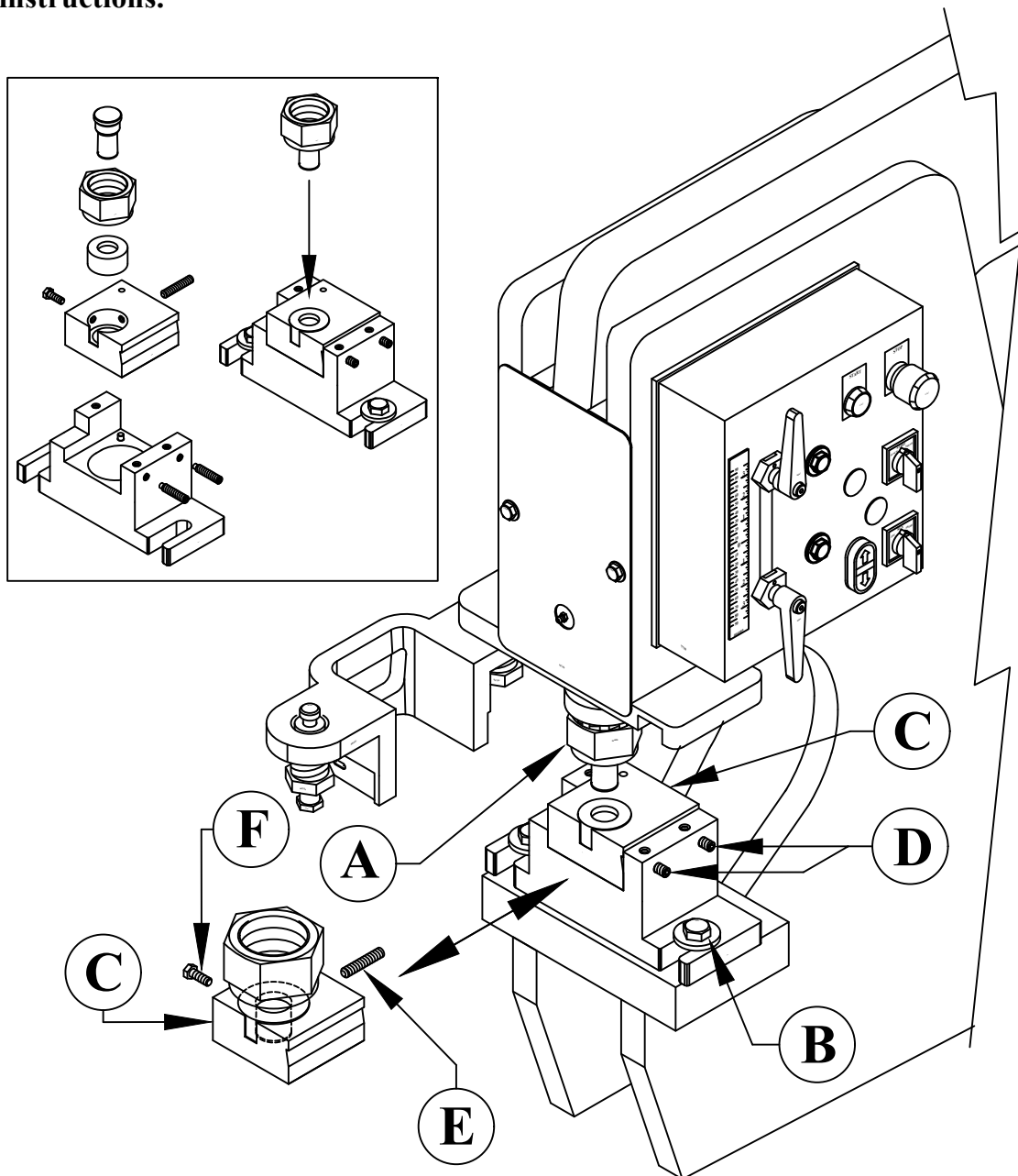

FIGURE 8

A. ALIGNMENT AND REMOVAL OF PUNCHES AND DIES:

- **WARNING:** Failure to properly align punches and dies can cause serious bodily injury to personnel and/or damage to equipment. Please read carefully and understand the following method. It would also be helpful to refer to the safety video on scotchman.com for a visual reference. Also, our YouTube Channel has the safety video as well as many other helpful and informative videos related to this machine.

For parts identification, REFER TO FIGURE 8 ON THE PRECEDING PAGE.

MOVE ALL TOOLING TO THE BACK OF THE TOOL TABLE AND CRANK THE BAR SHEAR HOLD-DOWN TO THE DOWN POSITION WHEN PUNCHING.

- **FAILURE TO MOVE THE ANGLE SHEAR, CHANNEL SHEAR, BRAKES ETC. OUT FROM UNDER THE UPPER ARM CAN RESULT IN POSSIBLE DANGER TO OTHER PERSONNEL AND DAMAGE TO THE TOOLS.**

1. With the machine in the PUNCH position, turn the machine's electrical power off at the disconnect switch.
2. Release the stripper and swing it to the side, out of the way of the punch ram and the punch retaining nut (A).
3. Loosen the die holder bolts (B).
4. Loosen and remove the punch retaining nut (A) and set the punch retaining nut and punch aside.
5. Loosen the two set screws (D) holding the die insert (C). Remove the die insert and loosen the set screw (E) and bolt (F) holding the die in, remove it and set it aside.

- ▶ **NOTE:** The die insert has an alignment dowel pin in it and must be lifted to remove it.

- ⊗ **CAUTION:** IF YOU ARE USING THE OFFSET DIE HOLDER FOR FLANGED PUNCHING, PLEASE SEE SPECIAL INSTRUCTIONS IN SECTION 7.11B.

6. Place the disconnect switch in the ON position and the selector switch in the START position. Power the machine by pressing the green START button.
7. Check to make sure that there are no objects (such as tools) on or under any of the moving parts.
8. Place the selector switch in the SHEAR position and allow the ram to extend.
9. Turn the machine's power off.
10. Clean the die insert cavity of any foreign material.
11. Select the proper punch and die. Make sure that there is proper clearance between the punch and die. For recommended clearances, SEE SECTION 6.1, PARAGRAPH G.
12. Clean both the punch and the die.
13. Insert the proper die in the die insert (C). (If the die has a flat spot in it, align this with the set screw (E) or bolt (F) in the die insert (C). Tighten both firmly.
14. Insert the punch into the punch retaining nut (A), making sure that it seats properly. Place the punch retaining nut assembly on the die insert, with the punch inserted in the die.

► **NOTE:** PLEASE NOTE THAT ALL OF OUR SHAPED PUNCHES, INCLUDING SQUARES, OVALS, HEXAGONS AND SPECIAL ORDER PUNCHES, ARE MANUFACTURED WITH A KEYED ALIGNMENT SYSTEM. THE KEYED SLOT MATES WITH SLOTS IN THE PUNCH RAM TO ALLOW TWO POSITIVE LOCKED POSITIONS FOR THE PUNCH.

15. Place the insert back in the die holder and tighten the set screws.
16. Raise the punch retaining nut and turn it on to the punch ram. (The die holder may have to be moved slightly to align the punch retaining nut to the punch ram.)
17. If you are using keyed punches, manually rotate the punch so that the key seats in the ram before tightening the nut.
18. Tighten the punch retaining nut, using a wrench. Make sure that there is equal clearance on all sides of the punch in the die.

► **NOTE:** WHEN USING A HEAVY DUTY SPLIT-RING RETAINING NUT, AFTER THE NUT HAS BEEN TIGHTENED, TIGHTEN THE BRASS BILLET SET SCREW AGAINST THE THREADS OF THE RAM.

19. Re-tighten the bolts in the die holder.
20. Check to be sure of proper alignment. Realign, if necessary.
21. Return the stripper to the forward position.
22. Place the disconnect switch in the ON position and the selector switch in the START position and power the machine.
23. Place the selector switch in the SHEAR position. To be sure that the clearance is correct, jog the machine several times with the foot switch, without letting the punch come out of the die.
24. Place the selector switch in the PUNCH position.
25. Oil the punch and die before use and every 5 to 10 holes, thereafter. (For lubrication instructions - SEE SECTION 5.1)
26. Punch three to five holes and re-tighten the punch retaining nut.
27. The punch and die alignment should be checked every two to three hours during the punching operations. To do this, bring the punch down so that it enters the die. Turn off the machine. Check and tighten the punch retaining nut, the bolt holding the die and the two bolts holding the die holder. Check for equal clearance between the punch and die. Place the selector switch in the START position and power the machine. Place the selector switch in the SHEAR position and, using the foot switch, jog the machine several times to be sure of proper alignment.

B. CHECK ALL PUNCHING TOOLS FOR TIGHTNESS.

Tools should be checked at the start of each operation and intermittently during the workday. Check the punch retaining nut, die, stripper and die holder. Tools tend to loosen under punching shock. Keep them tight to prevent punch to die contact.

- **NOTE: WHEN PUNCHING LARGE DIAMETER HOLES, OR IN CASES OF HIGH PUNCH SHOCK, IT WILL HELP IF THE STROKE OF THE MACHINE IS ADJUSTED SO THAT THE PUNCH STOPS JUST ABOVE THE PLANE OF THE DIE, APPROXIMATELY FIFTEEN THOUSANDTHS OF AN INCH (.3MM).**

C. DO NOT PUNCH ANYTHING THICKER THAN THE PUNCH DIAMETER.

This "rule of thumb" can be extended, but the punch supplier or Scotchman should be consulted first, (i.e. do not punch plate thicker than 1/2 inch with a 1/2 inch diameter punch). This rule of thumb applies to mild steel and must be reduced when punching alloy steels.

Contact the factory or your local dealer before attempting to punch any type of alloys.

D. LUBRICATE THE PUNCH AND DIE.

This will hold stripping forces to a minimum and greatly extend punch life. Lubrication must be applied after every 5 to 10 holes.

E. PUNCH FULL AND COMPLETE HOLES. DO NOT PUNCH PARTIAL HOLES.

The side thrust encountered in punching a partial hole can force the punch over against the die and result in punch or die breakage. This may result in serious bodily injury!

F. MAINTAIN SUFFICIENT MATERIAL BETWEEN THE PUNCHED HOLE AND THE EDGE OF THE WORKPIECE.

The edge of the punch should be clear of the edge of the workpiece by a distance equal to the thickness of the material. Any edge distance less than this will result in a deformed workpiece.

G. STAY WITHIN RATED PUNCHING CAPACITIES.

Your 9012-24M Ironworker is designed to operate in mild steel. Within conservative limits, it can also operate in medium carbon annealed steel and some forms of abrasion resistant steels. Conditions of high shock can be encountered when punching alloyed steels and, accordingly, the machine rating must be reduced.

THE MAXIMUM THICKNESS THAT CAN BE PUNCHED IS 1 INCH (25MM) MILD STEEL.

Punch to die clearance depends on material thickness.

In mild steels, material thicknesses of 1/4 inch through 5/8 inch should have a total punch to die clearance of 1/32 inch. (Punch diameter + 1/32" = Die diameter.) 3/4 inch (19mm) thick mild steel should have a minimum of 1/16 inch clearance. (Punch diameter + 1/16" = die diameter.)

In thin materials, the recommended punch to die clearance is 1/10 of the material thickness.

We do not recommend less than 1/64 inch total clearance, due to working clearances necessary in the punch ram and the punch bushing.

For capacities, REFER TO THE PUNCH TONNAGE CHART IN FIGURE 9 BELOW.

TONS REQUIRED PER HOLE TO PUNCH MILD STEEL HAVING 65,000 PSI TENSILE STRENGTH																
HOLE DIAMETER		1/8	3/16	1/4	5/16	3/8	7/16	1/2	9/16	5/8	11/16	3/4	13/16	7/8	15/16	1
		.125	.1875	.250	.3125	.375	.4375	.500	.5625	.625	.6875	.750	.8125	.875	.9375	1.00
METAL GAUGE	THICKNESS INCHES	P R E S S U R E I N T O N S														
28	.015	.2	.2	.3	.4	.4	.5	.6	.7	.7	.8	.9	1.0	1.1	1.2	1.3
26	.018	.2	.3	.4	.4	.5	.6	.7	.8	.9	1.0	1.1	1.1	1.2	1.3	1.4
24	.024	.2	.4	.5	.6	.7	.8	.9	1.1	1.2	1.3	1.4	1.5	1.6	1.8	1.9
22	.030	.3	.4	.6	.7	.9	1.0	1.2	1.3	1.5	1.6	1.8	1.9	2.1	2.2	2.4
20	.036	.4	.5	.7	.9	1.1	1.2	1.4	1.6	1.8	1.9	2.1	2.3	2.5	2.6	2.8
18	.048	.5	.7	.9	1.2	1.4	1.6	1.9	2.1	2.4	2.6	2.8	3.1	3.3	3.5	3.8
16	.060	.6	.9	1.2	1.5	1.8	2.1	2.3	2.6	2.9	3.2	3.5	3.8	4.1	4.4	4.7
14	.075	.7	1.1	1.5	1.8	2.2	2.6	2.9	3.3	3.7	4.0	4.4	4.8	5.1	5.5	5.9
12	.105	1.0	1.5	2.1	2.6	3.1	3.6	4.1	4.6	5.1	5.7	6.2	6.7	7.2	7.7	8.2
10	.135	1.3	2.0	2.6	3.3	4.0	4.6	5.3	5.9	6.6	7.3	7.9	8.6	9.2	9.9	10.6
5/32	.157	-	2.3	3.1	3.8	4.6	5.4	6.1	6.9	7.7	8.4	9.2	10.0	10.7	11.5	12.3
3/16	.188	-	2.8	3.7	4.6	5.5	6.4	7.4	8.3	9.2	10.1	11.0	12.0	12.9	13.8	14.8
1/4	.250	-	-	4.9	6.1	7.4	8.6	9.8	11.1	12.3	13.5	14.7	16.0	17.2	18.4	19.7
3/8	.375	-	-	-	-	11.1	12.8	14.8	16.5	18.5	20.2	22.1	23.8	25.8	27.5	29.5
1/2	.500	-	-	-	-	-	-	19.7	22.0	24.6	26.9	29.5	31.8	34.4	36.8	39.4
5/8	.625	-	-	-	-	-	-	-	-	30.8	33.7	36.9	39.9	43.0	46.0	49.2
3/4	.750	-	-	-	-	-	-	-	-	-	-	44.3	47.7	51.7	55.2	59.0
1	1.00	-	-	-	-	-	-	-	-	-	-	-	-	-	-	80.0

FIGURE 9

6.1A STRIPPER ADJUSTMENT

CAUTION: TO PREVENT PUNCH BREAKAGE ON THE RETURN STROKE, THE STRIPPER MUST BE ADJUSTED SO THAT THE BOTTOM OF THE STRIPPER IS PARALLEL WITH THE MATERIAL BEING PUNCHED.

REFER TO FIGURE 10 BELOW.

TO ADJUST THE STRIPPER:

- 1. The height of the stripper is adjusted using the adjustment bolts (A & B).**
- 2. The stripper is opened by pushing up on item (C) and swinging it out toward the front of the machine.**
- 3. If you are punching light material or pieces too small to contact both sides of the stripper, install the plate (D) on the bottom of the stripper.**
- 4. For maximum visibility and safety, always adjust the stripper down as close to the material as possible.**

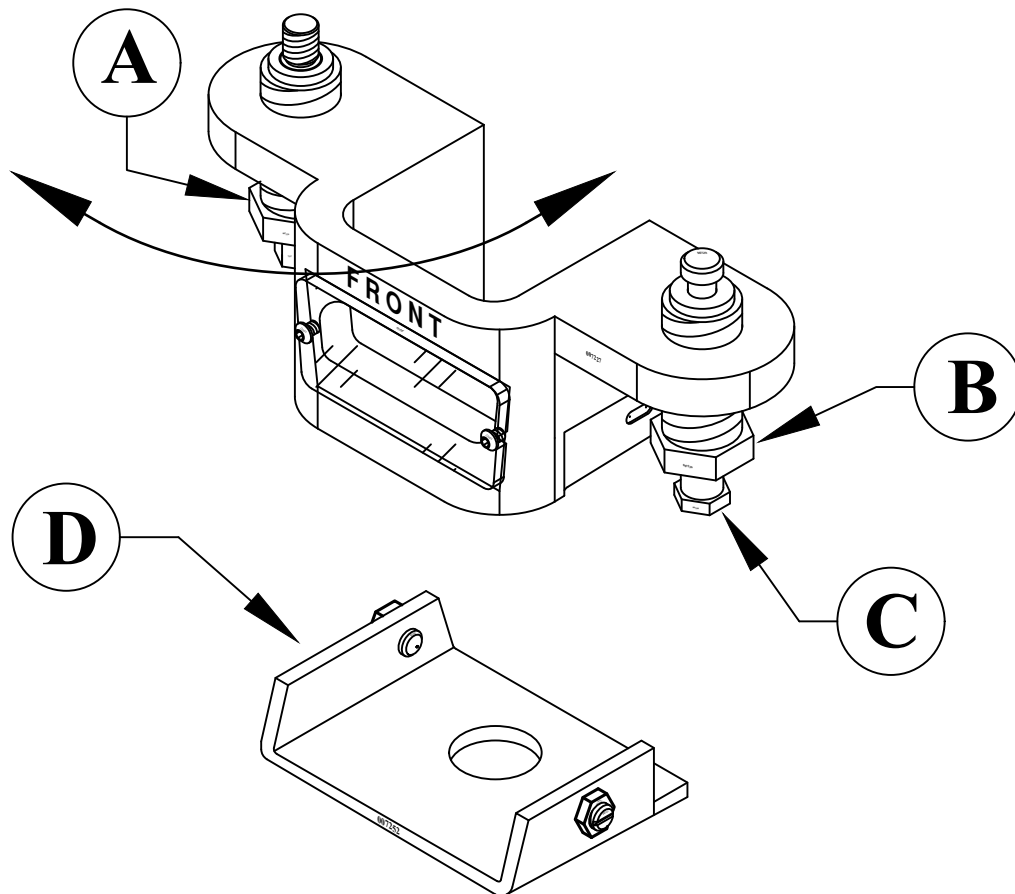

FIGURE 10

6.2 BAR SHEAR OPERATION

⊗ CAUTION: ANY TIME THAT THE SHEAR SECTION IS NOT IN USE, CRANK THE HOLD-DOWN DEVICE TO ITS FULL DOWN POSITION.

Before using the bar shear, make sure that all tooling has been moved out from under the upper arm and that the punch and die have been removed from the punch station. When using the Bar Shear on your Scotchman Ironworker, ALWAYS use the hold-down device.

➡ NEVER put any part of your body between the hold-down and the material to be sheared.

A clearance of 1/8 inch (3mm) between the hold-down and material to be sheared is acceptable.

The maximum tonnage available on the bar shear is to the left, or closest to the pivot point. For applications that do not require the maximum tonnage, move the material to the right, for minimal distortion on the drop piece.

Do not attempt to shear pieces that are too short for the hold-down to grip as this will cause the material to kick-up and will result in a poor quality cut and possible damage to the machine.

THE BASIC METHOD OF OPERATING THE BAR SHEAR CONSISTS OF SIX STEPS:

- 1. Place the selector switch in the START position and power the machine.**
- 2. Place the selector switch in the SHEAR position.**
- 3. Place the material to be sheared between the shear blades.**
- 4. Crank the hold-down device down to the material being sheared. This prevents kick-up of the material, which could cause injury to the operator and damage to the machine.**
- 5. Keep your hands clear from all moving parts.**
- 6. Depress the foot switch. Lubricate the blades every 10 to 15 cuts.**

IN ADDITION TO THE SIX BASIC STEPS OF OPERATION, THE OPERATOR SHOULD ALSO BE FAMILIAR WITH THE FOLLOWING:

A. MAINTAIN PROPER BLADE CLEARANCE.

The quality of the cut is an immediate indication of the condition of the Shear Blades, the amount of clearance between the blades or the amount of "spring-back" in the Shear Arm.

The Shear Blades are symmetrical and can be rotated to expose four (4) cutting edges.

For recommended clearances, SEE FIGURE 12 ON PAGE 35.

B. ALL CUTS SHOULD BE MADE AS FAR FROM THE ARM PIVOT AS POWER WILL PERMIT.

The Shear Blades should contact the workpiece as flat as possible, to reduce to a minimum the amount of "curl" on the cut-off piece. More shearing force is obtained as the operator moves the workpiece toward the left. The machine is designed to shear mild steel rated on 65,000 tensile.

The maximum capacity of the bar shear is 1 x 8 inch (25 x 203mm) mild steel.

6.2A SHEAR ARM ADJUSTMENT (S/N 21601 & UP)

SEE FIGURE 11 ON THE FOLLOWING PAGE.

Adjustment on the shear arm is maintained on the front (operator's) side by the pressure plate (A) and on the rear by the rub blocks (I & J). Your ironworker may have only one set of rub blocks (two are shown) but the procedure is the same. The cylinder cover shroud must be removed to gain visual access.

USE THE FOLLOWING STEPS TO ADJUST THE SHEAR ARM.

- 1. Before making these adjustments, loosen the lower blade bolts and back-up screws and back the lower blade away from the upper blade. After making these adjustments, reset the blades following the instructions in SECTION 6.2B.**
- 2. Loosen the six adjusting screws (H) for each of the rub blocks (I) and remove the rub blocks by taking out the three mounting screws (G). (If excessive concave wear is noted on the rub blocks, they can be turned and the back surface used.) Set the pressure plate adjustment before resetting the rub blocks.**
- 3. For the pressure plate adjustment, loosen the lock nuts (B) on the four adjusting screws that engage the pressure plate (A).**
- 4. Tighten all four adjusting screws on the pressure plate so that they are "snug" and will force the shear arm solidly against the rear frame. Tighten the adjusting screws to 30 ft-lbs (41 Nm). Excessive tightening of these screws will only increase wear.**
- 5. Replace the rub blocks (I). With the shear arm in the down position, tighten the bottom adjusting screws (H) until the rub blocks come in contact with the shear arm rub blocks (J). Raise the arm about half way and adjust the middle two adjusting screws (H) until the rub blocks make contact. Then, raise the arm completely and adjust the top two screws. (Once again, excessive tightening will cause unnecessary wear.) Check to be sure that the rub blocks (I) are in contact with the shear arm rub blocks (J) throughout the full stroke.**
- 6. Tighten the lock nuts on the pressure plate adjusting screws (B) and tighten the mounting screws (G) on the rub blocks.**
- 7. Reset the shear blade adjustment. SEE SECTION 6.2B.**

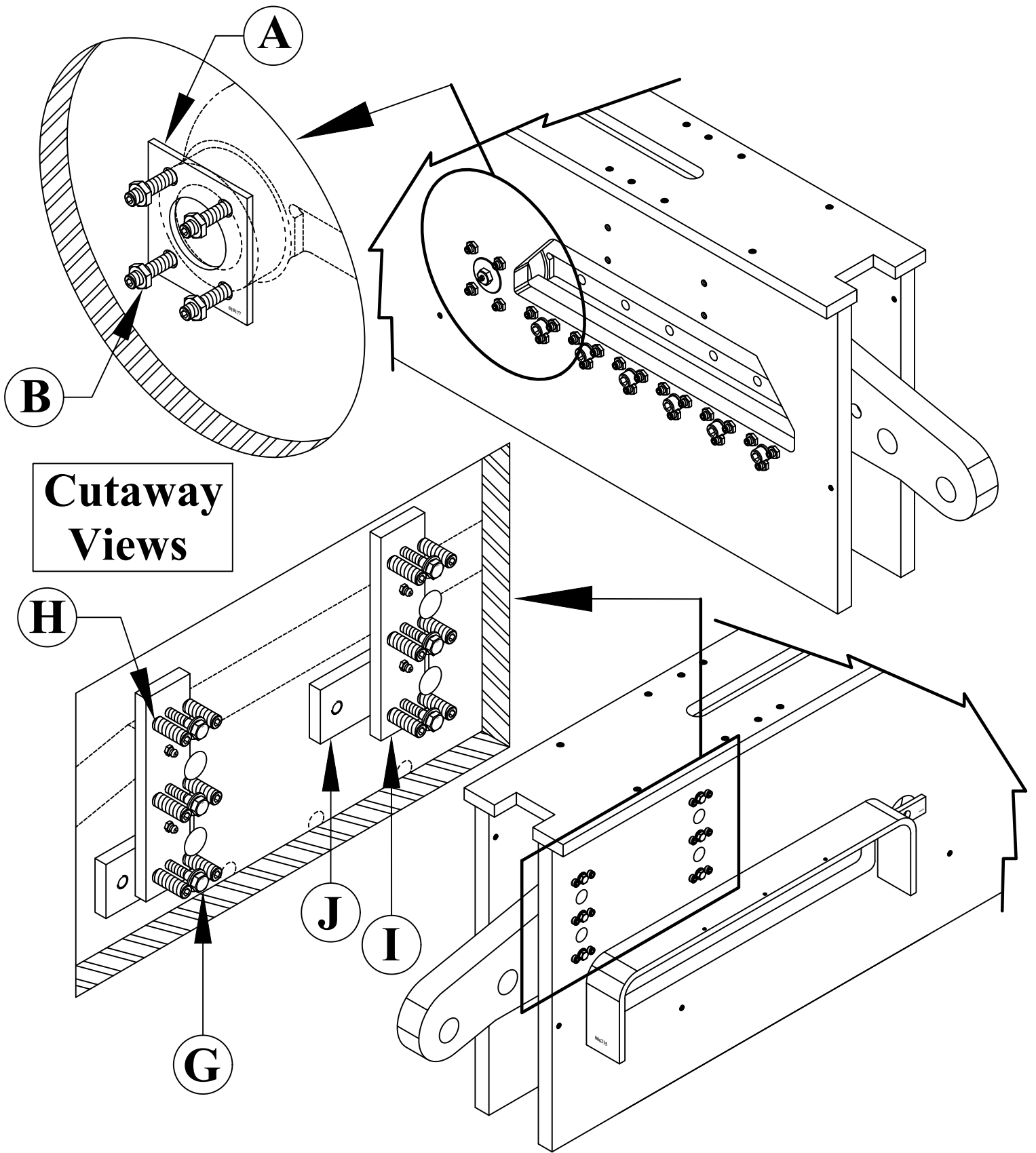

FIGURE 11

6.2B BAR SHEAR BLADE ADJUSTMENT PROCEDURE

(SERIAL #'S 21601M & UP)

SEE FIGURE 12 ON THE FOLLOWING PAGE.

1. Place the selector switch in the SHEAR position and allow the arms to raise completely.
2. Crank the hold-down device all the way up and remove the shear table (B).
3. To remove the shear table, loosen the jam nut (F) on the bolts (C) and remove the bolt. Remove the lower blade bolts (E) and washers (E1) and back the adjustment screws (D) out.
4. Remove the lower blade.
5. Power the machine and place the selector switch in the PUNCH position. Allow the arm to travel to its full down position. Turn the power off.
6. Rotate or replace the shear blade on the arm.
7. Rotate or replace the lower blade and start the socket head retaining bolts (E).
8. Place a shim with the desired clearance between the upper and lower blades.
9. Adjust the lower blade to the top blade, with the upper adjusting screws (D), about 1/8 of a turn past resistance.
10. Tighten the bolts (E) to 1/4 a turn past resistance.
11. Adjust the lower adjusting screws (D) up to the blade and then, tighten all of the bolts, starting with the blade bolts (E) and then, the adjusting screws (D).

CAUTION: THE BLADES MUST BE ADJUSTED PARALLEL TO EACH OTHER, vertically or with the cutting edge of the lower blade at a slight cant towards the upper blade.

12. Power the machine and place the selector switch in the SHEAR position. With the foot pedal, cycle the shear down slowly, watching the blade engagement. Make sure that the blades do not contact each other.
13. Replace the shear table (B). If needed, the shear table can be adjusted to match the lower blade. The table is adjusted with the four screws (G).
14. If the machine is being used to shear maximum capacities, we recommend increasing the clearance. A clearance of five to seven percent of the material thickness is recommended. Please use the chart at the upper right on the next page as a guide.

QUICK GUIDE TO CHANGING BAR SHEAR BLADES

- 1st - remove lower blade
- 2nd - change upper blade
- 3rd - start bolts (E) in lower blade
- 4th - place shim between blades
- 5th - adjust upper set screws 1/8 turn past resistance
- 6th - tighten blade bolts 1/4 turn past resistance
- 7th - adjust lower set screws up to lower blade
- 8th - final tighten: blade bolts, then set screws

MAKE SURE BLADES HAVE PROPER CLEARANCE AND ARE PARALLEL: LOWER BLADE MAY HAVE A SLIGHT CANT AS SHOWN

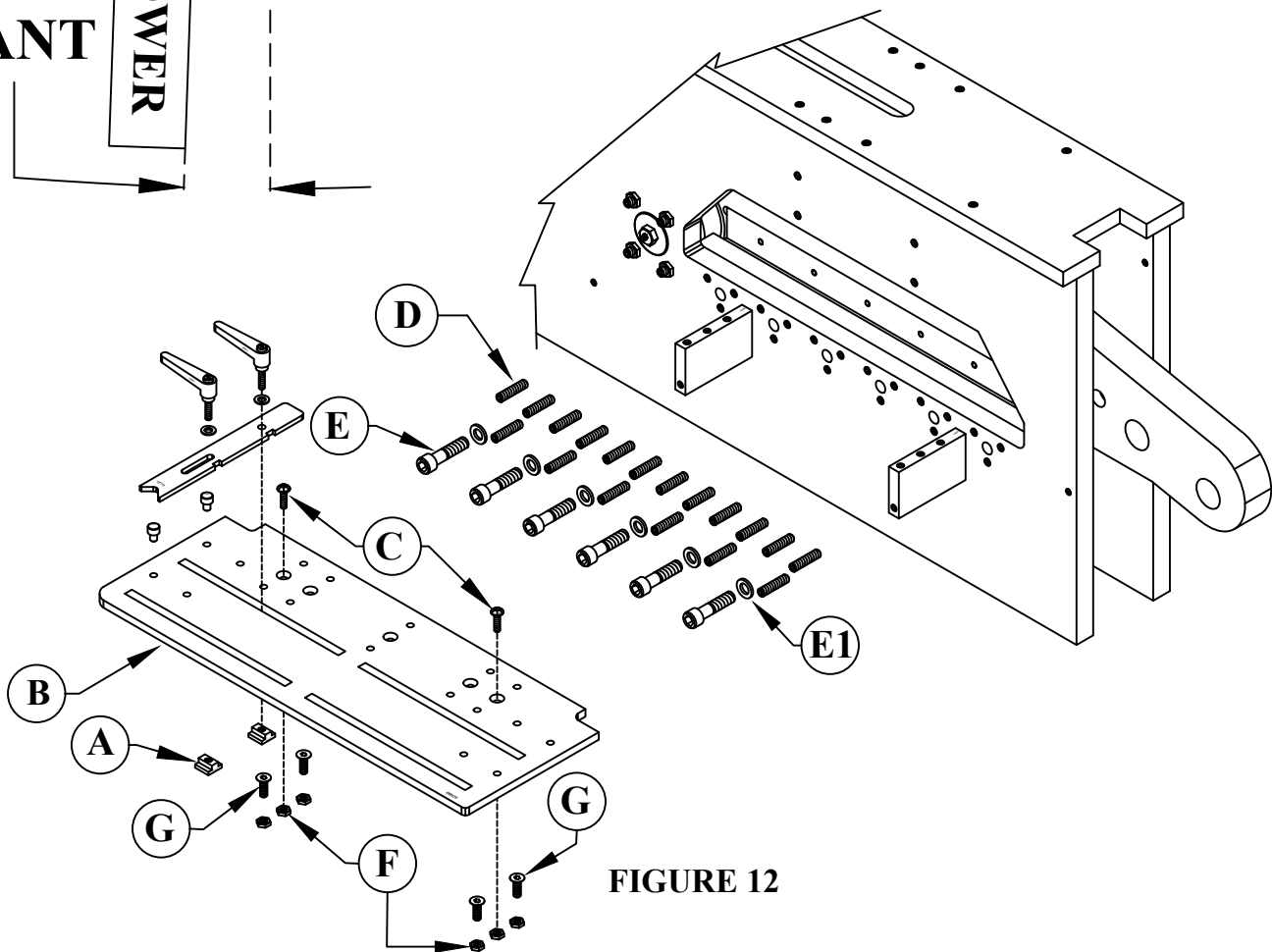
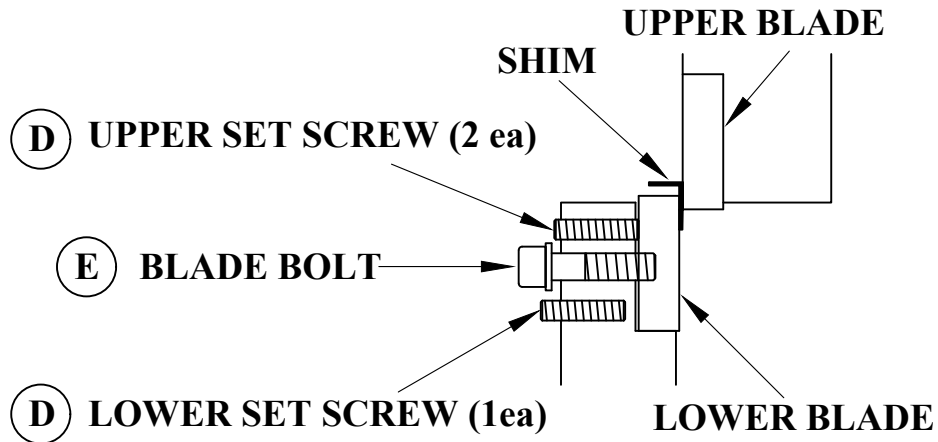
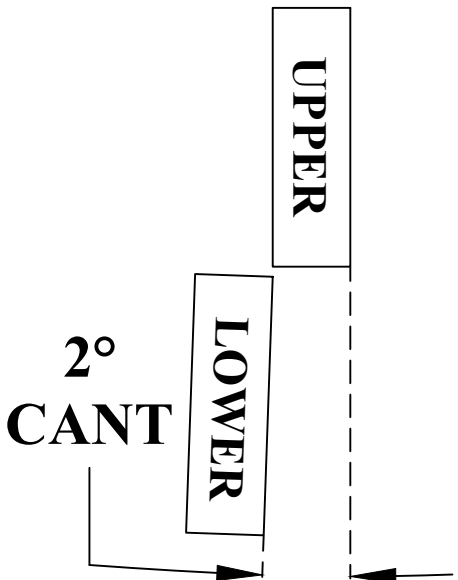
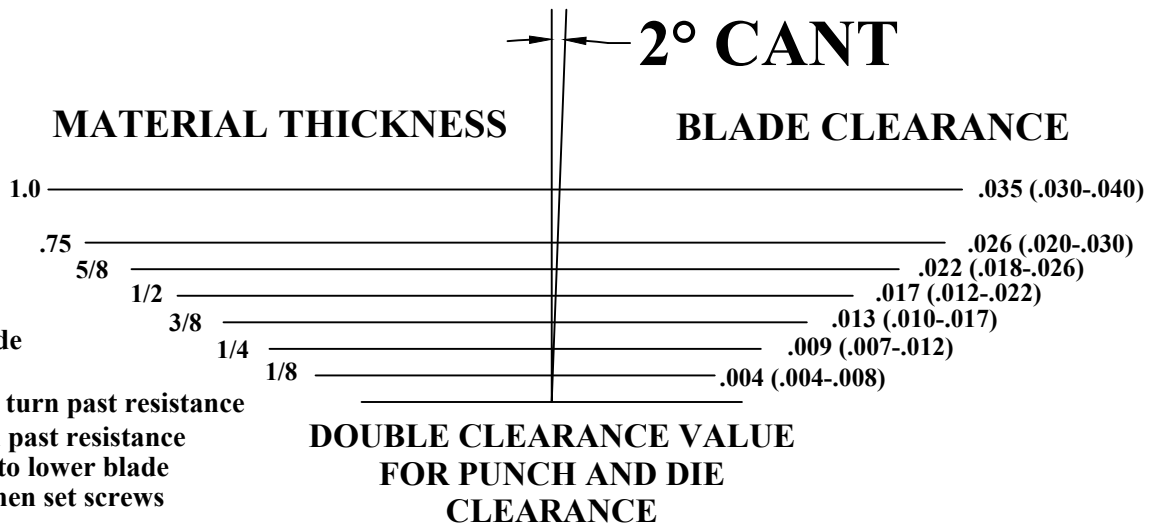

FIGURE 12

7.0 OPTIONAL TOOL OPERATION

⊗ **CAUTION: MOVE ALL TOOLS OUT FROM UNDER THE UPPER ARM WHEN THEY ARE NOT IN USE.**

NOTE: If a tool ever jams or gets stuck - REMOVE THE TOOL FROM THE MACHINE BEFORE ATTEMPTING TO FREE IT.

When using the tool station, crank the bar shear hold-down device completely down and remove the punch and die.

As with all functions on this machine, SAFETY GLASSES ARE REQUIRED when using optional tools of any type.

Each self contained tool has its own stroke and tonnage requirements. This section will cover the operation and location of each tool.

At the beginning of the section, there is a graphical illustration of the available tonnage at locations along the Upper Arm. SEE FIGURE 13 ON THE FOLLOWING PAGE.

This graph will be helpful in setting up various Scotchman or custom tooling.

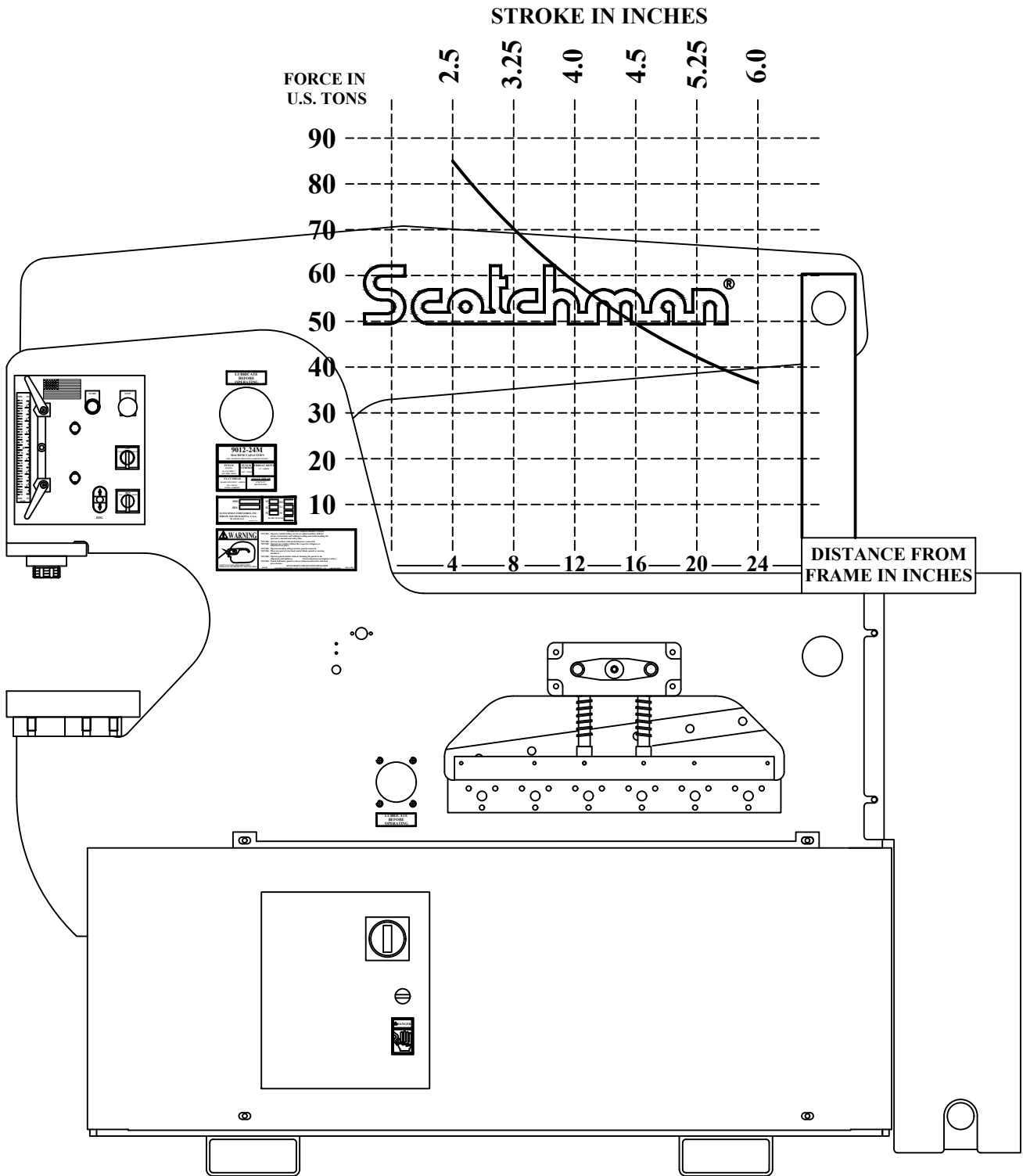

FIGURE 13

7.1 6 X 6 ANGLE SHEAR

The 6 x 6 angle shear is a component tool designed to shear angle iron. It installs in the tool station on this machine and has a maximum capacity of 6 x 6 x 3/8 or 5 x 5 x 1/2 inch (152 x 152 x 10 or 127 x 127 x 12mm) mild steel angle iron. The selector switch must be in the SHEAR position to operate this tool.

7.1A 6 X 6 ANGLE SHEAR INSTALLATION

SEE FIGURE 14 ON THE FOLLOWING PAGE.

The 6 x 6 Angle shear mounts in the tool station under the upper arm.

1. Before mounting the tool under the arm, remove the upper blade and install the return springs (A).
2. The selector switch must be in the SHEAR position and the arm up.
3. Slide the tool under the arm, as close to the machine's frame as possible.
4. The tool is held in place with the finger clamps (B) provided.
5. Care must be taken to align the slug slot in the angle shear with the slot in the tool table and the pressure block squarely under the power arm.
6. The upper stroke of the machine should be set so that the upper blade raises high enough to slide the workpiece freely through the unit. The lower stroke should be set so that the upper blade point enters the lower blades approximately 1/8 inch (3mm).

7.1B 6 X 6 ANGLE SHEAR OPERATION

Oil must be applied to the blades before the first cut is made and every 10 to 15 cuts, thereafter.

Grease the slider block between the upper arm and the tool every two hours of operation. A set of lower blade shims are shipped with each unit. These are to be installed between the lower blades and the side plate when shearing lighter angle (up to 5/16 of an inch (8mm) thick). If a burr develops when shearing very light gauge angle, the clearance should be reduced further by adding additional shim stock. All shims must be removed when shearing angle thicker than 5/16 of an inch (8mm).

When cutting angle iron with legs of unequal length, a special upper angle shear blade is necessary.

- ⊕ Do not attempt to cut unequal leg angle iron with the standard blade. It only takes one cut to damage the tool.

For available blades, SEE THE TOOLING PARTS MANUAL.

- ▶ **NOTE:** Always shear unequal leg angle with the long leg to the right. If the upper blade does not contact both legs of the angle at the same time at the beginning of the cut, the shear will be damaged.

NOTE: If tool ever jams or gets stuck - REMOVE THE TOOL FROM THE MACHINE BEFORE ATTEMPTING TO FREE IT.

CAUTION: DO NOT ATTEMPT TO FREE IT BY HAND!! USE A PRY BAR OR SIMILAR DEVICE. REPLACE THE BLADES OR INSTALL SHIMS, DEPENDING ON WHAT CAUSED THE JAM. REMOVE THE TOOL WHEN IT IS NOT IN USE.

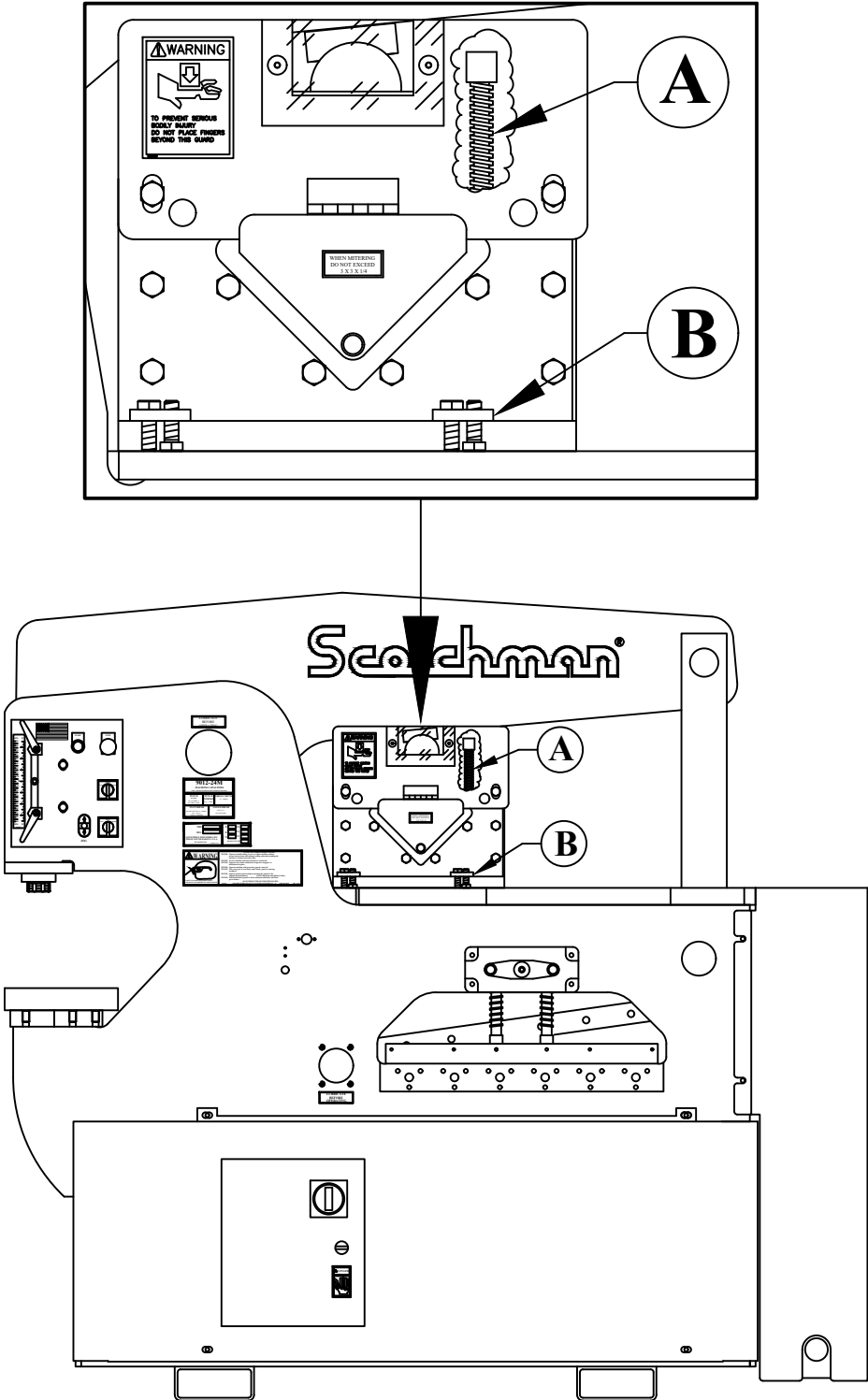

FIGURE 14

7.2 ROD SHEAR

The rod shear is a component tool designed to shear sections of solid round and square stock. It has 9 round cavities that range from 1/4 to 1-1/4 inches (6 to 30mm) and one square cavity that has the capacity 1/4 to 1 inch (6 to 25mm). The selector switch must be in the SHEAR position to operate this tool.

7.2A ROD SHEAR INSTALLATION

SEE FIGURE 15 ON THE FOLLOWING PAGE.

The rod shear mounts in the tool station under the upper arm and is held in place with finger clamps. Since the rod shear requires a short stroke (approximately 1/2 inch (12mm) and has no slug, it can be operated at any practical location under the upper arm.

To prevent damage to the tool, the stroke of the machine must be set when using the rod shear.

Set the upstroke of the machine so that the workpiece easily slides through the tool.

Set the down stroke so that the cut can be made with a minimum amount of stroke.

7.2B ROD SHEAR OPERATION

Oil the blades before starting and every 10 to 15 cuts, thereafter.

Grease the slider block between the upper arm and the tool every two hours of operation.

On all round sizes, select the proper cavity for the size being sheared.

In the square cavity there is a kick-up bolt adjustment.

Adjust this bolt so that the workpiece will just feed under the bolt and remains horizontal to the shear.

⊗ **CAUTION: WHEN SHEARING SHORT PIECES OR NIPPING THE ENDS OF THE ROD, CARE SHOULD BE TAKEN SO THAT THE SLUGS DO NOT BUILD UP IN THE DROP-OFF SIDE IF SLUGS BUILD UP IN THE DROP-OFF SIDE, THERE IS A POSSIBILITY OF INJURY TO OTHER PERSONNEL AND DAMAGE TO THE TOOL. REMOVE THE ROD SHEAR WHEN IT IS NOT IN USE.**

NOTE: If tool ever jams or gets stuck - REMOVE THE TOOL FROM THE MACHINE BEFORE ATTEMPTING TO FREE IT.

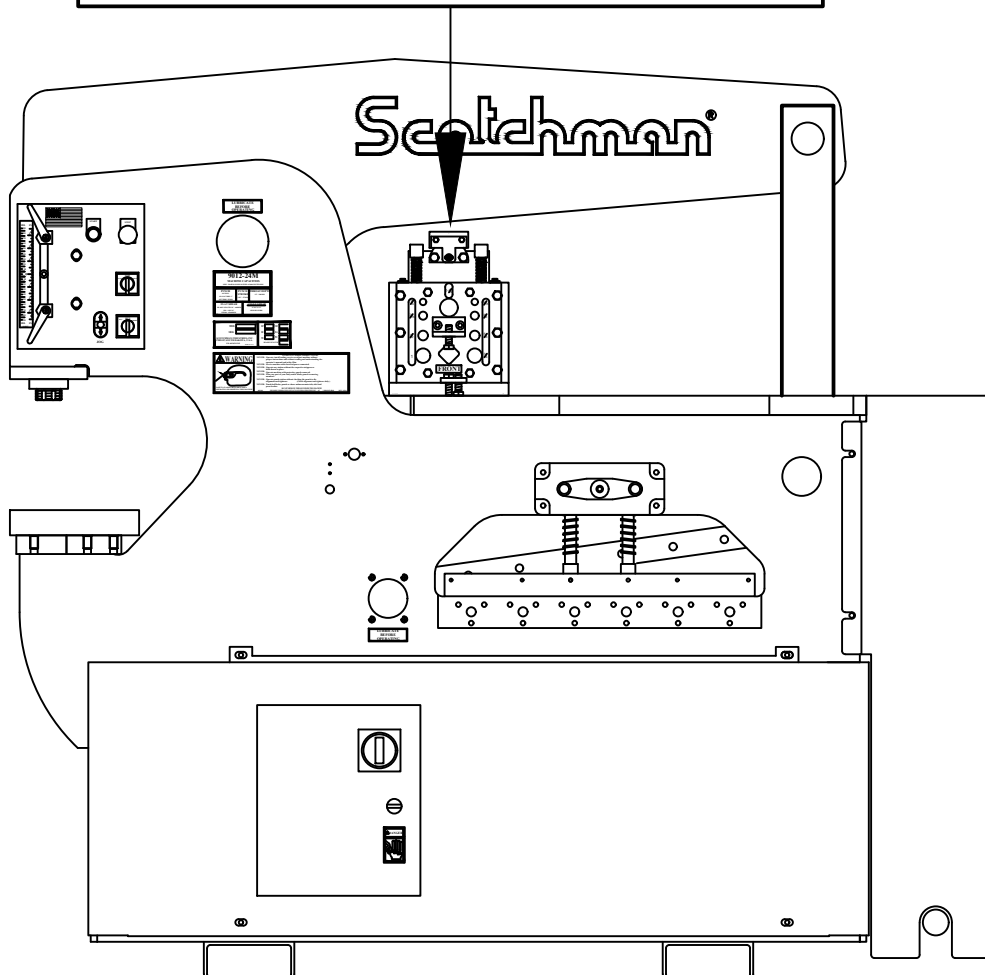
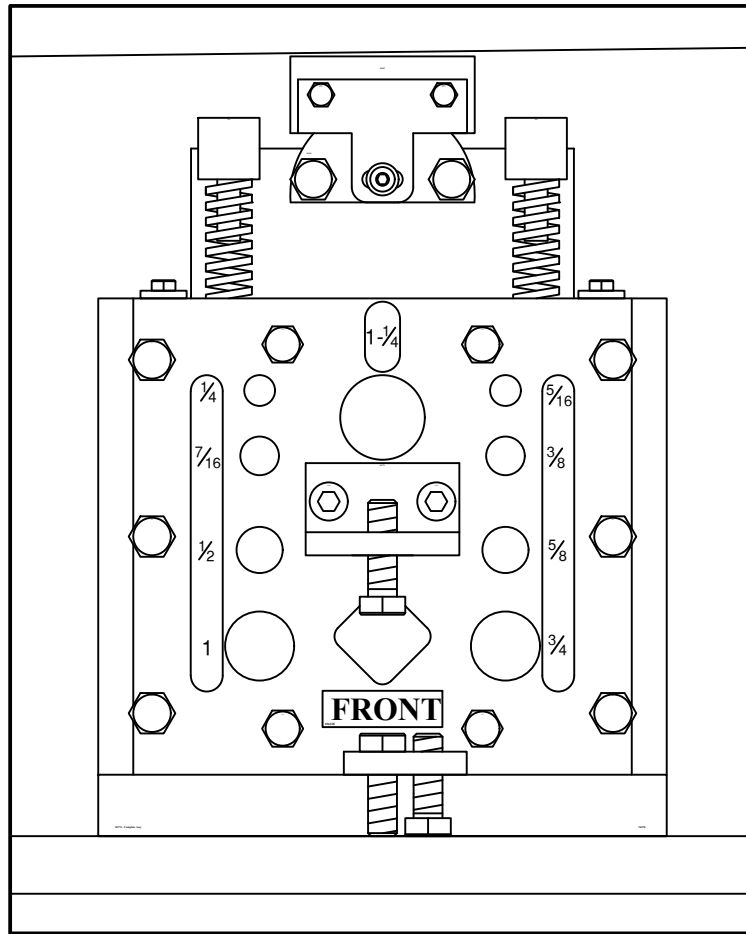

FIGURE 15

7.3 6 X 6 NINETY DEGREE NOTCHER

The 6 x 6 ninety degree notcher is a component tool designed to cut 90 degree Vee notches in angle and flat stock. It has a maximum capacity of 5/16 of an inch (8mm) thickness mild steel.

7.3A 6 X 6 NINETY DEGREE NOTCHER INSTALLATION

SEE FIGURE 16 ON THE FOLLOWING PAGE.

The 6 x 6 ninety degree notcher can be mounted either under the upper arm on the tool table or in the punch station.

When the notcher is mounted on the tool table, the selector switch must be in the SHEAR position.

When the notcher is in the punch station, the selector switch must be in the PUNCH position.

⊗ **CAUTION: IN EITHER STATION, CARE MUST BE TAKEN TO SET THE UPPER AND LOWER STROKE CONTROLS ON THE MACHINE. FAILURE TO SET THE STROKE CONTROLS WILL RESULT IN DAMAGE TO THE TOOL AND POSSIBLE INJURY TO THE OPERATOR.**

The upper stroke should be set so that the pusher assembly is held in place by the spring tension of the tool. The lower stroke must be set so that the upper blade just passes the lower blades at the point of the vee by no more than 1/16 of an inch (1.5mm).

To install the notcher under the upper arm, the tool should be mounted as close to the frame as possible and anchored with the bolts and thick washers (A) provided. The pusher (B) and beam block (C) should be installed per the dimensions in FIGURE 16.

To mount the notcher in the punch station, first remove the die holder, stripper and punch. Mount the short punch pusher (G) with the standard jam nut. Mount the notcher to the punch table with the front of the notcher so its about even with the front edge of the punch table. SEE FIGURE 16. The notcher mounts to the punch table with the heavy washers and bolts (D) provided. The Punch Pusher (G) and the Notcher Pusher (E) should align as shown, with the punch pusher toward the front of the notcher pusher.

7.3B 6 X 6 NINETY DEGREE NOTCHER OPERATION

Lubricate the blades before starting and every 10 to 15 cuts, thereafter. Lubricate the pusher bars (B & C) every two hours of operation. Do not attempt to shear material thicker than 5/16 OF AN INCH (8mm) and never side load the notcher. The slug must be removed after every cut. Remove the slug with a magnetic probe or tongs.

➡ **DO NOT REMOVE THE SLUGS BY HAND.**

NOTE: If tool ever jams or gets stuck - REMOVE THE TOOL FROM THE MACHINE BEFORE ATTEMPTING TO FREE IT.

➡ **ALWAYS REMOVE THE NOTCHER WHEN IT IS NOT IN USE.**

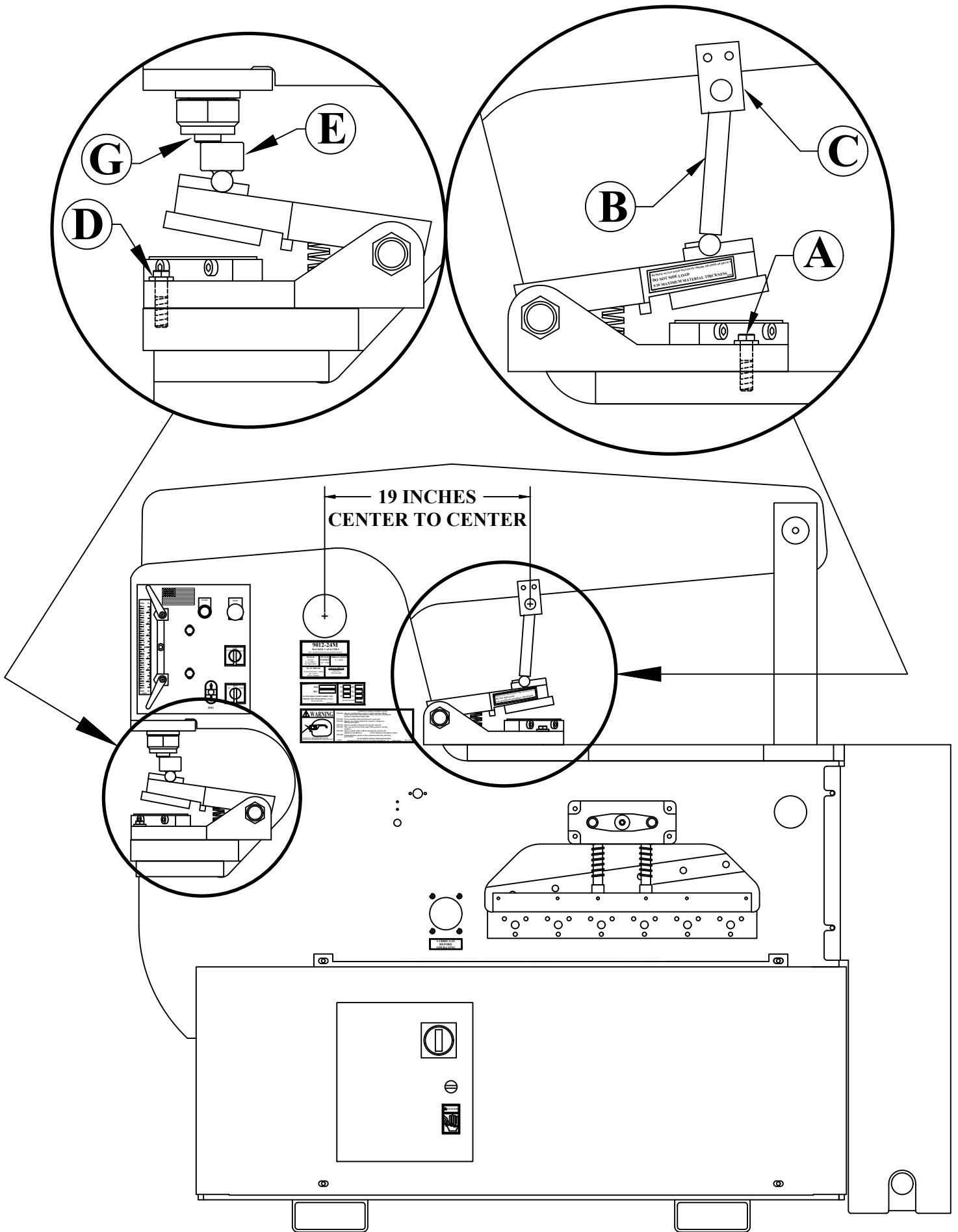

FIGURE 16

7.3C BLADE REPLACEMENT

The lower blades are symmetrical and can be rotated to expose four cutting edges.
The upper blades have two cutting edges.

TO ROTATE OR REPLACE THE BLADES, USE THE FOLLOWING STEPS:

⊠ CAUTION: THE UPPER CASTING OF THE NOTCHER IS HEAVY ENOUGH TO CAUSE INJURY IF DROPPED. USE CARE WHEN HANDLING THIS TOOL.

- 1. Remove the return springs from the unit.**
- 2. Rotate or replace the upper blade and snug bolts only, to allow further adjustments.**
- 3. Rotate or replace the lower blades.**
- 4. Lower the upper blade down until it just passes the lower blade, approximately 1/16 of an inch (1.5mm).**
- 5. Adjust the upper blade until the point almost touches the lower blades.**
- 6. Center the rear of the upper blade with the rear of the lower blades. There should be a clearance of approximately .005 of an inch (.12mm) on each side.**
- 7. Tighten the upper blade bolts. To check blade alignment, raise and lower the upper casting several times, by hand. After alignment, tighten the back up set screws, making sure that the upper blade does not move.**

7.4 RECTANGLE NOTCHER

The Rectangle Notcher is a component tool designed to make a 2 inch (50mm) wide notch in angle iron or flat stock.

7.4A RECTANGLE NOTCHER INSTALLATION

SEE FIGURE 17 ON THE FOLLOWING PAGE.

The Rectangle Notcher mounts only in the punch station on this model. The selector switch must be in the PUNCH position to operate this tool.

TO MOUNT THE NOTCHER, remove the die holder and stripper. Mount the notcher so that the punch ram lines up over the pressure block on the tool. With the two M16 bolts used in the punch station, bolt the tool to the punch bolster using the bolt holes on the right side of the tool.

7.4B RECTANGLE NOTCHER OPERATION

⊗ **CAUTION:** BEFORE OPERATING THIS TOOL, THE DOWNSTROKE OF THE MACHINE MUST BE SET SO THAT THE FRONT OF THE TOP BLADE JUST PASSES THE LOWER BLADES, APPROXIMATELY 1/8 OF AN INCH (1.5MM). FAILURE TO SET THE STROKE WILL RESULT IN DAMAGE TO THE TOOL AND POSSIBLE INJURY TO THE OPERATOR. LUBRICATE THE BLADES BEFORE THE FIRST CUT AND EVERY 10-15 CUTS, THEREAFTER. THE MAXIMUM MATERIAL THICKNESS THAT CAN BE SHEARED IS 3/8 OF AN INCH (9.5MM).

➔ **ALWAYS REMOVE THIS TOOL WHEN IT IS NOT IN USE.**

NOTE: If tool ever jams or gets stuck - REMOVE THE TOOL FROM THE MACHINE BEFORE ATTEMPTING TO FREE IT.

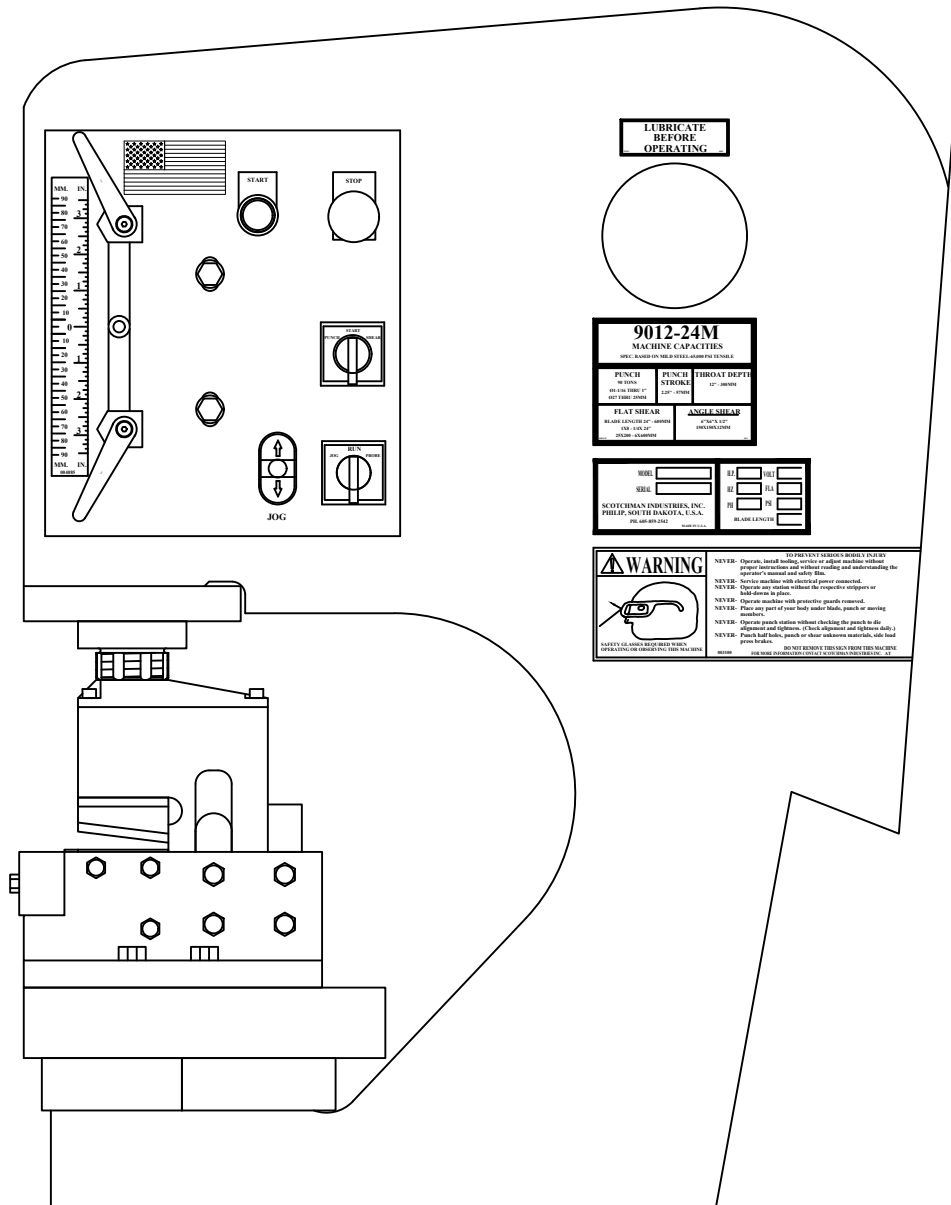

FIGURE 17

7.5 12 AND 24 INCH BRAKES

Brakes are component tools designed to bend and form mild steel. They are shipped standard with dies to accommodate material up to 1/4 of an inch (6mm) thickness. The selector switch must be in the SHEAR position to operate these tools.

7.5A 12 AND 24 INCH BRAKE INSTALLATION

SEE FIGURE 18 BELOW.

There are two lengths of brakes available for this model: 12 and 24 inch. The brakes mount under the upper arm in the tool station and are held down with the finger clamps provided. Mount the 12 inch brake as close to the frame as possible, for maximum tonnage available. There is a press brake tonnage chart that will be helpful when using a brake on this machine. SEE FIGURE 19 ON THE FOLLOWING PAGE. On this model, the twelve inch brake has 40 tons and the twenty four inch has 30 tons.

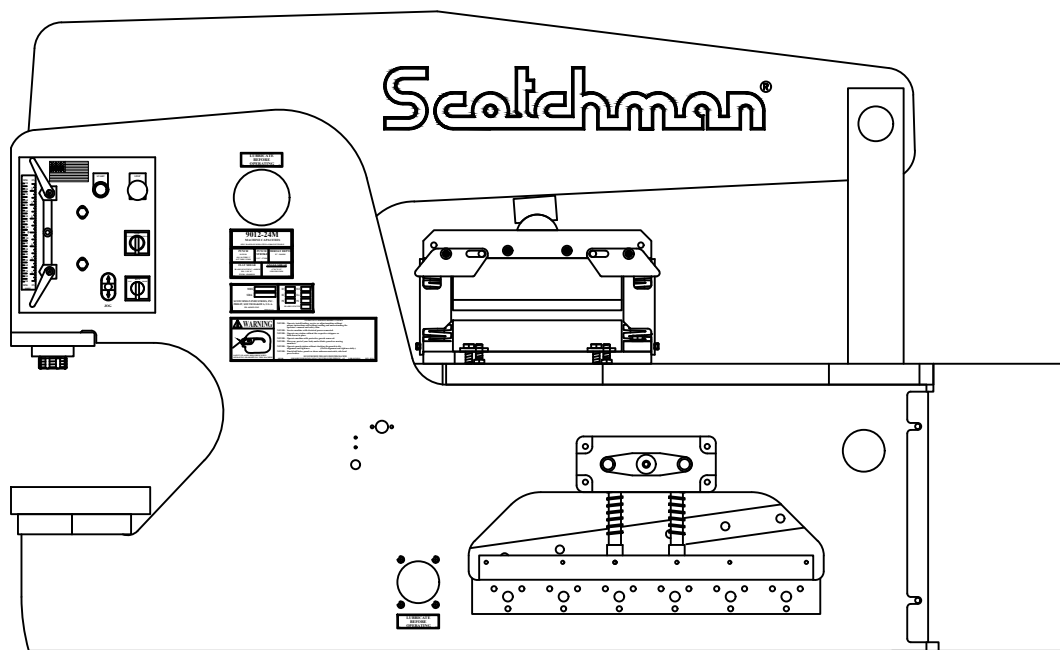

FIGURE 18

7.5B 12 AND 24 INCH BRAKE OPERATION

➡ NEVER PUT YOUR HANDS INTO OR AROUND A BRAKE WHILE IT IS IN OPERATION.

Grease the slider block between the upper arm and the tool every two hours of operation. Hold short pieces with tongs or a similar device. In using the brake, it is necessary to load the brake centrally. (Visual centering is sufficient.) If work is performed off-center, the guide pins could be damaged. The brake lift is provided by springs. If sticking occurs at the bottom of the stroke and the upper die does not return, usually a slight tap on the upper die is sufficient to free the guides.

DO NOT ATTEMPT TO FREE THE BRAKE BY HAND.

Sticking can be caused by lack of lubrication, complexity of the part being bent or bent guide pins. Keep the guides well lubricated and replace them if they are damaged.

It is common practice to have the bottom die opening 8 times the thickness of the material being bent. If the parts require a bend of less than 90 degrees, adjust the down stroke of the machine until the desired bend is obtained.

A great variety of standard brake dies can be used with this unit. These are available from Scotchman Industries or Brake Die suppliers. REMOVE THE TOOL WHEN IT IS NOT IN USE.

NOTE: If tool ever jams or gets stuck - REMOVE THE TOOL FROM THE MACHINE BEFORE ATTEMPTING TO FREE IT.

BRAKE TONNAGE CHART																							
PRESSURE IN TONS PER LINEAR FOOT REQUIRED TO MAKE 90 DEGREE AIR BEND IN MILD STEEL																							
THICKNESS OF METAL		WIDTH OF V-DIE OPENING																					
		1/4	5/16	3/8	1/2	5/8	3/4	7/8	1	1-1/8	1-1/4	1-1/2	2	2-1/2	3	3-1/2	4	5	6	7	8	10	12
GAUGE	INCHES	1/4	5/16	3/8	1/2	5/8	3/4	7/8	1	1-1/8	1-1/4	1-1/2	2	2-1/2	3	3-1/2	4	5	6	7	8	10	12
20	.036	2.9	2.2	1.7	1.2	1.0																	
18	.048		4.0	2.9	1.6	1.3																	
16	.060			5.6	3.6	2.7	2.2	1.7															
14	.075				6.0	4.5	3.4	3.0	2.5	2.1													
13	.090					6.8	5.4	4.3	3.7	3.3	2.9												
12	.105					10.1	7.4	6.3	5.4	4.4	4.0	3.2											
11	.120						10.5	8.8	7.2	6.2	5.4	4.3	3.2										
10	.135							11.3	9.6	8.4	5.6	4.1											
9	.150								13.1	11.9	9.0	6.7	5.2	3.5									
7	.188									16.4	14.0	11.2	7.6	5.8	4.5								
1/4	.250										28.8	22.0	15.3	11.5	9.1	7.5	6.2						
5/16	.313											38.0	26.0	19.2	16.0	12.5	10.6	7.6					
3/8	.375												41.0	29.9	24.0	19.4	16.0	12.3	9.3				
7/16	.438													45.2	35.0	28.0	24.0	17.0	14.6	11.1			
1/2	.500														47.9	39.0	33.1	24.0	19.0	15.6	12.7		
5/8	.625															69.5	58.0	42.2	32.4	26.0	23.0	16.5	
3/4	.750																92.0	69.0	52.2	42.2	36.0	27.0	21.0
7/8	.875																	104	80.0	63.0	52.5	39.4	31.2
1.0	1.00																		112	90.0	76.0	56.2	44.0

PRESSURES HIGHLIGHTED IN **BOLD** ARE FOR DIES WITH FEMALE DIE OPENINGS APPROX. 8 TIMES METAL THICKNESS, WITH RADIUS ON MALE DIE EQUAL TO METAL THICKNESS, AND ARE CONSIDERED IDEAL FOR RIGHT ANGLE BENDING.

BENDING PRESSURES REQUIRED FOR OTHER METALS AS COMPARED TO 65,000 P.S.I. TENSILE MILD STEEL ON CHART:

SOFT BRASS ----- 50% OF PRESSURE LISTED	SOFT ALUMINUM ----- 50% OF PRESSURE LISTED
ALUMINUM ALLOYS (HEAT TREATED) - SAME AS STEEL	STAINLESS STEEL ----- 50% MORE THAN STEEL
CHROME MOLYBDENUM ----- 100% MORE THAN STEEL	

FIGURE 19

7.6 ANGLE IRON BRAKE

This brake is designed to form box frames out of angle iron. It has a maximum capacity of 1/4" (6mm).

7.6A ANGLE IRON BRAKE INSTALLATION

SEE FIGURE 20 ON THE FOLLOWING PAGE.

This brake mounts in the punch station and the selector switch must be in the PUNCH position to operate this tool. The die holder, punch retaining nut and the stripper must be removed to install this tool. Mount the tool so that it lines up directly under the punch ram (A) and anchor it to the punch bed with the two M16 bolts used in the punch station and finger clamps (B) provided.

7.6B ANGLE IRON BRAKE OPERATION

The down stroke of the machine must be set, to prevent damage to the tool. Grease the brake guides every two hours of operation.

NOTE: If tool ever jams or gets stuck - REMOVE THE TOOL FROM THE MACHINE BEFORE ATTEMPTING TO FREE IT.

➡ **ALWAYS REMOVE THIS TOOL WHEN IT IS NOT IN USE.**

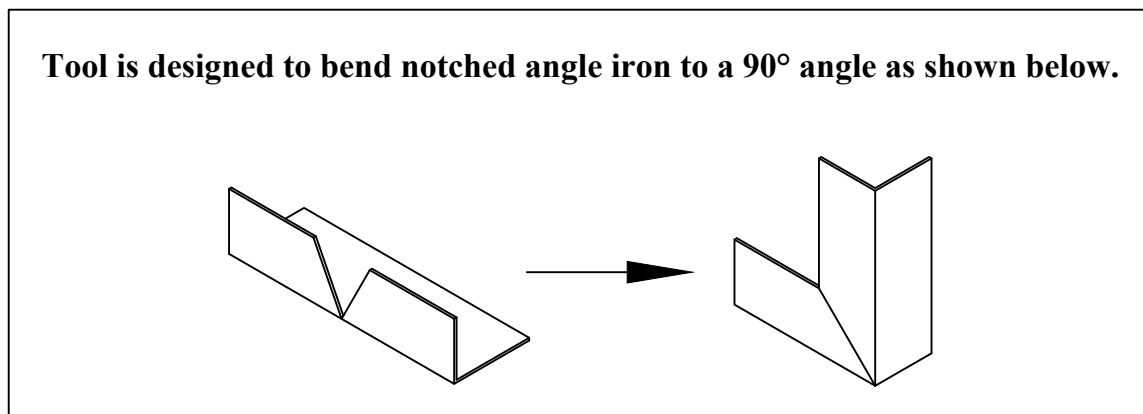

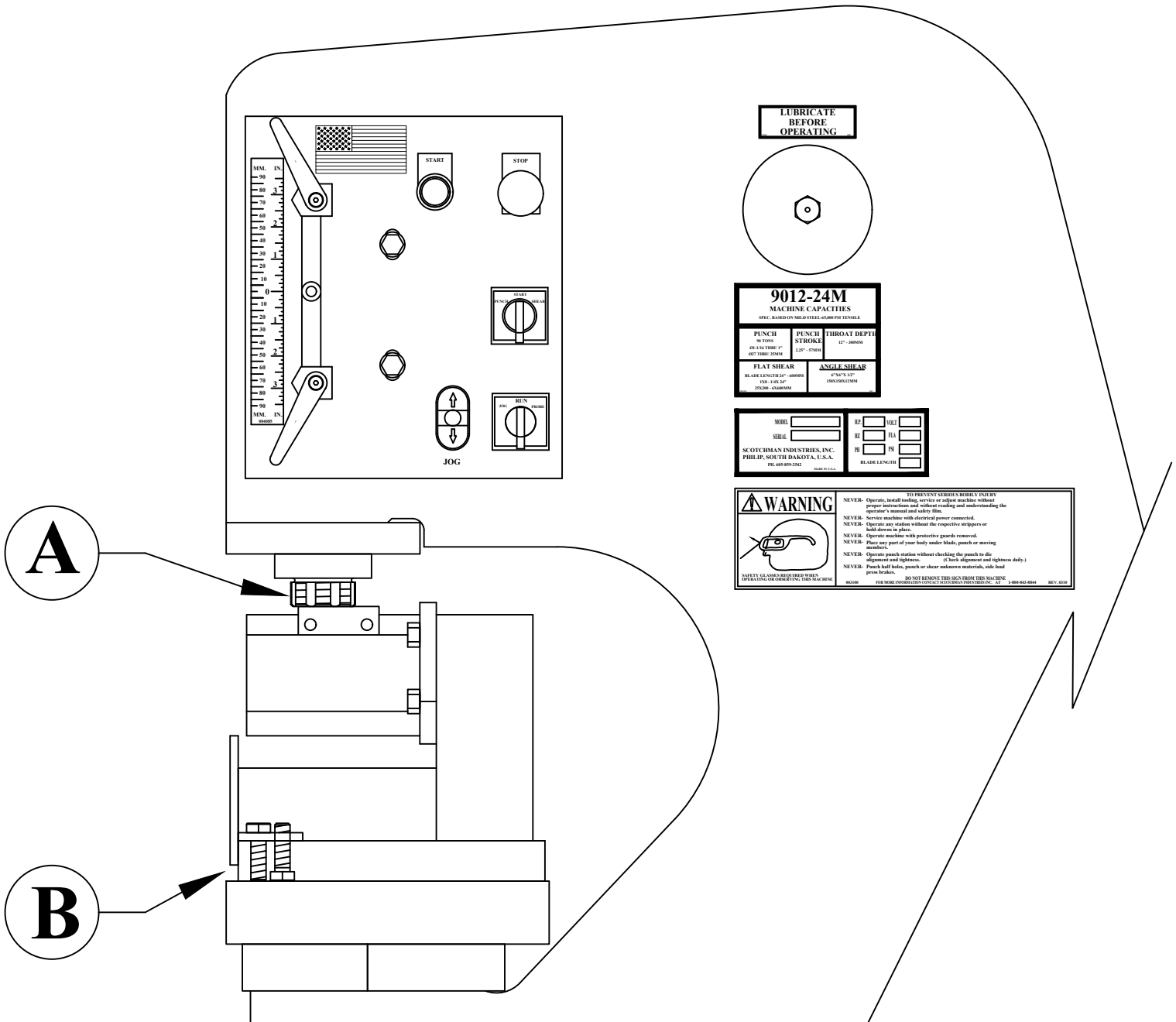

FIGURE 20

7.7 CHANNEL SHEAR

The Channel Shear is a component tool designed to shear 2 to 5 inch (51 to 127mm) standard channel on this model.

7.7A CHANNEL SHEAR INSTALLATION

SEE FIGURE 21 BELOW.

The Channel Shear installs under the upper arm in the tool station. The selector switch must be in the SHEAR position to operate this tool. Before installing the tool, remove the upper blade. Install the spring guide pins with the head of the pin down in the side plate of the shear. Slide the return springs over the guide pins, the short one first, followed by the long one.

REFER TO DRAWING ON THE RIGHT IN FIGURE 21 BELOW

Replace the top blade. Mount the shear as close to the frame as possible, with the locking handle to the cylinder end. Make sure that the slug slot in the tool aligns with the slug slot in the tool table. Anchor the tool with the finger clamps provided.

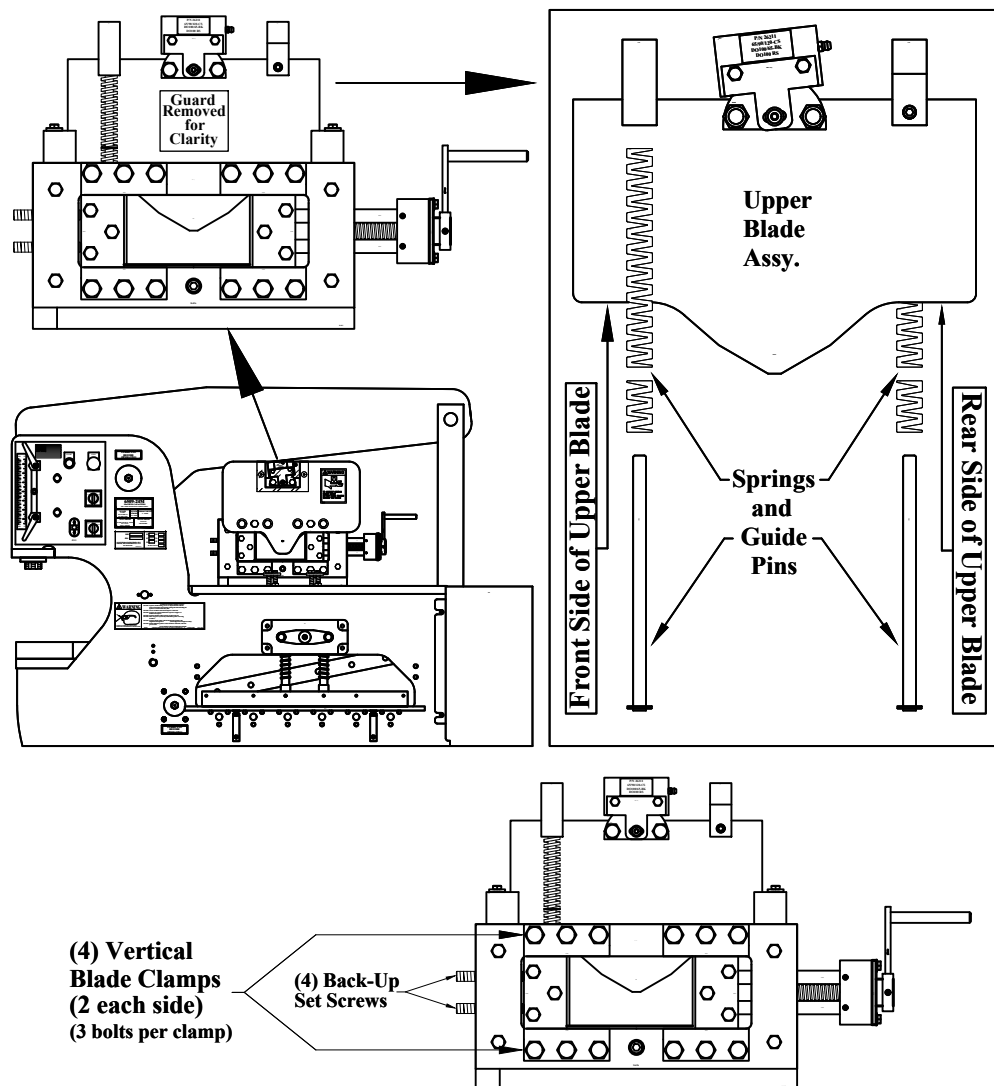

FIGURE 21

7.7B CHANNEL SHEAR OPERATION

The Channel Shear will shear from 2 to 5 inch (51 to 152mm) lightweight (5.4 lb/ft) channel with minimum distortion. Lubricate the blades before the first cut and every 10 to 15 cuts, thereafter. Grease the slider block between the upper arm and the tool every two hours of operation.

THE FOLLOWING ARE BASIC STEPS IN SHEARING WITH THE CHANNEL SHEAR.

- ADJUST BOTH MOVING AND STATIONARY SIDE BLADES TO THE SIZE OF CHANNEL BEING SHEARED.

Improper adjustment of the vertical blades will result in damage to the channel shear. To keep the channel centered in the unit, it is necessary to reset the stationary side blades for each size of channel.

ONE METHOD OF ACCOMPLISHING THIS ADJUSTMENT IS AS FOLLOWS:

Place a piece of channel, the size to be sheared, in the tool. Remove the lifting springs and lower the upper blade by hand until it contacts the channel iron. Locate the channel so that the upper blade contacts both legs, which will center it in the shear. Adjust the movable vertical blades up to the flange of the channel. Loosen the fixed vertical blade clamps (four places). Slide the fixed blades up to the channel flange. Tighten the blade clamps and adjust the back-up socket set screws up against the fixed vertical blades. Now, check to see that the blades have good alignment, front and back, and have maintained their perpendicularity to the lower blades.

- ▶ POSITION THE ADJUSTING HANDLE.

The adjusting handle can be relocated to permit easy opening and closing of the movable vertical blades. (Approximately 1/2 turn will lock and unlock the workpiece.)

- ▶ SET THE BOTTOM OF THE STROKE AS LOW AS POSSIBLE.

The bottom of the stroke should be set as low as possible, without bottoming any part of the upper blade, blade holder or pressure block. The upper stroke should be set to allow the workpiece to feed through the shear freely.

- ▶ PROCEDURE FOR SHEARING:

Lubricate the blades with oil before making the first cut and every 10 to 15 cuts, thereafter. This lubrication is critical on the channel shear.

Position the workpiece. Snug the movable blades up to the channel's flange. Depress the foot switch and shear the workpiece. Before releasing the foot switch, back the movable blades off by 1/2 turn of the locking handle. Make sure that the slug drops from the chute after each stroke.

All of the bottom and vertical blades are symmetrical and can be turned to present four (4) cutting edges. Clearance between the upper and lower blades is changed by the addition or removal of shims. A clearance of twenty thousandths of an inch (.5mm) is recommended. For efficient shearing, blades must be kept sharp.

NOTE: If tool ever jams or gets stuck - REMOVE THE TOOL FROM THE MACHINE BEFORE ATTEMPTING TO FREE IT.

- ⊠ CAUTION: ALWAYS REMOVE THIS TOOL WHEN IT IS NOT IN USE.

7.8 PIPE NOTCHER

The Pipe Notcher is a component tool designed to saddle cut pipe or tubing for applications such as railings. There are notchers available to notch angles in pipe and tubing, also. For prices and availability, contact your local dealer or the factory.

7.8A PIPE NOTCHER INSTALLATION

SEE FIGURE 22 ON THE FOLLOWING PAGE.

The pipe notcher can be installed in either the punch station or under the upper arm.

When installed on the tool table, the selector switch must be in the SHEAR position.

When installed in the punch station, the selector switch must be in the PUNCH position.

WHEN INSTALLING THE NOTCHER IN THE PUNCH STATION:

1. Remove the die holder and the stripper.
 2. Install the pusher (F) on the punch ram, using the #45 punch retaining nut (C).
- **NOTE:** The upper and lower dies have an alignment pin and groove in them to prevent mismatching sizes. Make sure that the dies you have selected are a matched set, before installing them.
3. Set the notcher (A) on the bolster and align the slug hole in the notcher with the hole in the bolster.
 4. Anchor the tool with the M16 bolt (D) provided.

TO MOUNT THE NOTCHER ON THE TOOL TABLE:

1. Attach the riser (B), Spacer (B1) and the pusher (E) to the tool using the two M10 x 70 bolts and lock washers. See "Tool Table Configuration" on the middle-right in FIGURE 22 on the next page.
2. Align the tool over the "D" shaped slug hole in the tool table (as shown) and bolt it down to the tool table with the M12 bolt (G) provided.
3. Both the 6 x 6 Angle Shear and Pipe Notcher can be used on the tool table at the same time.

⊠ **CAUTION:** WITH THE TOOL MOUNTED IN EITHER STATION, IT IS NECESSARY TO SET THE DOWNSTROKE OF THE MACHINE TO PREVENT DAMAGE TO THE TOOL. THE UPPER DIE SHOULD NOT PASS THE LOWER DIE BY MORE THAN 1/32 OF AN INCH (.7MM).

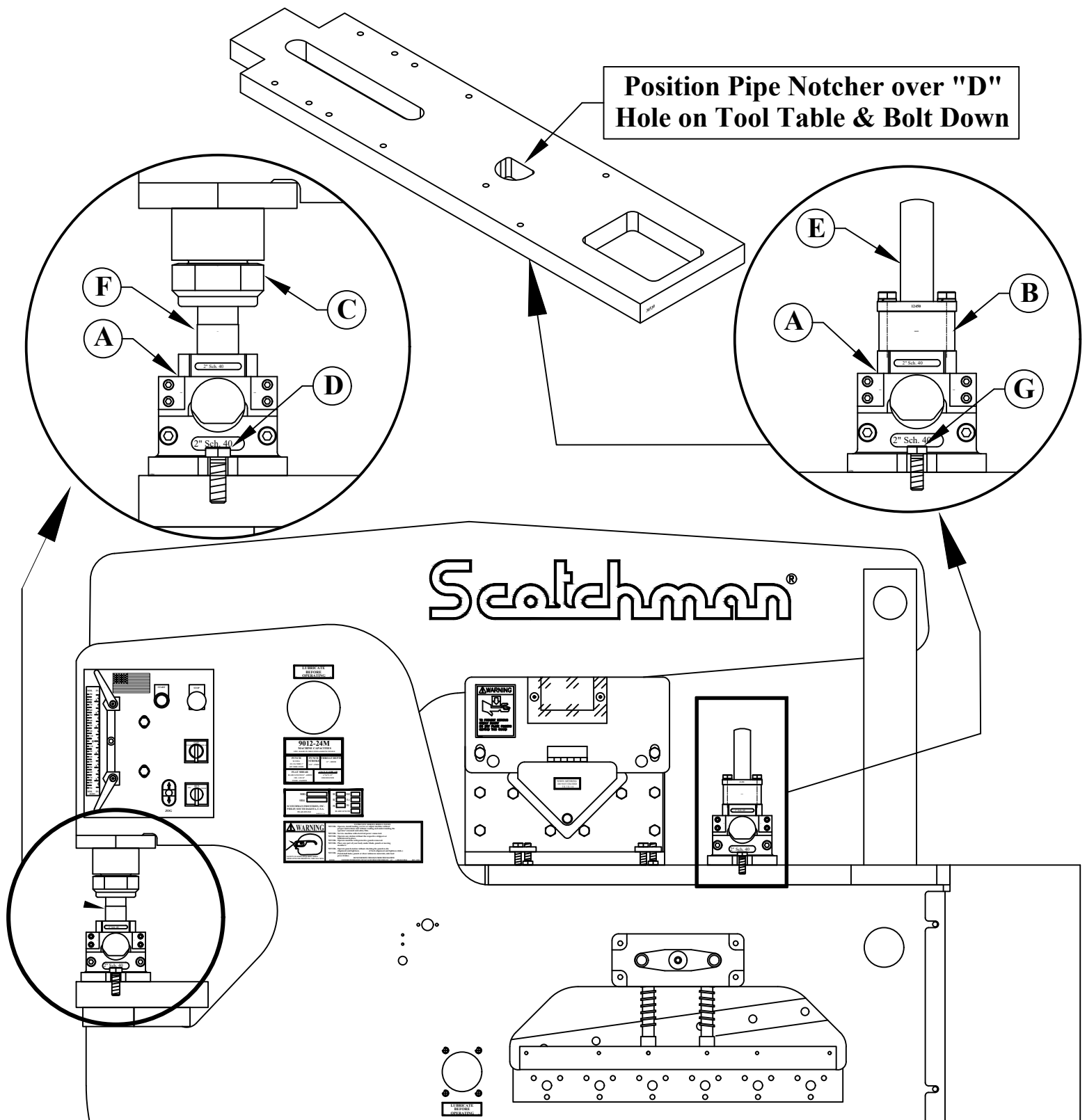

FIGURE 22

7.8B PIPE NOTCHER OPERATION

To achieve the best results from your unit, PLEASE OBSERVE THESE SIMPLE RULES:

1. Keep the unit clean. Whenever dirt or metal chips accumulate, remove the 8mm limit screw located in the center at the rear of the punch. Lift out the punch-holder and the two springs (1/2 x 3"). Clean the unit with solvent.

⊗ CAUTION: DO NOT DISASSEMBLE THE UPPER PUNCH.

2. Check the alignment of the unit. After cleaning the unit, always check the alignment of the punch and die section. To check the alignment, insert the punch and holder, without the springs, into the housing and check the gap. SEE FIGURE 23 BELOW.
3. If proven correct, tighten the two M10 socket head screws holding the die section in place.
4. Apply some high pressure lube all around the inside of the housing, then re-assemble the unit, reversing the above procedures.

⊗ CAUTION: WHEN USING THIS TOOL, ALWAYS WEAR SAFETY GLASSES.

7.8C PIPE NOTCHER CAPACITIES

Two inch (2") Schedule 80 is the maximum thickness that can be cut. Lighter weight tubing may be cut, but will probably require different dies for best cutting results. Separate dies are required for each size pipe or tubing being notched.

NOTE: If tool ever jams or gets stuck - REMOVE THE TOOL FROM THE MACHINE BEFORE ATTEMPTING TO FREE IT.

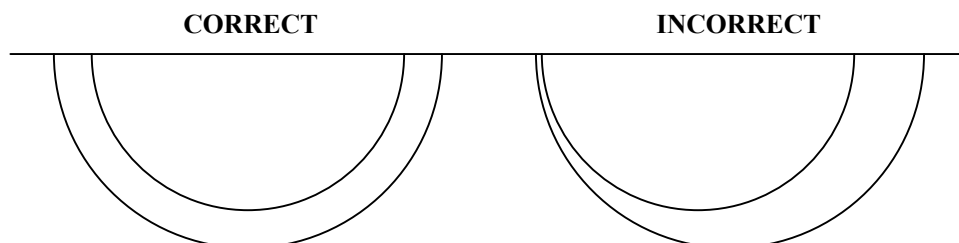

FIGURE 23

7.9 PICKET TOOL INSTALLATION & OPERATION

The picket fence tool is designed to make picket points on square tubing for ornamental and security fence applications. The tool has a maximum of 1 inch (25mm) 16 gauge square tubing.

This tool mounts in the punch station only. REFER TO THE DRAWING BELOW. The machine must be in the PUNCH position to operate this tool. Remove the die holder, stripper and the punch retaining nut. Install the tool so that the punch ram aligns with the ram on the picket tool and, with the finger clamps (C) provided, anchor it to the punch bolster.

⊗ **CAUTION:** THE DOWNSTROKE OF THE MACHINE MUST BE SET BEFORE OPERATION OF THE TOOL. FAILURE TO SET THE DOWNSTROKE OF THE MACHINE WILL RESULT IN DAMAGE TO THE TOOL.

1. Set the down stroke of the machine so that the upper die clears the lower die by twice the wall thickness of the tube, plus 1/32 of an inch (.8mm).
2. Adjust the tube stop (A) just low enough to contact the upper edge of the tube.
3. Adjust the rest stop (B) so that it is approximately half of the tube size below the lower die.
4. Feed the tube into the tool until it contacts the stop (A). Depress the foot pedal.
5. Make sure that the slugs eject from the tool as the next piece is fed into the tool.
6. Lubricate the dies every 10 to 15 cuts and grease the ram daily.

NOTE: If tool ever jams or gets stuck - REMOVE THE TOOL FROM THE MACHINE BEFORE ATTEMPTING TO FREE IT.

⊗ **CAUTION:** ALWAYS REMOVE THIS TOOL WHEN IT IS NOT IN USE.

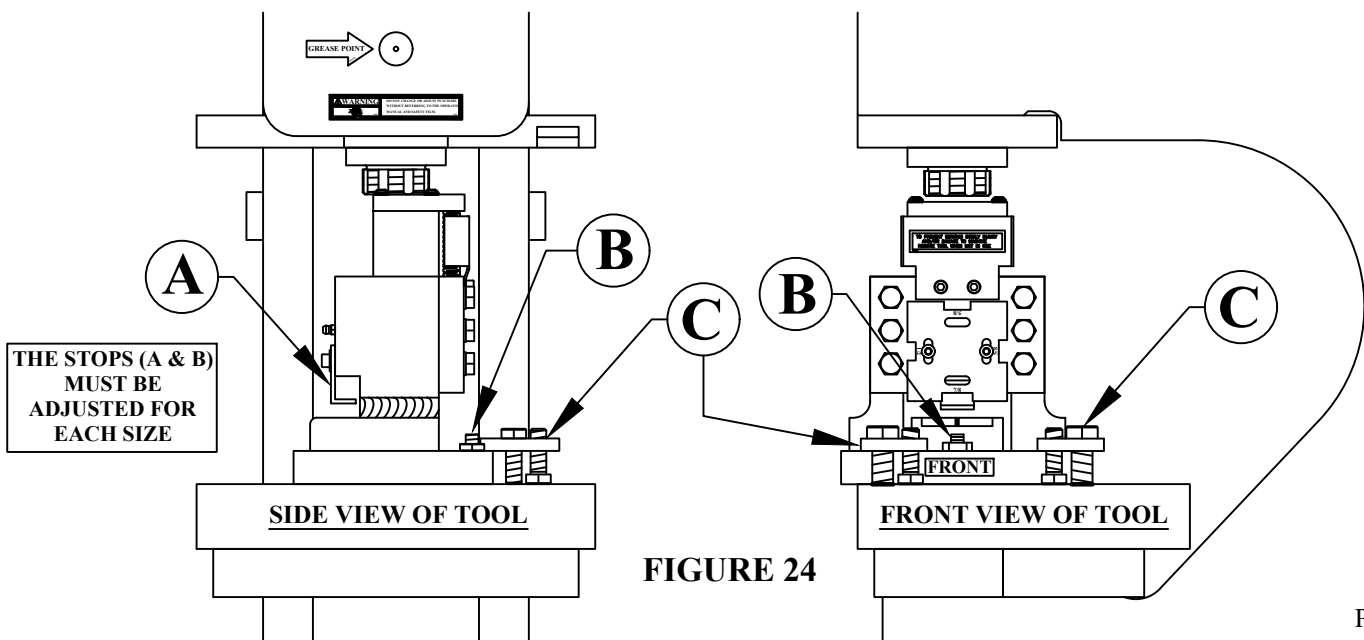

7.10 SQUARE TUBE SHEAR

SEE FIGURE 25 ON THE FOLLOWING PAGE.

The square tube shear is designed to shear square tubing from 1/4" to 2" (6mm to 51mm).

16 gauge (.060 or 1.5mm) is the maximum material thickness.

7.10A SQUARE TUBE SHEAR INSTALLATION

This tool mounts on the tool table. The machine must be in the SHEAR position to operate this tool.

1. Mount the tool over the slug release slot in the table and squarely under the upper arm.
2. Grease the pressure cap (A) before using and every two hours, thereafter.
3. Anchor the tool with the finger clamps (C) provided.
4. Set the upstroke of the machine so that the size of tube you want to shear will feed through the tool.

Make sure that the upstroke is set so that there is spring tension on the pressure block at all times.

5. Set the down stroke so that the upper blade passes the lower blade by approximately 1/8" (3mm).

7.10B SQUARE TUBE SHEAR OPERATION

1. The selector switch must be in the SHEAR position to operate this tool.
2. Set the down stroke of the machine so that the upper blade passes the lower blade by approximately 1/8 of an inch (3mm).
3. Feed the tubing through the shear to the desired length and depress the foot pedal.
4. Lubricate the blades every ten to fifteen cuts.

NOTE: If tool ever jams or gets stuck - REMOVE THE TOOL FROM THE MACHINE BEFORE ATTEMPTING TO FREE IT.

⊗ **CAUTION: ALWAYS REMOVE THIS TOOL WHEN IT IS NOT IN USE.**

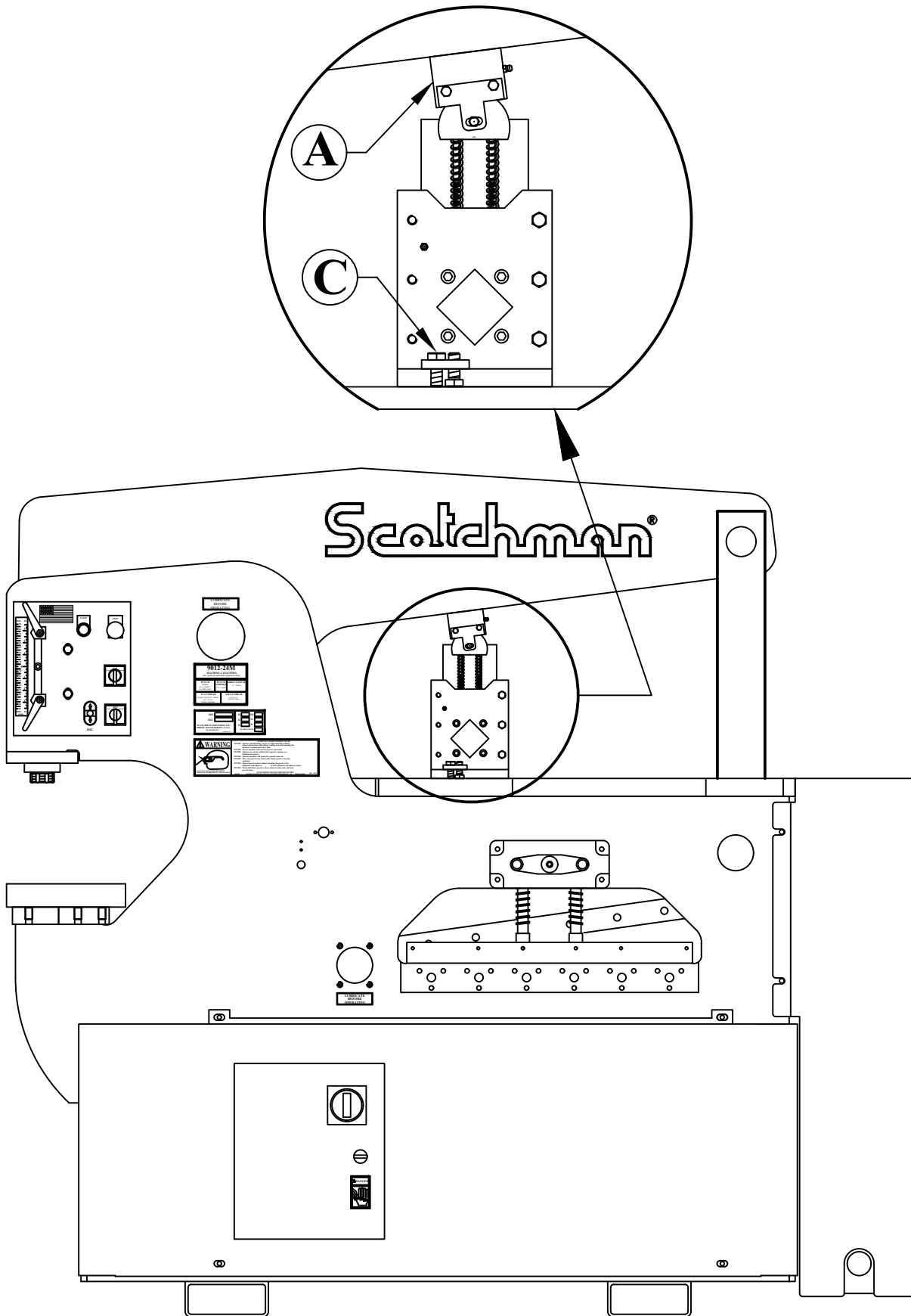

FIGURE 25

7.11 OPTIONAL PUNCH AND DIE HOLDERS

7.11A 2-1/2" AND 3" DIE INSERTS

The 2-1/2 and 3 inch (63 and 76mm) die inserts are designed to fit in the standard die holder in place of the 2 inch (51mm) insert. They are used in oversize punching applications. For applications, **REFER TO THE PUNCH AND DIE SECTION OF THE TOOLING PARTS MANUAL.**

7.11B OFFSET DIE HOLDER FOR FLANGE PUNCHING

The offset die holder is used for punching holes in the flange of structural shapes such as channel, I-beam and H-beam. The offset die holder is installed in place of the standard die holder. The offset die holder requires four bolts to anchor it to the bolster. Use the two bolts provided with the die holder. Use the same method of installing and aligning punches and dies as outlined in SECTION 6.1, with a few exceptions. The die holder must be removed to install a new punch and die. The down stroke of the machine must be set. Use the instruction sheet that came with the die holder.

CAUTION: FAILURE TO SET THE STROKE WILL ALLOW THE PUNCH RETAINING NUT TO STRIKE THE DIE HOLDER, CAUSING DAMAGE TO THE MACHINE AND POSSIBLE INJURY TO THE OPERATOR. BECAUSE OF ITS DESIGN, THE OFFSET DIE HOLDER HAS A MAXIMUM CAPACITY OF 40 TONS. EXCEEDING 40 TONS WILL DAMAGE THE TOOL AND MAY CAUSE INJURY TO THE OPERATOR. FOR PUNCH TONNAGE REQUIREMENTS, REFER TO FIGURE 9 ON PAGE 28.

The offset die holder is designed to be used in conjunction with an offset stripper. The standard stripper will not work with the offset die holder.

7.11C 6 X 6 DIE HOLDER

Always follow the preferred method of aligning punches and dies. SEE SECTION 6.1. The 6 x 6 die holder is installed in place of the standard die holder. The 6 x 6 die holder requires four mounting bolts that are shipped with the tool. Capacities for oversize punching with this tool go up to 4 inch (102mm) diameter rounds. For sizes and applications, **REFER TO THE PUNCH AND DIE SECTION OF THE TOOLING PARTS MANUAL.**

7.11D # 45 PUNCH RETAINING NUT

The #45 punch retaining nut is of the same design as the #40 and is used in oversize punching applications. For applications, refer to the **PUNCH AND DIE SECTION OF THE TOOLING PARTS MANUAL.**

7.11E HEAVY DUTY SPLIT RING RETAINING NUT

SEE FIGURE 26 BELOW.

The heavy duty split-ring retaining nut is used in oversize punching applications that require a punch with a 2 inch (51mm) shank diameter (E). This retaining nut requires a pin wrench (F), which should be ordered when ordering the nut. Follow the instructions in SECTION 6.1 for proper punch and die alignment. To use the heavy duty split-ring retaining nut, remove the six socket head cap screws (D). Slide the retaining ring (C) over the punch shank. Place the split-ring (B) into the groove on the punch. Place the ring nut (A) on the punch and replace the six socket head cap screws (D). Remove the bottom of the standard stripper when using this punch.

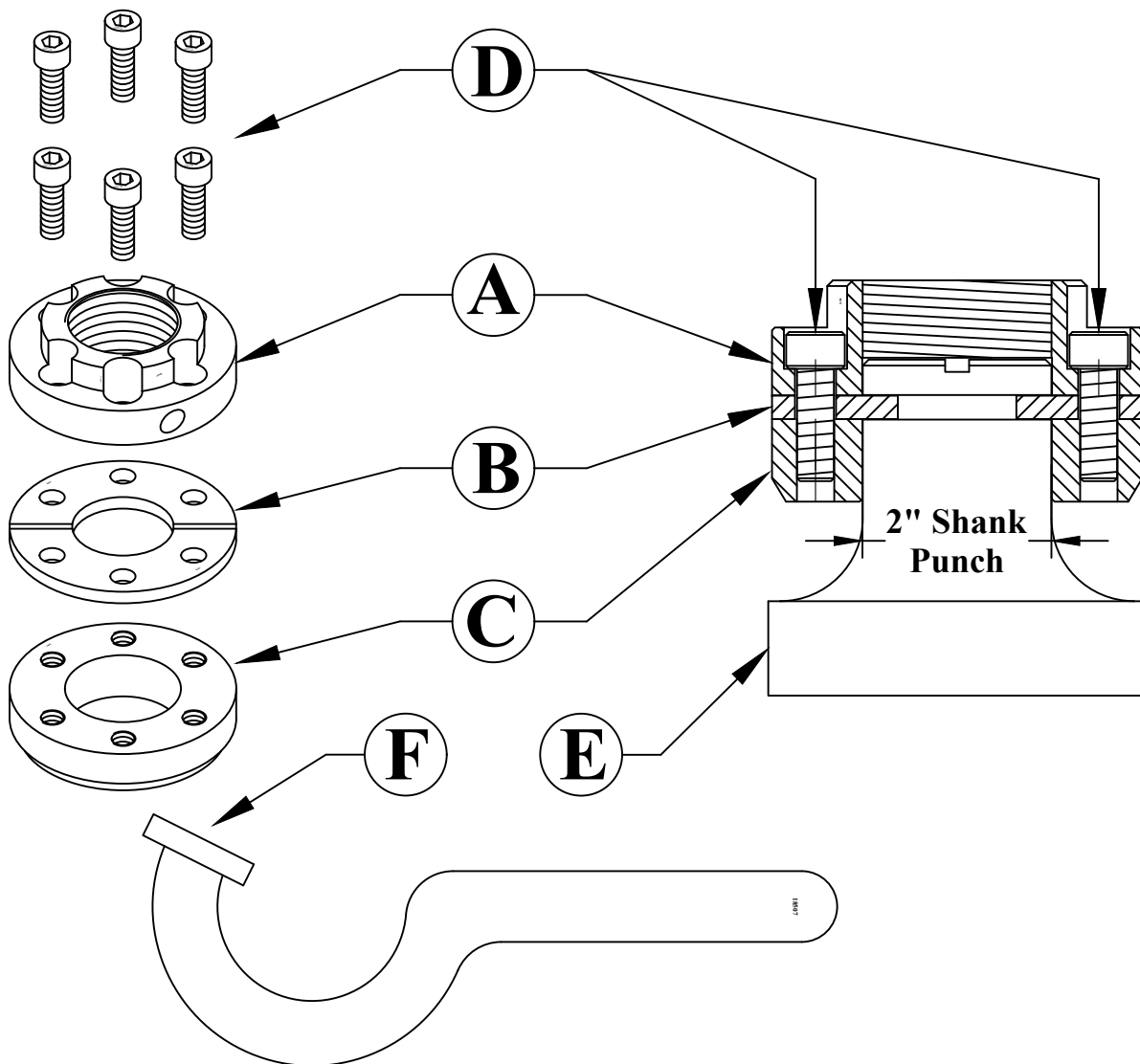

FIGURE 26

7.12 OPTIONAL GAUGING EQUIPMENT

7.12A 48 INCH (122 CM) DELUXE BACK GAUGE

The 48 inch (122cm) back gauge mounts on the drop-off side of the machine and will reach all three stations from one point. It is designed to be used as a length stop in the shear, punch and tooling stations.

7.13 URETHANE STRIPPER

Scotchman does not recommend this unit for all general punching applications. However, using this specially designed "Non Deform" stripper unit does offer a significant advantage over a standard stripper arrangement in reducing distortion when punching a confined pattern or series of holes in flat bar or plate.

- **NOTE: THIS STRIPPER ONLY WORKS WITH #40 TOOLING. THE MAXIMUM HOLE SIZES THAT CAN BE PUNCHED ARE 1-1/4 (32mm) ROUND AND OVAL AND 3/4 (19mm) SQUARE. THE MAXIMUM MATERIAL THICKNESS FOR THIS STRIPPER IS 3/4" (19mm).**

The action of this unit will minimize distortion in the work piece and in many cases eliminate costly correction and straightening processes. Of course, there is a limit how much material can be removed in a confined area without causing some deformation. Contact your dealer or Scotchman for advice. Combining this unit with a linear feed repetitive stop system for punching a series of holes in flat bar will significantly increase productivity.

Because of the action of this type of unit, particular attention must be paid when setting the stroke length. The stripper unit moves in conjunction with the punch and extra care must be taken by the operator. (Refer to the setting and operating instructions in this section.)

The maximum thickness which can be punched using this unit is 3/4" (19mm) in steel with a rated tensile strength of 65,000 lbs. psi.

7.13A CHANGING THE URETHANE SPRINGS

If the unit is constantly over stroked or over a period of time, it may be necessary to renew the urethane springs. REFER TO FIGURE 27 ON PAGE 61. The springs should be checked periodically. (A sure sign of over stroking is cracking or splitting of the springs.)

1. Secure the unit in a vise by clamping the bottom plate (item11).
2. Loosen and remove both nyloc nuts (6). When loosening the nyloc nuts, if one or both tie rods (4) become loose, remove the loose tie rod(s) from the base plate and remove the nut(s) from the tie rod(s). Re-tighten the tie rod(s) into the base plate and lock in place, using a thread locking solution such as Nutloc.
3. Remove the top plate (7) and spring spacers (1).
4. Remove the urethane springs (3).
5. Re-assemble the unit with new urethane springs and finger tighten both nyloc nuts.
6. Tighten both retaining nuts to achieve the correct setting distance.

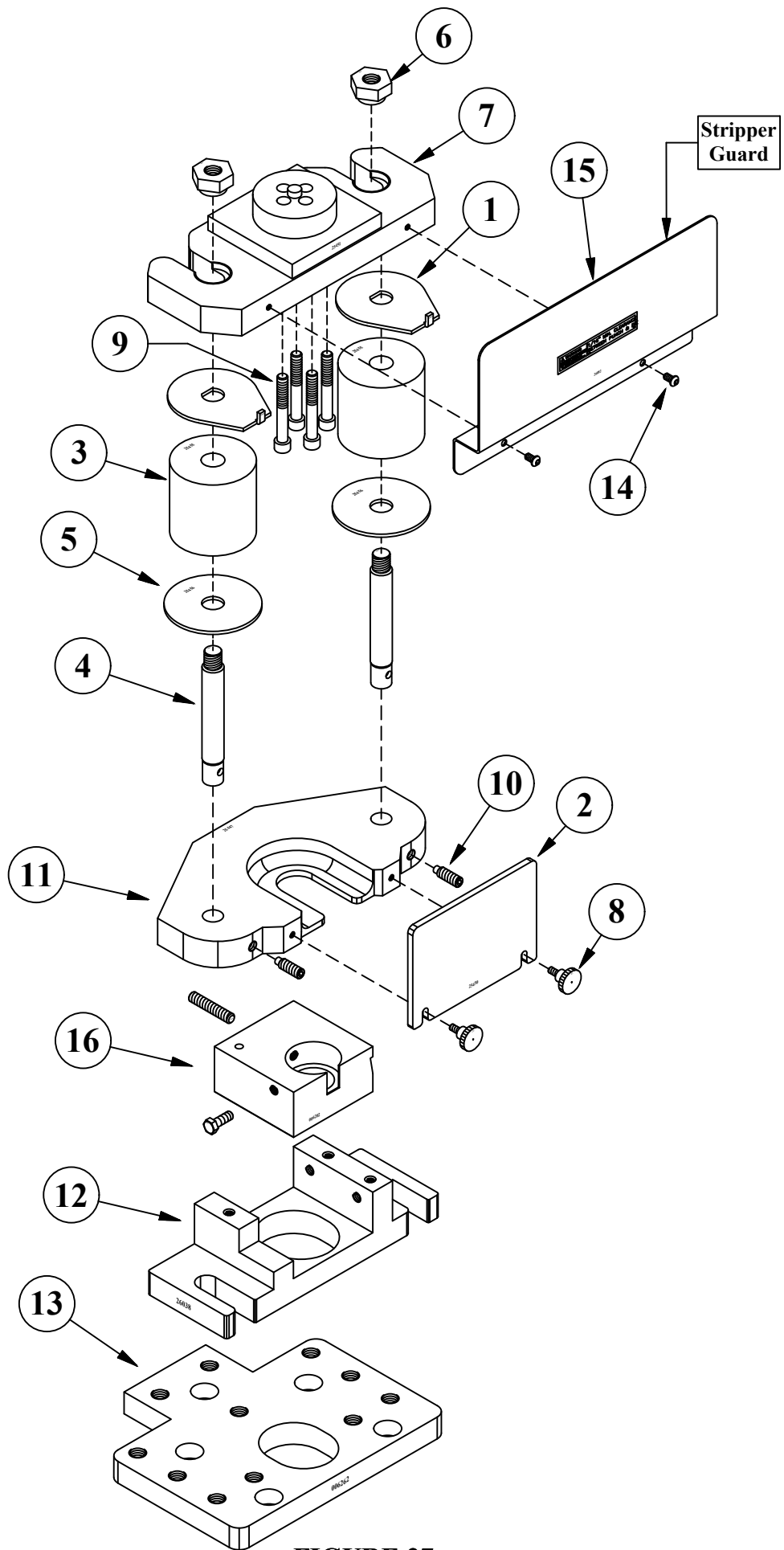

FIGURE 27

7.13B INSTALLING THE URETHANE STRIPPER & PUNCH & DIE

REFER TO FIGURE 28.

- 1. Raise the top limit switch to its highest position. Power the machine and let the punch ram retract to its full UP position.**
- 2. Open the standard stripper and remove it from the machine by removing the left hand mounting bolt.**
- 3. If there is a punch and die installed in the machine, remove them.**
- 4. Remove the two bolts holding the die holder and remove the die holder.**
- 5. Remove the punch bolster and replace it with the bolster provided. Replace the die holder with the With the die holder provided with the urethane stripper. Do not tighten the bolts yet.**
- 6. Remove the punch holder (B) from the end of the ram.**
- 7. Disassemble the urethane stripper by removing the two retaining nuts (I).**
- 8. Install the stripper mounting plate (A) and the punch holder (B) to the ram, with the bolts provided.**
- 9. Select the proper punch and die. Make sure there is proper clearance between the punch and die.**
- 10. Clean both the punch and die of any foreign material.**
- 11. Insert the proper die in the die insert. (If the die has a flat spot in it, align this with the bolt in the die insert.) Tighten the bolt firmly with a wrench.**
- 12. Insert the punch into the punch retaining nut. Make sure that it seats properly. Place the punch retaining nut assembly on the die insert, with the punch inserted in the die.**
NOTE: IF YOU ARE USING PUNCHES THAT REQUIRE A KEY, INSERT THE KEY IN THE PUNCH AT THIS POINT.
- 13. Place the disconnect switch in the ON position and the selector switch in the START position. Power the machine by pressing the green START button.**
- 14. Check to make sure that there are no objects (such as tools) under or on any of the moving parts.**
- 15. Place the selector switch in the JOG position and carefully inch the cylinder ram to its set DOWN position.**
- 16. Turn the machine's power OFF.**
- 17. Lift the punch retaining nut and turn it on to the punch ram. (The die holder may have to be moved slightly to align the punch retaining nut to the punch ram.) When using keyed punches, after you start the nut on the ram, raise the punch and rotate it until the key seats in the punch ram.**
- 18. Use a wrench to tighten the punch retaining nut. Make sure that there is equal clearance on all sides of the punch in the die.**
- 19. Re-tighten the bolts in the die holder.**
- 20. Check to be sure of proper alignment. Realign, if necessary.**
- 21. Power the machine and raise the ram to the top of its stroke and turn the machine OFF.**

21. Slide the bottom half of the urethane stripper onto the stripper mounting plate (A) from the inside of the machine.
22. Make sure that the spring retainers (G) are positioned so that the lip on the retainer fits against the machined area on the front of the mounting plate (A). Finger tighten the retaining nuts (I).
23. Power the machine and jog the ram down until the urethane stripper contacts the top of the die holder. Continue to jog the ram down, compressing the urethane springs until the retaining nuts (I) can be tightened down to the shoulder on the stud.
24. Install the stripper guard (H) on the front of the stripper.

⊠ **CAUTION: REMEMBER THAT THE MAXIMUM CAPACITY OF THIS STRIPPER IS 1 INCH MATERIAL. ALSO, REMEMBER THAT THE STRIPPER MOVES WITH THE PUNCH.**

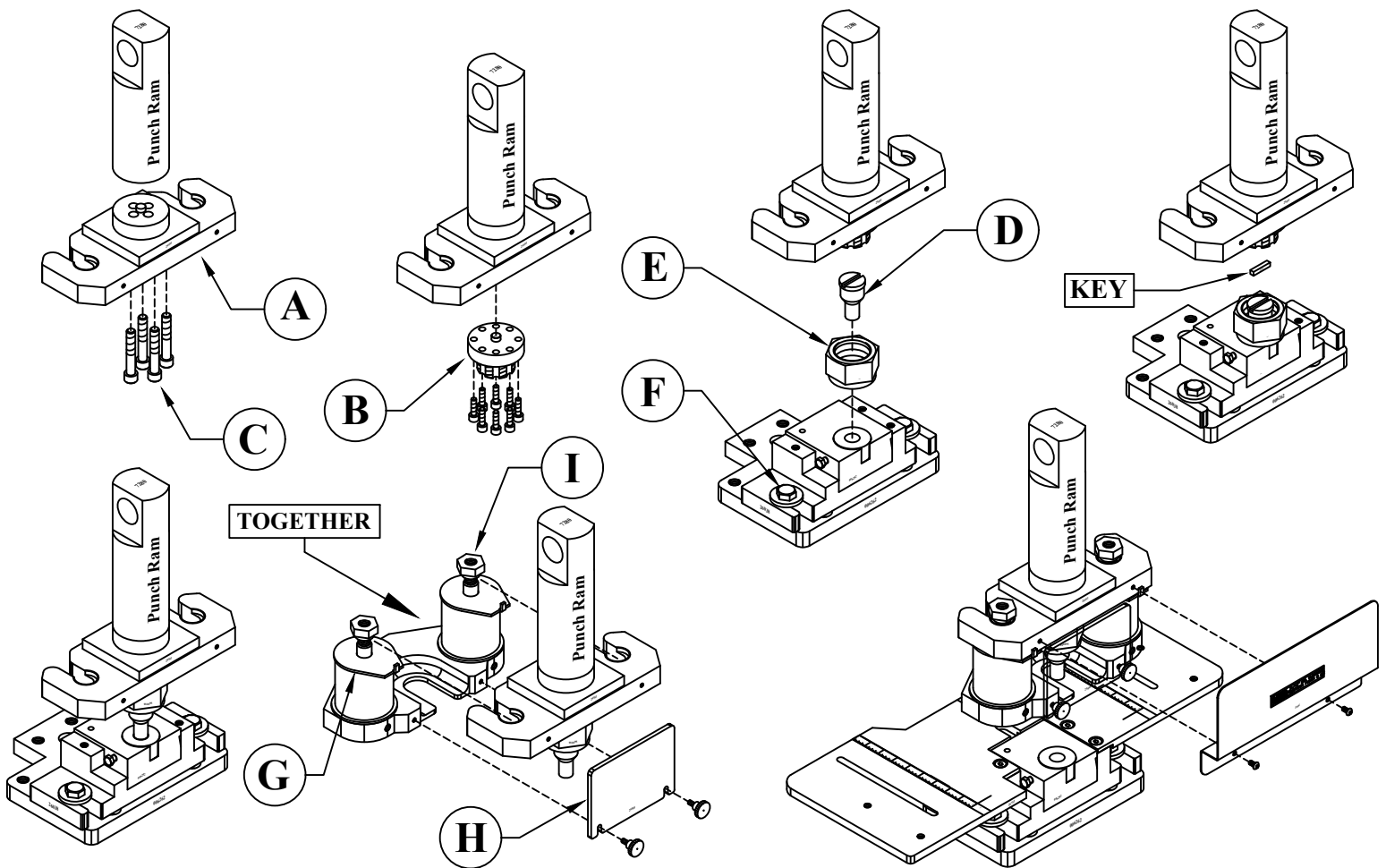

FIGURE 28

7.14 WELD COUPON BENDER TOOL

The Weld Coupon Bender Tool is designed to bend welded test coupons into "U" and "V" shapes for the purpose of testing soundness and ductility of welds. The maximum size of a test clip is 7" long x 2" wide x 3/8" (178 x 51 x 10mm) thick. Rollers are 4" apart (102mm).

7.14A WELD COUPON BENDER TOOL INSTALLATION

SEE FIGURE 29 ON THE FOLLOWING PAGE.

1. The Weld Coupon Bender Tool mounts on the tool table under the upper arm and is held in place with two finger clamps (A). Use the 3rd set of holes from the left (punch end) on the tool table and mount it as shown in the drawing.
- **NOTE: THE DOWN STROKE MUST BE SET PROPERLY WITH THIS TOOL.**
2. Make sure that the rocker cap (B) is squarely under the arm and that the stationary back of the coupon bender is clear of the moving arm of the ironworker.
 3. On the left side of the tool, under the roller, there are two lines machined in the tools back support. The upper line is for when the "V" die is used and the lower line is for when the "U" die is used. Stroke is to be set by aligning the bottom of the ram with the appropriate line machined in the back support. Please see the drawing under "Setting the Stroke".

7.14B WELD COUPON BENDER TOOL OPERATION

1. Grease the rocker cap (B) between the upper arm and the tool and again after every two hours of use. Grease the ram, using the two grease zerks on the side.
2. Lightly grease the rollers, using the two grease zerks on the front of the weld tester. Make sure that the rollers still turn easily; too much grease can cause the tool to not work properly.
3. Lightly lubricate the underside of the die and the outside of the two rollers with a spray lube such as WD-40 and again, every 10-15 bends, thereafter.
4. Insert the weld test coupon by sliding it on to the rollers. Using the back of the weld tester, square up the test piece and then, move it forward enough to center it under the die. Make sure that the weld test coupon is square and centered under the die.
5. Make sure that the down stroke of the tool is set so that the bottom of the ram - NOT the die - is aligned with the correct scribe line.
6. After bending the weld test coupon, let the tool return to the resting position. Remove the test coupon and inspect the weld. The tool can be seen in use at www.scotchman.com.

NOTE: If tool ever jams or gets stuck - REMOVE THE TOOL FROM THE MACHINE BEFORE ATTEMPTING TO FREE IT.

⊗ **CAUTION: ALWAYS REMOVE THIS TOOL WHEN IT IS NOT IN USE.**

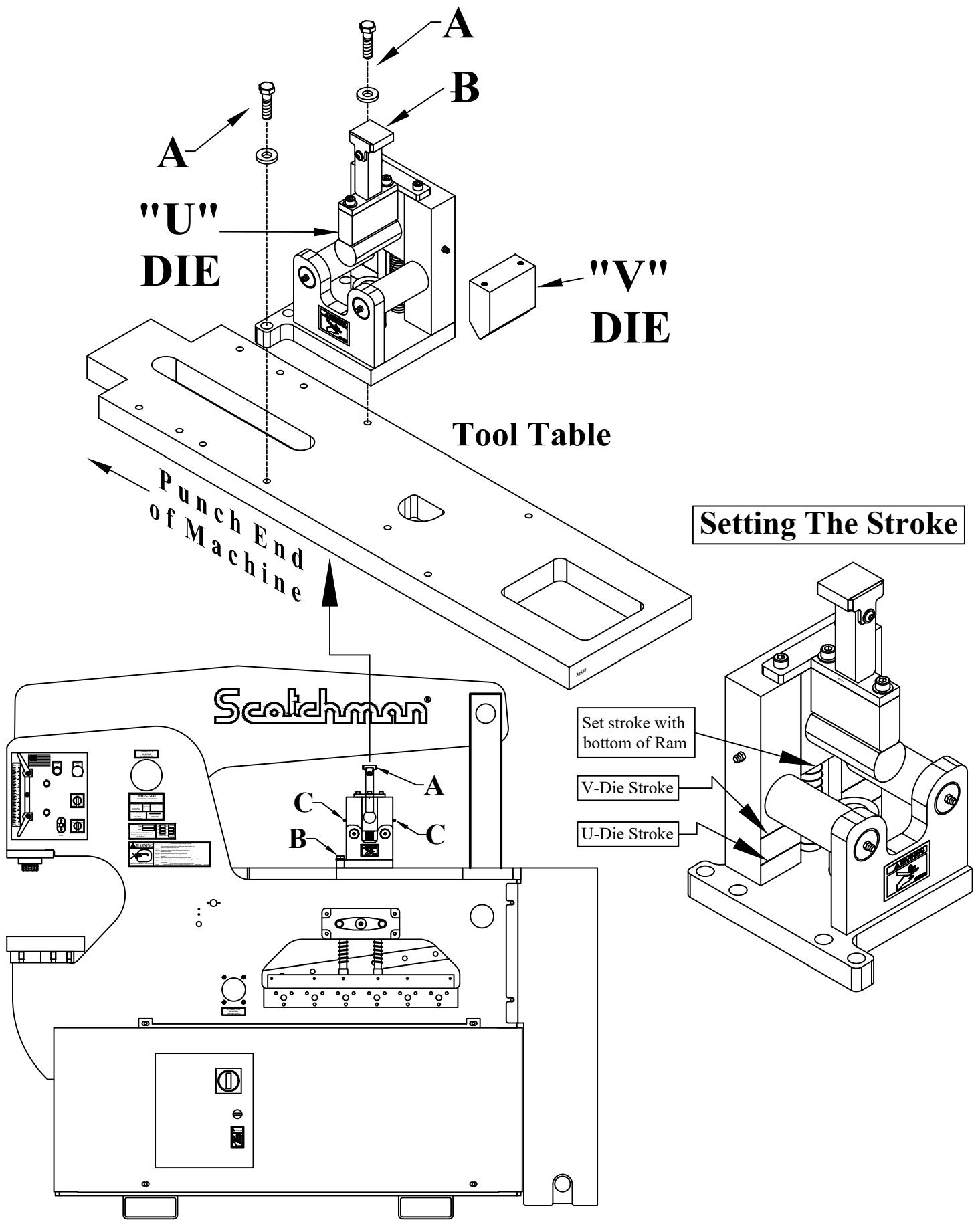

FIGURE 29

7.15 MULTI-SHEAR TOOL

The Multi-Shear tool is designed to shear standard Unistrut profiles, as well as many other specialty profiles.

7.15A MULTI-SHEAR TOOL INSTALLATION

SEE FIGURE 30 ON THE FOLLOWING PAGE.

If the punch and die are mounted on the machine, REMOVE THEM.

1. Turn the machine on and put it in the SHEAR position. Run the punch beam above the tool table up to its highest setting.
2. Place the tool on the tool table under the punch beam, keeping it towards the punch end of the tool table.
3. Use two finger clamps (B) and loosely mount the tool, using the 1st and fourth set of holes from the left on the tool table, using one "front" hole and one "rear" hole, as shown.
DO NOT place the Multi-Shear tool any further towards the rear of the machine, due to possible "bottoming out".
4. Make sure the tool is located under the beam correctly by aligning the pressure cap (A) under the beam. Once the tool is squarely under the beam, tighten the finger clamps (B) to hold the tool in place.
5. Set the upstroke of the machine so that the size of material that you want to shear will feed through the tool.
6. Make sure that the upstroke is set so that there is spring tension on the pressure block at all times.
7. Set the down stroke of the machine so that the moving blade travels only far enough to shear the material and no further.

7.15B MULTI-SHEAR TOOL OPERATION

1. The selector switch must be in the SHEAR position to operate this tool.
2. Set the down stroke of the machine so that the moving blade travels only far enough to shear the material and no further. "Bottoming out" this tool may ruin it!!
3. Feed the material through the shear to the desired length and depress the foot pedal. The Material Length Stop (C) simply screws into the back of the tool and is easily adjusted.
4. The pressure cap (A) has a grease zerck and the tool has two (2) grease zercks; one on each side. Grease before using and every two hours thereafter.
5. Lubricate the blades every ten to fifteen cuts.

NOTE: If tool ever jams or gets stuck - REMOVE THE TOOL FROM THE MACHINE BEFORE ATTEMPTING TO FREE IT.

⊗ **CAUTION: ALWAYS REMOVE THIS TOOL WHEN IT IS NOT IN USE.**

NOTE: See-Thru Guard is for Clarity

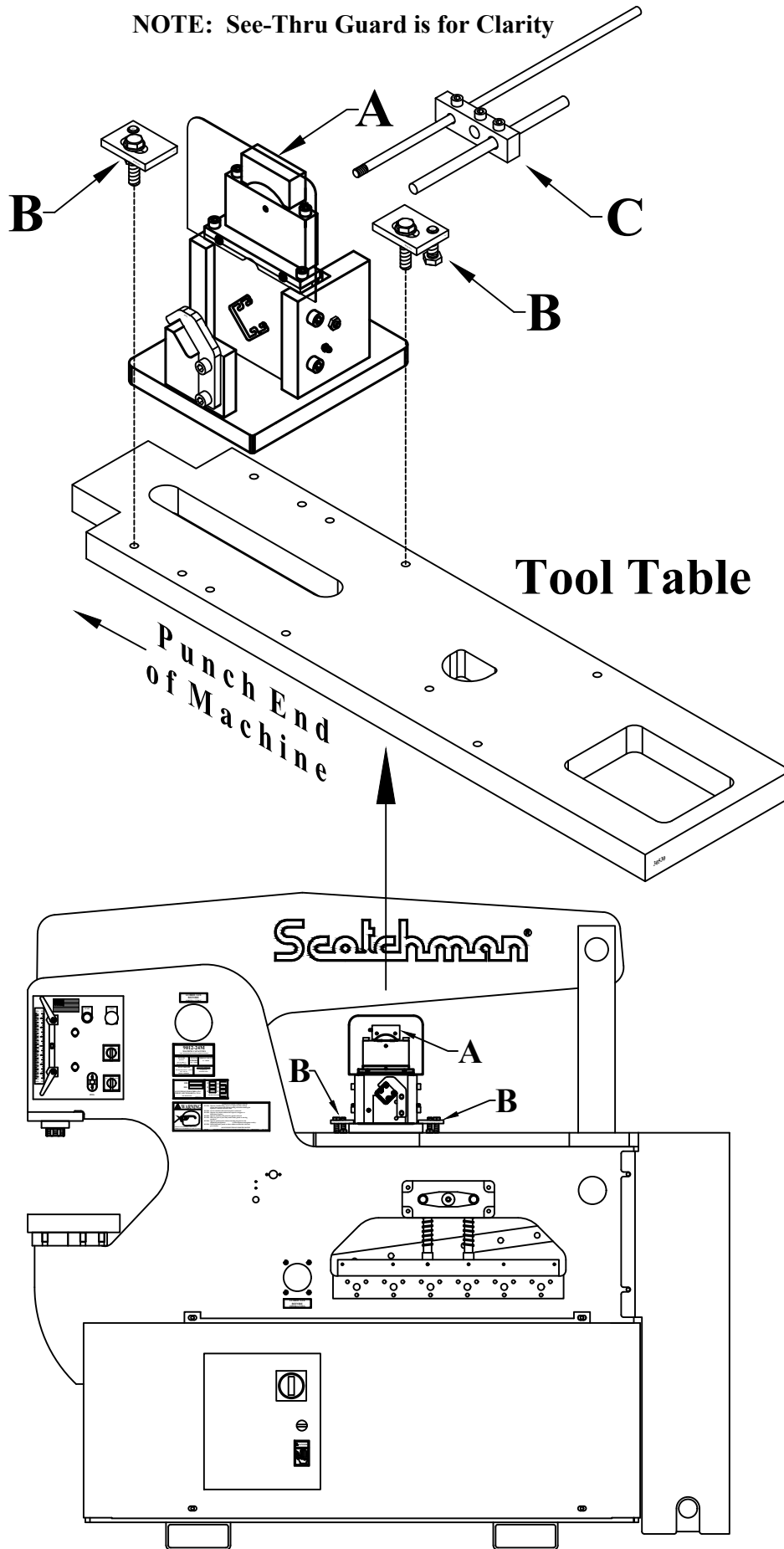
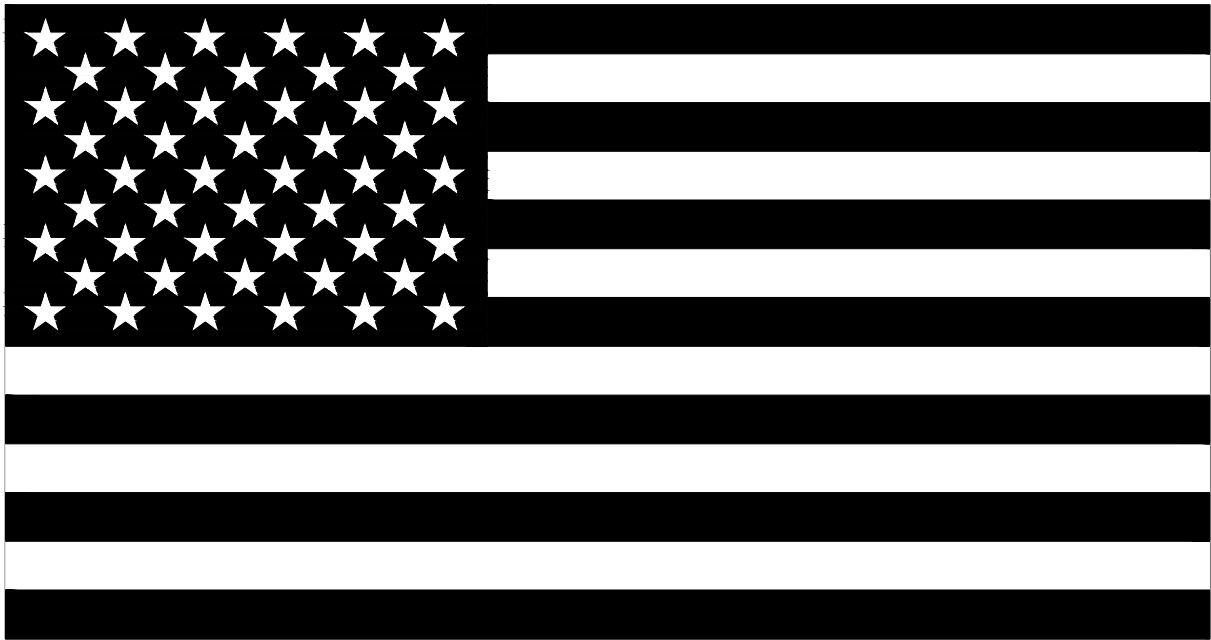

FIGURE 30



AMERICAN MADE



WWW.SCOTCHMAN.COM

8.0 TROUBLE SHOOTING GUIDE

8.1 ELECTRICAL TROUBLE SHOOTING - MOTOR

⊗ **CAUTION: ALL ELECTRICAL WORK PERFORMED ON THIS IRONWORKER SHALL BE DONE BY A QUALIFIED ELECTRICIAN.**

A. MOTOR WILL NOT RUN:

- 1. Check to be sure that the disconnect switch is in the ON position and that the selector switch is in the START position.**
- 2. Check to be sure that plant voltage and phase correspond to the machine voltage and phase.**
- 3. Check the line wiring connections at the starter. For the wiring diagrams, SEE SECTION 4.4**
- 4. Check the primary and secondary fuses on the transformer.**
- 5. Check the line voltage at the starter. If the correct line voltage is present at the starter, either the starter or the motor is defective. Contact your local dealer or the factory.**

B. MOTOR RUNS BUT THE MACHINE WILL NOT CYCLE WHEN DEPRESSING THE FOOT PEDAL:

- 1. Check the motor rotation. It should be counterclockwise when facing the shaft end of the motor.**
- 2. Check the selector switch. It must be in either the PUNCH or the SHEAR position or the machine will not move.**
- 3. Check the stroke control adjustment and make sure that only one limit switch is in contact with the metering boss. If both limit switches are in contact with the metering boss, the machine will not move. Loosen the stroke control handles and move the limit switches. Try the machine again.**
- 4. Check the fuses in the control box. There are two fuses in line on the primary side of the transformer and one on the secondary side. Remove the fuses and check them with an Ohm meter and replace them, if necessary. Use a Bussman FNQ-R1 600 volt or equivalent for the primary side. Use a Bussman FLM-1 6/10 or equivalent for the secondary side.**
- 5. Check the limit switches. SEE SECTION 8.2 for more information on how to do this.**
- 6. No power from the transformer: Check the voltage across the transformer's secondary terminals. It should read 110 to 120 volts.**
- 7. The solenoid on the control valve is not functioning: SEE SECTION 8.3 for more information.**
- 8. The foot pedal switch is not functioning properly: A voltage test may be run on the terminal strip in the control box to determine if the foot-switch is working properly.**

- ⤵ WARNING: THERE IS LINE VOLTAGE PRESENT IN THE CONTROL BOX WHEN THE MACHINE IS POWERED. THESE TESTS SHOULD BE PERFORMED BY A QUALIFIED ELECTRICIAN.**

TO TEST THE FOOT SWITCH, place the selector switch in the START position and power the machine. Place the selector switch in the PUNCH or the SHEAR position and test the voltage between terminal #'s x2 & 5 and x2 & 10. With the pedal up, the voltage should read 110-120V between #'s x2 & 5. There should be no voltage reading between #'s x2 & 10. With the pedal depressed, the voltage should read 110-120V between #'s x2 & 10. There should be no voltage reading between #'s x2 & 5. If these readings are not correct, continue on with the following steps:

- A. Turn the machine's power off at the disconnect switch. Remove the cover on the foot switch and check for any loose connections.**
- B. Make sure that the switches are adjusted properly. (You should hear two distinct "clicks" when depressing the pedal.) There is a set screw adjustment on the pedal shaft to adjust the switches.**
- C. Check the switches with an Ohm meter.**
- D. Damage to the foot pedal cord: Make sure that the power to the machine is off and locked out. The wires must be disconnected from the pedal and the terminal blocks. Check the continuity of the wire in the cord with an Ohm meter.**

8.2 LIMIT SWITCH INSPECTION

The limit switches are sealed units and cannot be taken apart. The plunger can be manually checked. It should move freely in and out. The switches can also be tested with an Ohm meter.

The wires must be disconnected from the terminal blocks and the power to the machine off.

With the plunger out, the switch should read continuity; with the plunger depressed, it should read open.

8.3 CONTROL VALVE INSPECTION

THE MACHINE WILL ONLY TRAVEL IN ONE DIRECTION.

THIS COULD BE CAUSED BY:

- A. Contamination in the hydraulic oil which causes the spool to stick in one position. With the machine's power off, the spool of the valve can be manually shifted. On each end of the control valve, there is a pin in the center of the knurled nut that holds the coil on. To shift the spool manually, use a small punch or similar device to push these pins in by hand, first one and then, the other.
Turn the machine on and try it again. If the machine now operates, the hydraulic oil and the filter should be changed.**
- B. A defective coil on the control valve: The coils can be checked by using an Ohm meter. The wires to the coils must be disconnected. If the ohm reading shows open, the coil is defective and must be replaced.**

8.4 HYDRAULICS

THE MOST COMMON HYDRAULIC PROBLEMS ARE:

- 1. Low level of hydraulic oil in the reservoir: The reservoir holds 13.5 U.S. gallons (51 Liters). The level should be 1" below the top of the reservoir.**
- 2. Contamination in the hydraulic oil: The oil and the filter should be changed at least once a year and any time there is a possibility that contamination has gained access into the system.**
Replace hydraulic oil with a lightweight, non-foaming, hydraulic oil such as Mobil DTE-25
- 3. Low pressure caused by worn or damaged parts in the cylinder or pump: There is a pressure port for a pressure gauge provided on all machines. The port will be on the valve manifold or the pressure line between the pump and the valve. A gauge with a minimum capacity of 3,000 PSI (207 BAR) is required.**
- 4. In order to check the machines hydraulic pressure, the hydraulic pressure relief valve must be in "bypass mode". This happens when the machine is "stalled out". Below explains how to do this:**
With the machine's power off, install the pressure gauge. Power the machine and put it in the Shear mode. Place a piece of thick steel in the shear section at the cylinder end of the machine and clamp it down with the hold down device. When attempting to shear the piece, the machine should stall and go into bypass mode. Watch the pressure gauge for a reading. The system pressure of this machine is 2,650 PSI (183 BAR). The pressure can be changed by adjusting the relief valve on the control valve manifold. If the pressure cannot be adjusted to 2,650 PSI, call your local dealer or the factory.

8.5 CYLINDER SEAL REPLACEMENT

Use the following steps to replace the seals in the hydraulic cylinder:

SEE FIGURE 31 ON THE FOLLOWING PAGE.

- 1. With the selector switch in the SHEAR position and the arms up, turn the machine's power off at the disconnect switch and lock it.**
- 2. Block the arms up, either on the tool table or under the shear arm. SEE ITEM A.**
- 3. Remove the hydraulic hoses from the cylinder and allow the oil to drain from the cylinder.**
- 4. Remove the cylinder clevis pin (C) and swing the cylinder out away from the arm.**
- 5. The cylinder head (B) is threaded into the cylinder.**
- 6. Use a pin wrench to unscrew the cylinder head from the cylinder tube.**
- 7. Place a rod through the cylinder clevis and pull the cylinder apart, using a come-a-long or similar device.**
- 8. Remove the locking nut from the end of the cylinder shaft and slide the piston and the head off of the shaft.**
- 9. Replace all of the seals. There will be extra seals in the kit. Match up the replacement seals with the old ones and discard the rest.**
- 10. Clean all of the parts, including the inside of the cylinder tube, and check all parts for nicks and scratches.**
- 11. Oil all of the seals before reassembling the cylinder.**
- 12. After the piston and head are assembled on the shaft, they can be tapped back into the tube with a brass or plastic hammer.**
- 13. Re-thread the cylinder head into the tube.**
- 14. Reconnect the hoses to the cylinder.**
- 15. Use care removing the blocking device (A) from under the arms. Since the cylinder does not contain oil, it may drop some when the blocks are removed.**
- 16. Cycle the machine several times to purge the air out of the hydraulic system.**

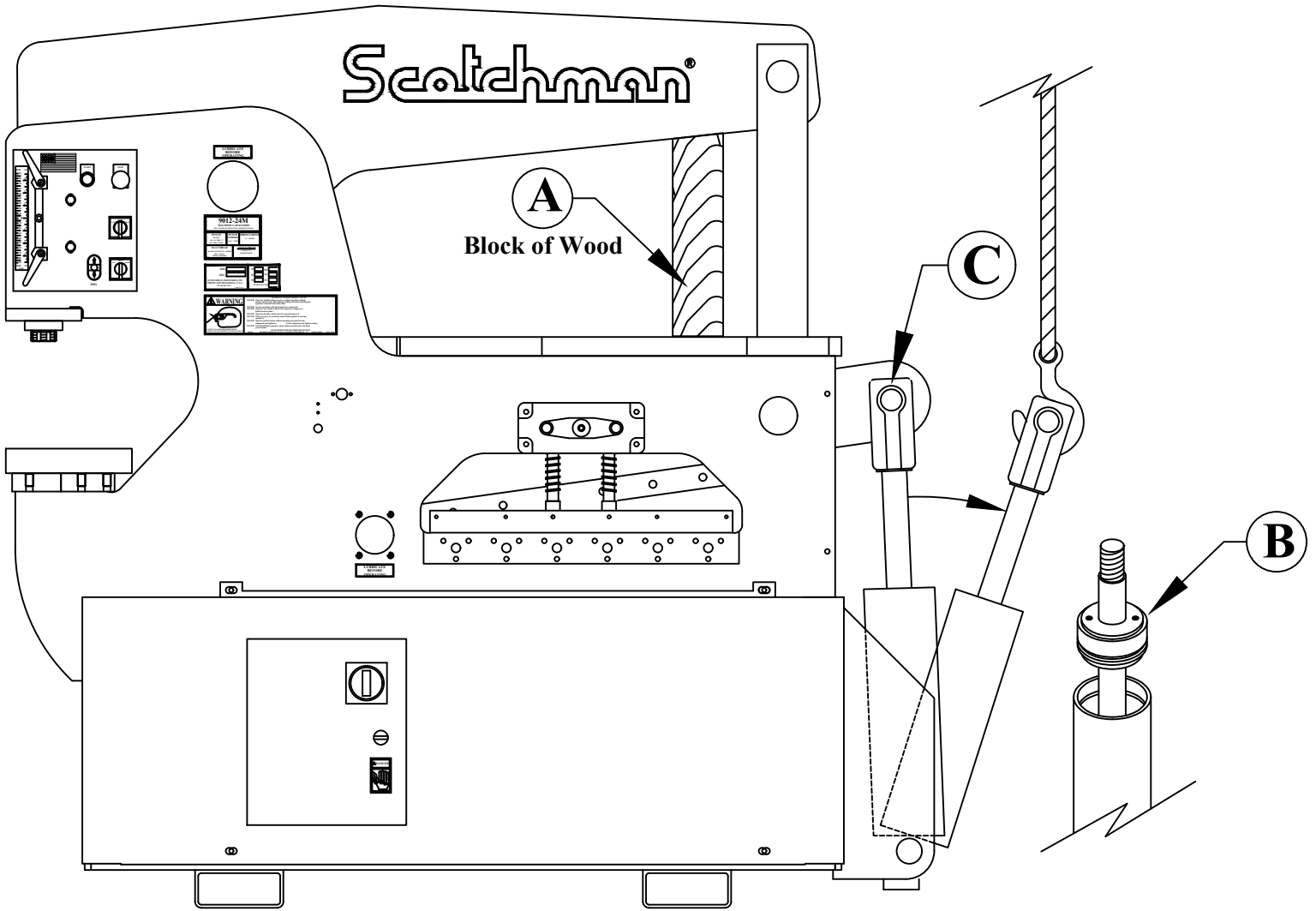

FIGURE 31

9.0 9012 IRONWORKER PARTS LISTS

FOR YOUR CONVENIENCE, ALWAYS GIVE YOUR COMPLETE SERIAL NUMBER
WHEN ORDERING PARTS.

9.1 SHEAR ARM ASSEMBLY (SER. # 21601M & UP)

ITEM	PART #	DESCRIPTION
A	030650	Rub Block
B	030550	Shear Arm (Includes C & G)
C	080169	Brass Bushings
D	080031	Upper Shear Blade
E	210014	M12 Jam Nut
F	080435	Shear Table
G	010182	Main Pin Bushing
H	030556	Shear Arm Pin
I	080174	Grease Bolt
J	012121	Pressure Plate
K	037273	Brass Plate (2 Required)
L	218120	M12 Set Screw
M	214014	M12 Washer
N	212014	M12 Lock Washer
O	218120	M12 Set Screw
P	205422	M12 HHCS
Q	221322	M12 SHCS
R	080428	Shear Slug Chute
S	030660	Tooling Slug Chute
T	201220	M10 HHCS
U	218112	M12 Set Screw
V	006015	Shear Arm Rub Plate
W	205425	M12 HHCS
X	013289	Rear Shear Door
Y	224005	M6 x 12 WLCS
Z	033175	Lower Blade
AA	230210	M10 x 30 FSHCS
BB	026618	Tee Nut (M10)
CC	026698	Rest Button

DD	220029
EE	025705
FF	080063
GG	210012
HH	212016
II	006190
JJ	224205

M-10 x 35 BHCS
 Guide - Finished
 RS/Jig Handle
 M10 Jam Nut
 M16 Lock Washer
 Lower Punch Pin - Metric
 M10 X 16MM WLCS

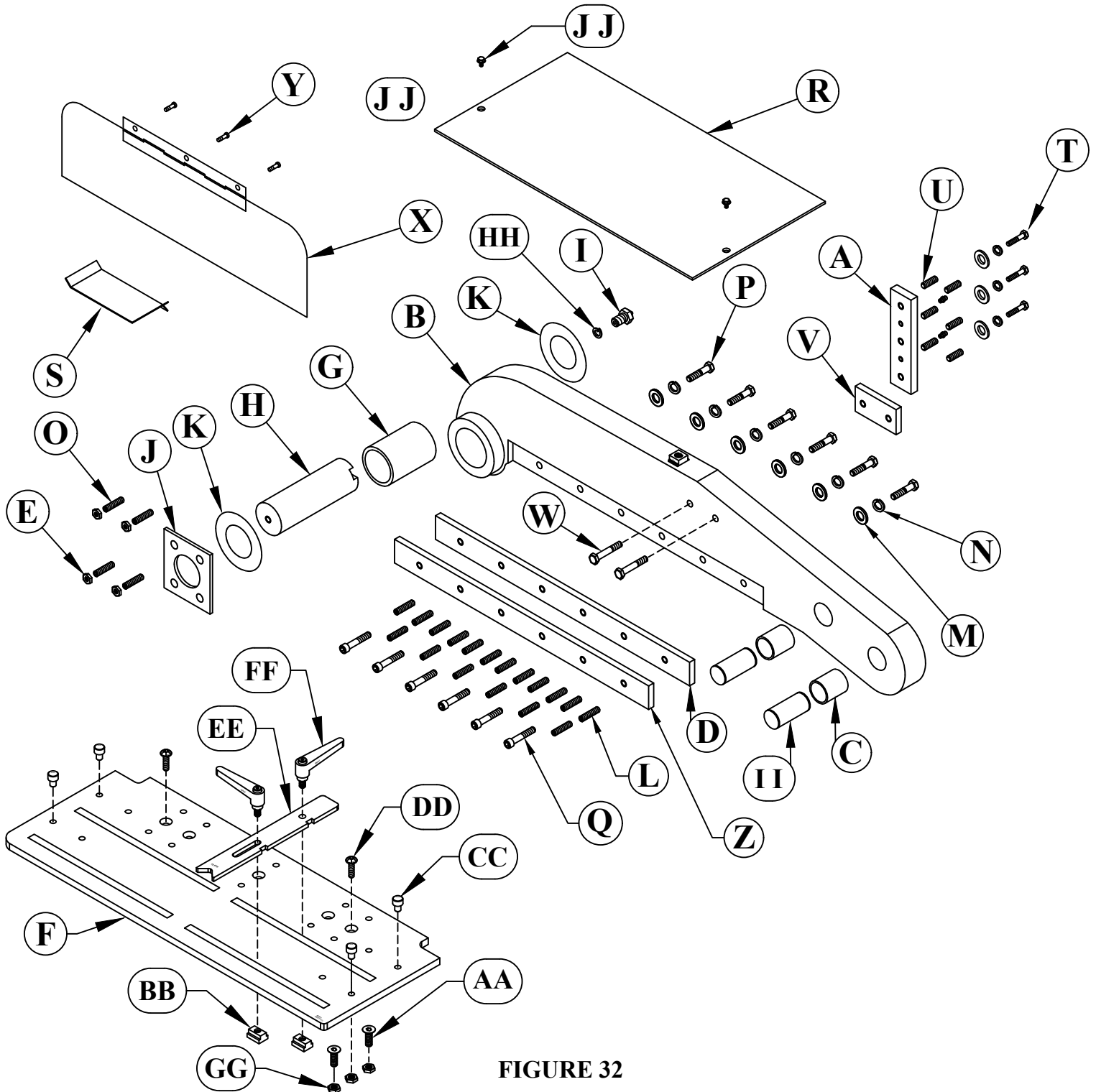

FIGURE 32

9.2 PUNCH ASSEMBLY

ITEM	PART #	DESCRIPTION
A	030640	Punch Bolster (Ser.# 21600 & Prior)
A1	080424	Punch Bolster (Ser.# 21601M & Up)
B	221420	M16 X 50MM SHCS
C	113017	1 3/4 OD X 21/32 ID Reid Washer
D	201625	M16 X 65MM HHCS
E	006013	Die Holder Metric (inc. F)
F	218058	M10 X 45MM DP SS
G	006202	#82 Metric Die Insert (inc. H, I, & J)
H	204220	M10 X 30 10.9 HHCS
I	026710	Punch Table With Scale 12"
J	230107	M8 X 16 FSHCS
K	016095	#40 XL Punch Retaining Nut
K1	016096	#45 Punch Retaining Nut
L	221315	M12 X 40MM SHCS
M&W	010236	Punch Ram & Bushing
N	036167	Lower Punch Pin
O	016620	2" Snap Ring
P	016625	2-1/2" Snap Ring
Q	032074	Upper Punch Pin & Bushing (Inc. P & U)
R	210014	M12 Jam Nut
S&T	030619	Punch Link Set (Includes CC & DD)
U	243101	M6 X 13.5 OAL Gold Zerk
V	201440	M12 X 100MM HHCS
W&M	010236	Punch Ram & Bushing
X	030657	Punch Shroud
Z	224205	M10 X 16MM WLCS
AA	077145	Hardened Pin
BB	004123	1/4" Key (All Key Punch)
CC	080192	2-1/2" Brass Spacer
DD	015131	2" Brass Spacers
EE	012078	3" Punch Holder (Includes GG)
FF	221120	M8 X 25 12.9 SHCS
GG	015033	Punch Ram Insert (Includes BB & HH)
HH	141010	3/16 x 1/2 Roll Pin
II	219060	M10 X 50 Set Screw
JJ	026618	Tee Nut
KK	026697	Guide Finished
LL	214012	M10 Regular Washer
MM	080063	XRS/Jig Handle

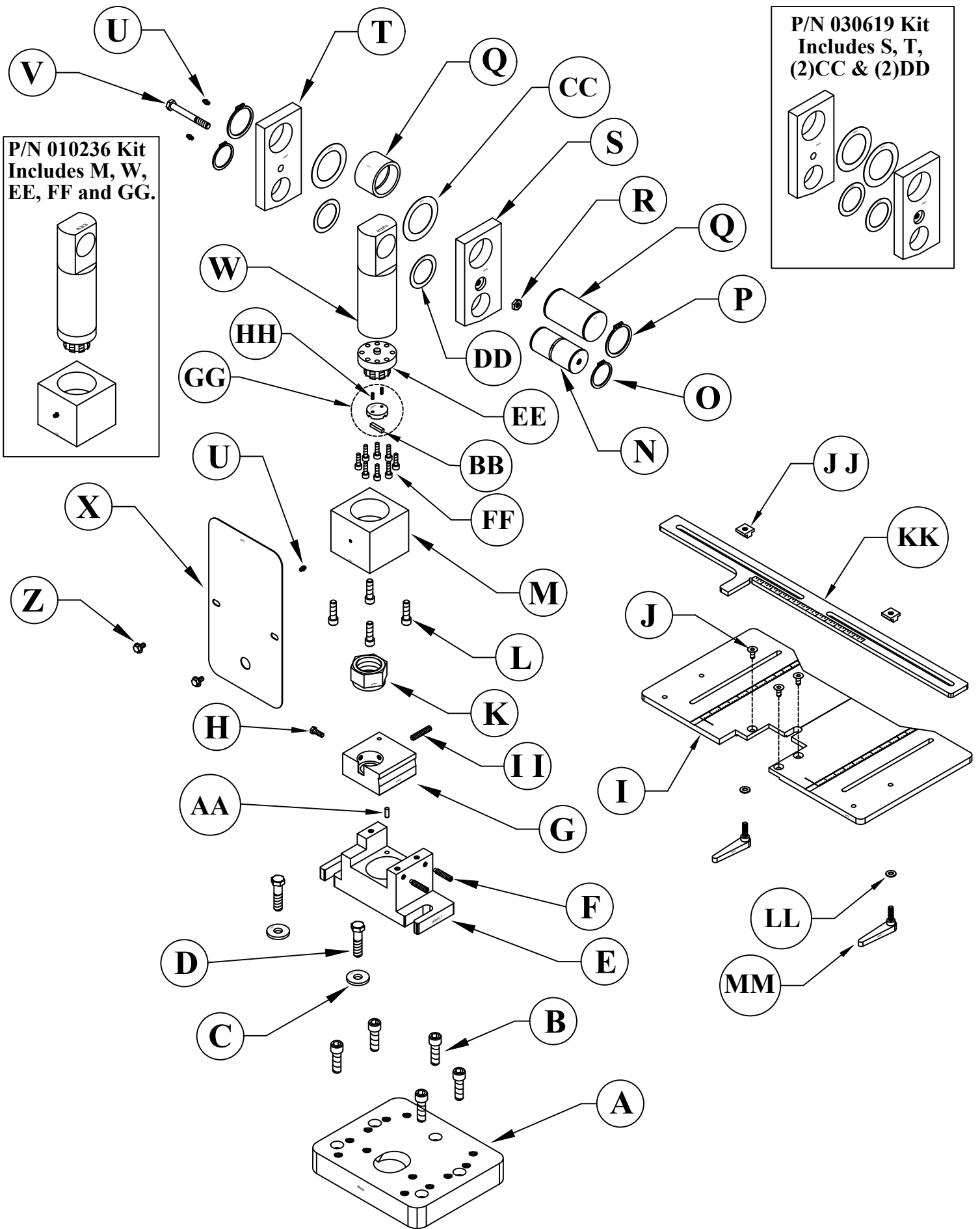

FIGURE 33

9.3 STRIPPER ASSEMBLY

ITEM	QTY	PART #	DESCRIPTION
A	1	007228	Stripper (Includes I & H)
B	1	007229	Adjustment Screw Stripper (Left)
C	1	007237	Hex Head Stripper Stud
D	1	007240	Spring Retainer
E	1	007241	Stripper Spring
F	1	007236	Adjustment Screw Stripper (Right)
G	1	007239	Spring Rod Stripper
H	2	220014	M-6 x 10MM BHNSCS
I	1	007268	Sight Glass (2-1/4 x 5)
J	1	007253	Stripper Plate Ass'y (Inc. M & N)
K	1	230007	M-6 x 16 FSHCS
L	1	007244	Stripper Retainer
M	1	001541	Ball Spring Screw
N	1	110014	1/2 x 13 Jam Nut
O	1	007233	Complete Stripper Assembly (Includes all items on this page.)

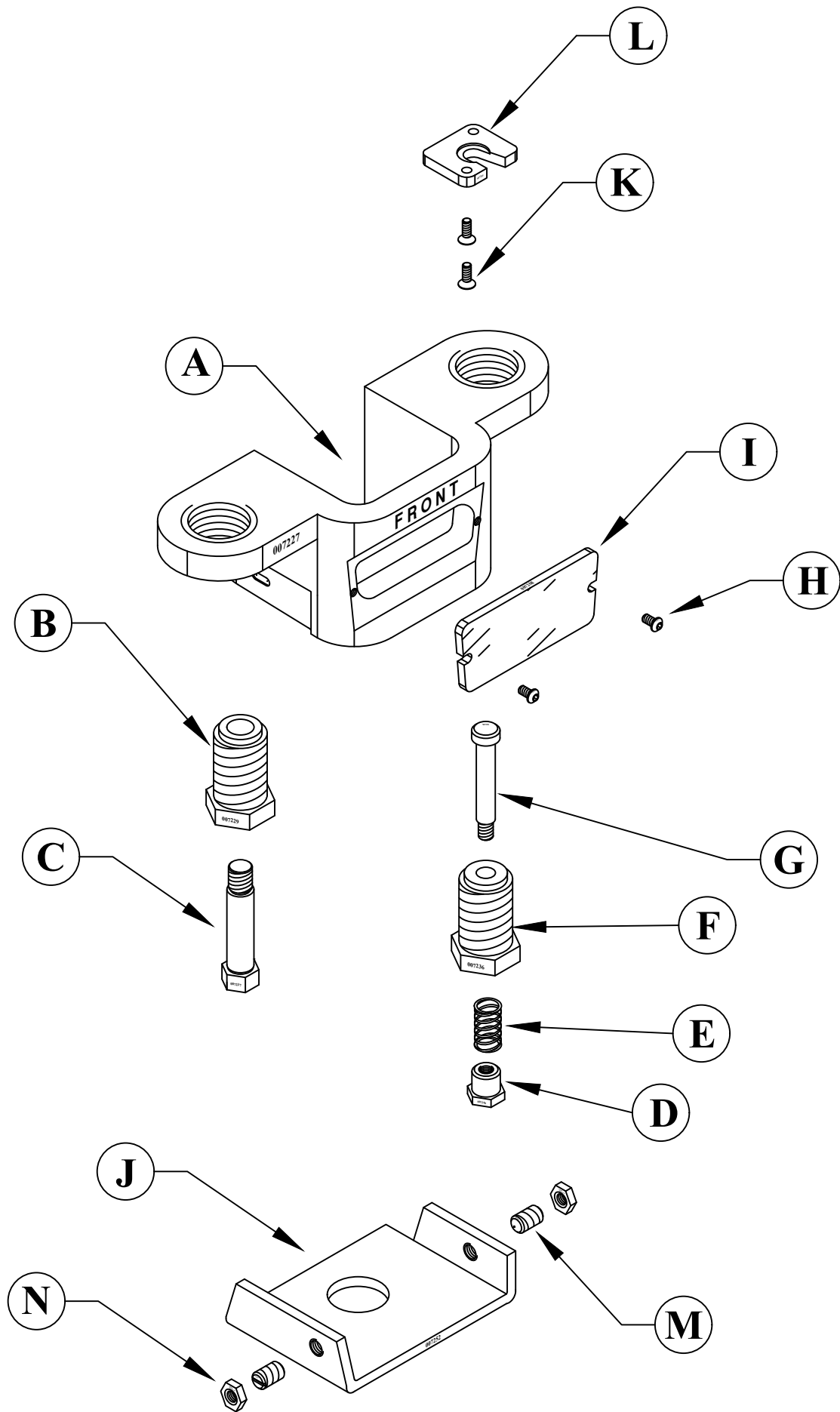

FIGURE 34

9.4 UPPER ARM ASSEMBLY

ITEM	PART #	DESCRIPTION
A	030560	Upper Arm (Includes A, B, D & F)
B	006172	Bushing
C	080174	Grease Bolt
D	012070	Upper Arm Bushing
E	030566	Upper Arm Pin (Inc. C & G)
F	032073	2 1/2" Snap Ring
G	212016	M16 Lock Washer
H	032073	Upper Punch Pin Bushing
I	030625	Upper Punch Pin
J	243101	M6 X 13.5 OAL Gold Zerk
K	032074	Punch Pin & Bushing (Includes: F, H, I, & J)

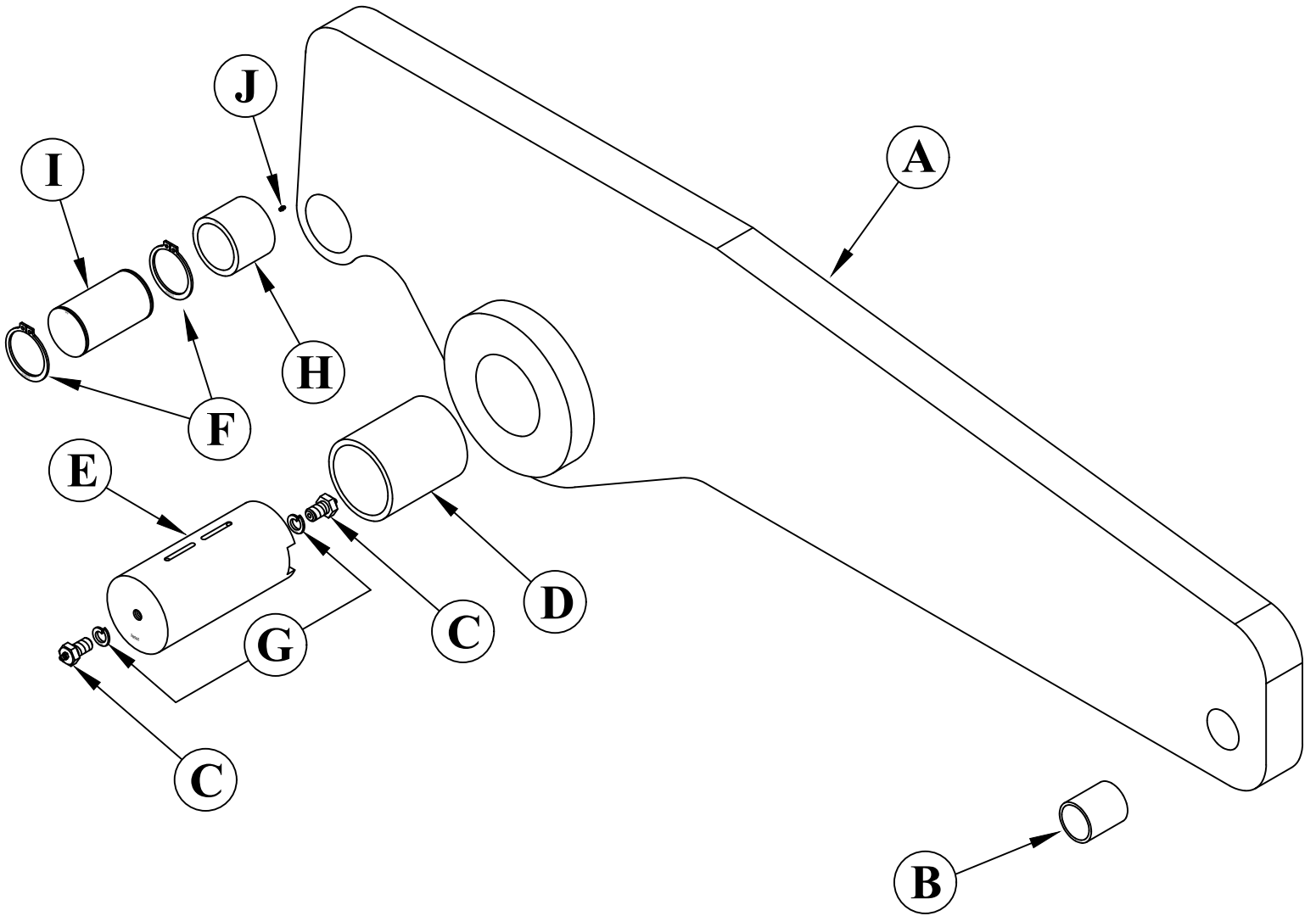
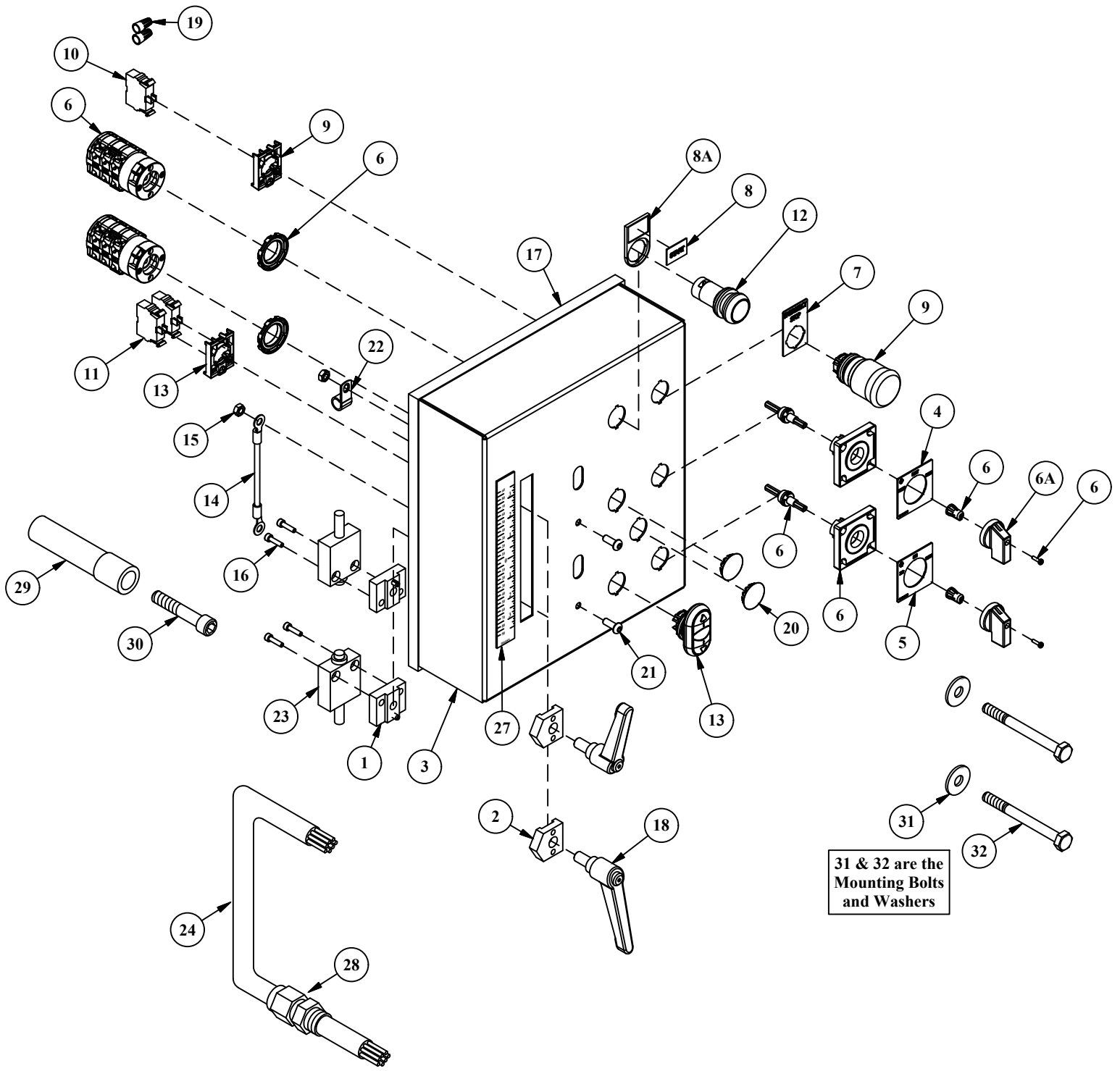

FIGURE 35

9.5 UPPER PANEL & STROKE CONTROL

ITEM	QTY	PART #	DESCRIPTION
1	2	004086	Micro Switch Mount
2	2	004087	Pointer Rev. A
3	1	007711	Sales Stroke Cover
4	1	011210	Legend Punch/Start/Shear K&N
5	1	011211	Legend Jog/Run/Probe K&N
6	2	011222	Cam Switch XL K&N
6A	1	011225	Cam Switch Knob-Kraus & Naimer
7	1	011500	Legend Stop
8	1	011509	Legend Start
8A	1	004521	Legend Plate Holder
9	1	011862	E-Stop Operator Pkgd. W/ 11872
9A	1	011837	E-Stop Switch Ass'y (Includes. 9 & 10)
10	1	011867	Contact M22-K01
11	2	011874	Contact Element
12	1	011879	Start Button
13	1	011886	Jog Push Button Pkgd. W/ 11872
13A	1	011884	Jog Button Ass'y (Includes 11 & 13)
14	1	011912	Ground Wire Ass'y
15	2	073206	M6 DIN934 Hex Nut
16	4	073450	M4 X 16MM DIN912 SHCS
17	46	077907	Shroud Edge
18	2	080061	Stroke Adjustment Handle
19	2	145005	Small Blue Wire Nut
20	2	158101	7/8 Steel Hole Plug
21	2	220020	M6 X 16MM ISO 7380 BHCS
22	1	562040	Wire Cable Clamp
23	2	562113	M.S. Limit Switch
24	85	660457	18/12 Cable (19015)
25	35	660470	16GA Black MTW Wire (not shown)
26	3	660505	Black Nylon Cable Tie (not shown)
27	1	004085	Scale - Stroke Control
28	1	562501	PG16 Liquid Cord Conn
29	1	080309	Metering Boss (Old Style - 3-1/8" Long)
29A	1	033178	Metering Boss (New Style - 5" Long)
30	1	221327	M12 x 70 SHCS
31	2	213012	M10 Black Washer
32	2	201240	M10 X 110MM HHCS
33	1	007710	Stroke Control 65/90/120



NOTE:
 #28 is located in the
 electrical enclosure
 in the base.

31 & 32 are the
 Mounting Bolts
 and Washers

FIGURE 36

9.6 HOLD DOWN ASSEMBLY

ITEM	PART #	DESCRIPTION
A	013185	Guard
B	080342	Housing
C	080337	Post-Left
D	080336	Post-Right
E	017340	Key 7 x 7 x 24
F	080347	Gear-Left
G	003105	Warning Label
H	080348	Gear-Center
I	080349	Gear-Right
J	080338	Wheel Shaft
K	080344	Base
L	201110	M6 x 12 HHCS
M	141415	1/4 x 1-3/4 Roll Pin
N	017342	Hold-Down Crank (Includes 2 each O, P & Q)
O	210014	M12 Jam Nut
P	017347	Handle
Q	221335	M12 x 80 SHCS
R	221120	M8 x 25 SHCS
S	080339	Wheel Washer
T	221320	M12 x 50 SHCS
U	212014	M12 Lock Washer
V	017341	Complete Hold Down

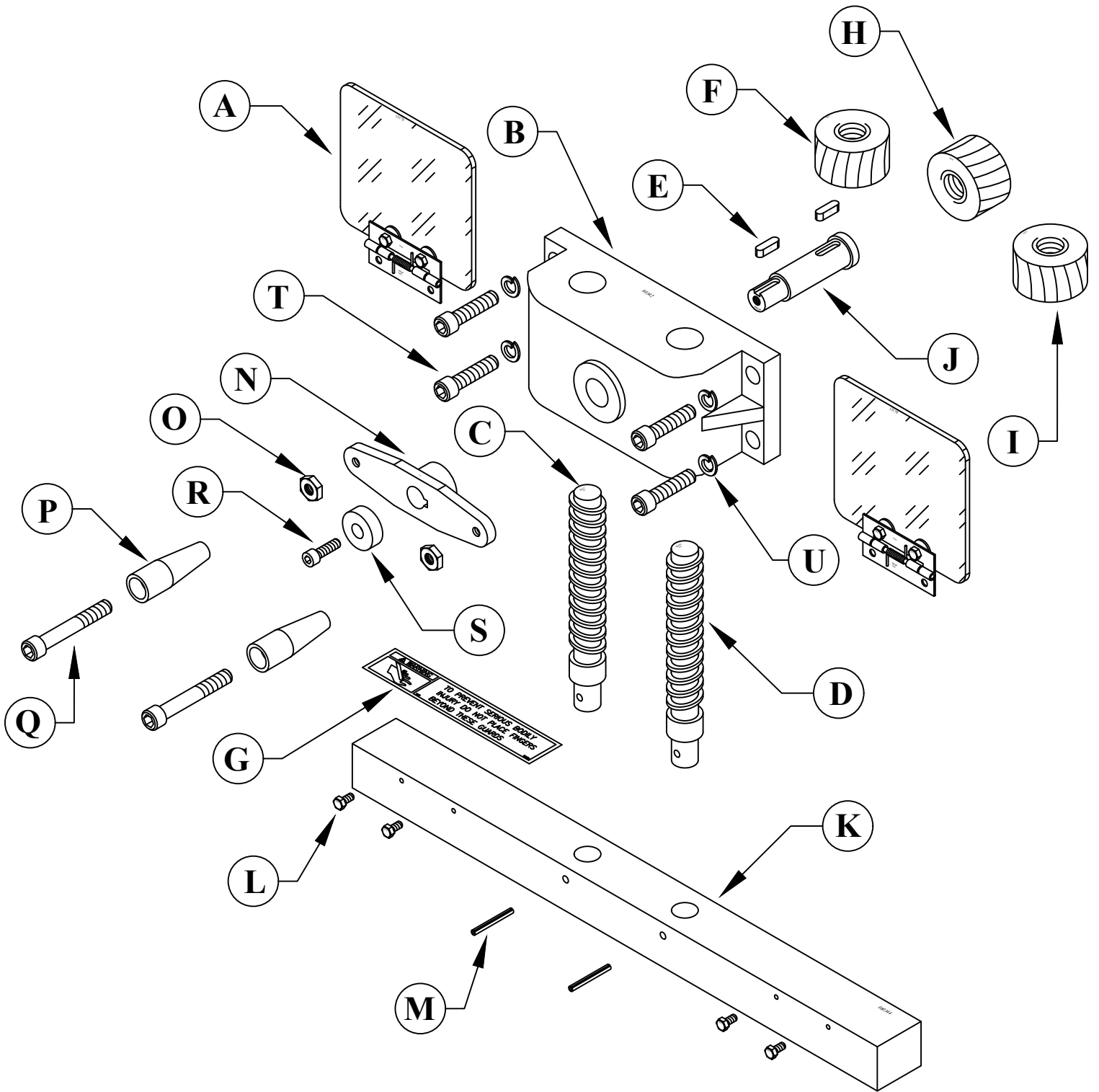

FIGURE 37

9.7 CYLINDER ASSEMBLY AND SHROUDS

ITEM	PART#	DESCRIPTION
A	006190	Clevis Pin
B	030580	Cylinder Clevis
C	030605	Cylinder (Includes B)
D	030595	Cylinder Anchor Pin
E	016620	2" Snap Ring
F	030233	Cylinder Shroud
G	224205	M10 WLCS
H	030631	Rear Shroud - Ser. # 20600M & Prior
H-1	080423	Rear Shroud - Ser. # 20601M & Up
I	030637	Front Shroud - Ser. # 20600M & Prior
I-1	080422	Front Shroud - Ser. # 20601M & Up
J	030610	Cylinder Seal Kit (Not Pictured)

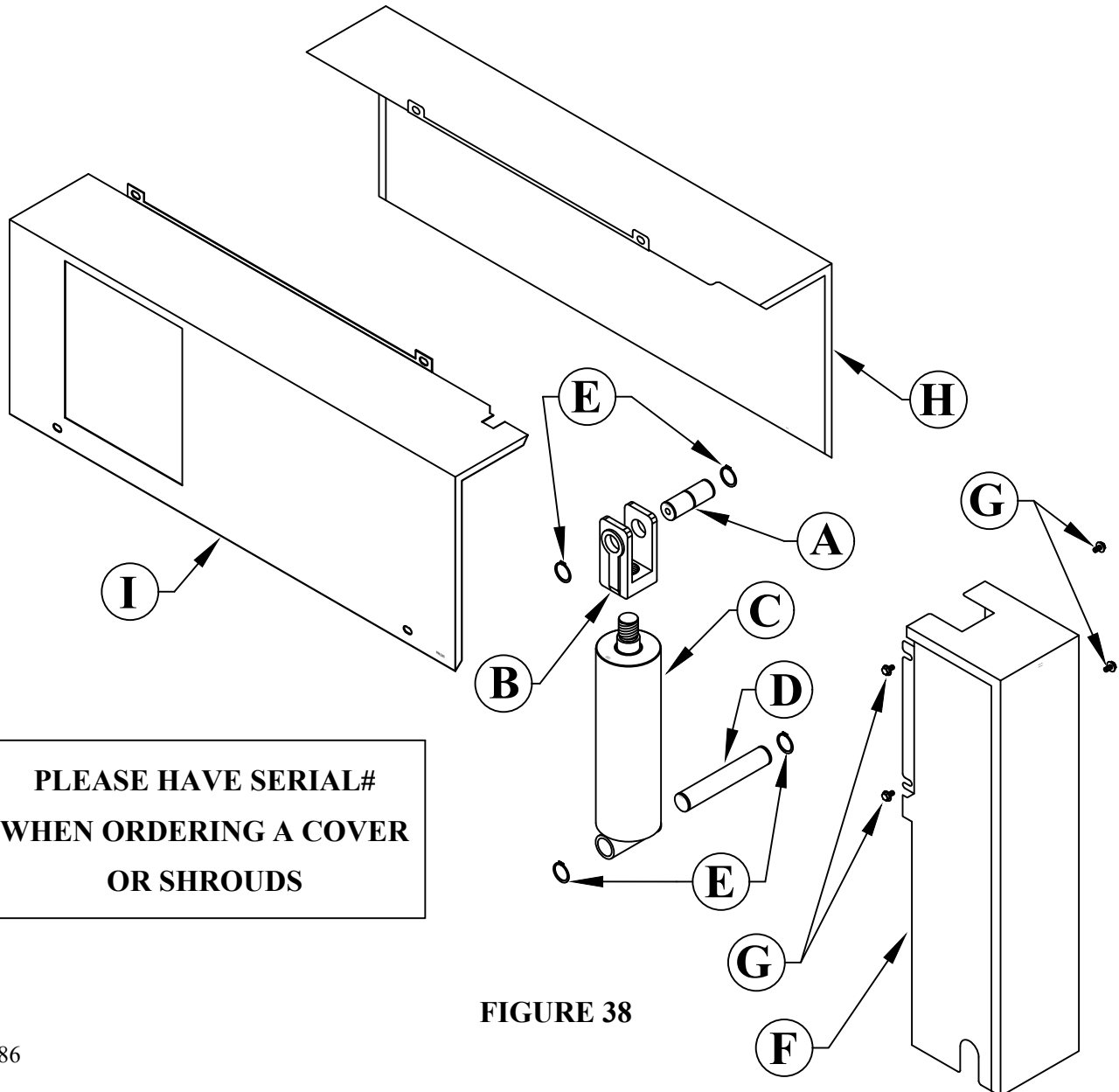

FIGURE 38

9.8 CONNECTING LINK ASSEMBLY

ITEM	PART#	DESCRIPTION
A	030570	Connecting Link
B	006190	Connecting Link Pins
C	016620	2" Snap Ring
D	243101	M-6 Grease Zerk

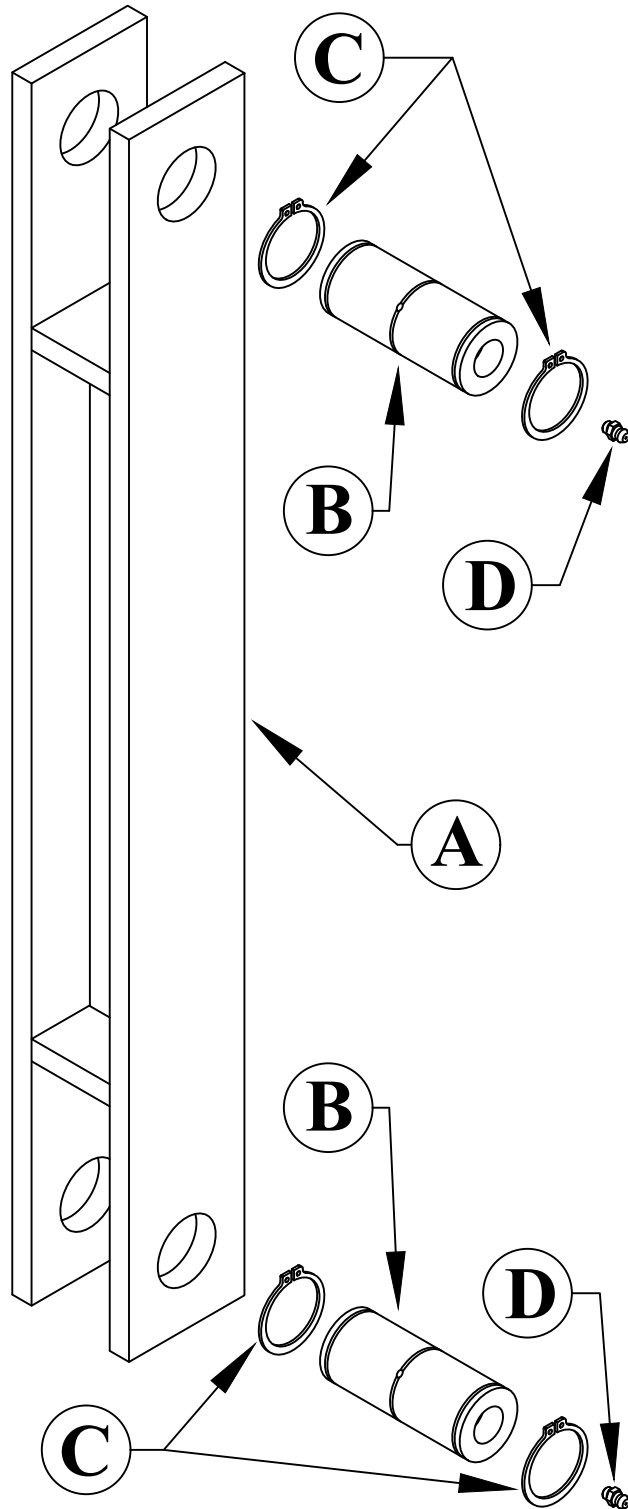

FIGURE 39

9.9 POWER UNIT - S/N 20661M & UP

ITEM	PART #	DESCRIPTION
A	006860	Filter (Ser.#'s 21772M0613 & Prior)
A1	006863	Filter (Ser.#'s 21773M0613 & Up)
A2	006875	Filter Housing
B	N/A	Fitting
C	006840	Return Hose
D	016088	Filler Breather Cap
E	017105	1" Close Nipple (Obsolete)
F	003810	1" SAE Ball Valve
G	N/A	Fitting
H	006830	Suction Hose
I	N/A	Fitting
J	Per Machine	Shaftless Motor (Must Specify - See Below)
	006915	230V 1PH Motor Assy.
	006905	208/230V 3PH Motor Assy.
	006910	460V 3PH Motor Assy.
K	007340	Pump
K1	007344	Marzocchi Pump Seal Kit (Old Models) Model PD2AD20AC & 2D20-P216
K2	007342	Marzocchi Pump Seal Kit (New Models) Model GPHC2A-D20/20-P606
L	006960	Vibration Dampener
M	003952	12MJ - 12MB90 Adaptor
N	006835	Pressure Hose
O	N/A	Fitting
P	N/A	Manifold Mounts
Q	006870	Manifold w/Valve & Coils
Q1	006872	Manifold
Q2	006865	Relief Cartridge
R	552135	Sales Valve Assembly
R1	552180	Valve (Includes 552181 Coils.)
R2	552181	Coil (For 552180)
S	N/A	Fitting
T	N/A	Hyd. Reservoir
U	158050	Square Head Plug
V	003780	90/120 Cylinder Hose 32" OAL
W	003780	90/120 Cylinder Hose 32" OAL
X	006850	Inlet Strainer - Not shown.
Y	016089	1" 90 Degree Street Elbow

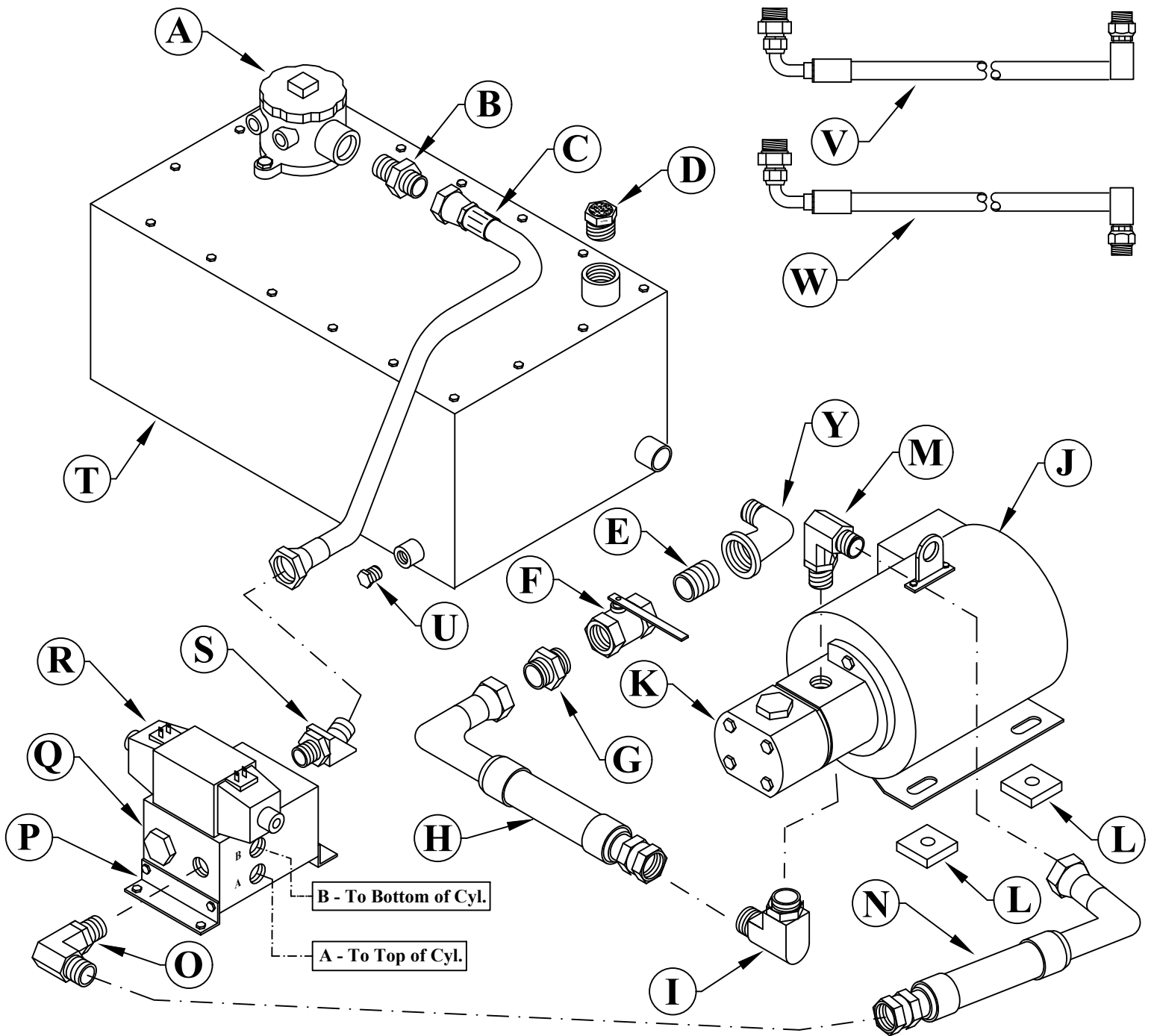

FIGURE 40

9.10 ELECTRICAL UNIT

ITEM	PART #		DESCRIPTION
	DIL	DIL-M	
A		011930	Transformer 150VA (S/N 21749M and prior) (above will work with LED light kit)
		011861	Transformer 250VA (S/N 21750M and up)
B		011933	Primary Fuse
C		011835	Secondary Fuse
D			Coil
E		562453	Foot Switch
		011753	Cord (Foot Switch)
		562451*	Micro Switch for <u>SSC Foot Pedal</u>
		562452*	Micro Switch for <u>Linemaster Foot Pedal</u>
F		011854	Disconnect Switch
FA		011895	Disconnect Switch Knob
G	See note.	011975	Contact (DIL-M) w/120V Coil
H	See note.	011999	Overload (230 Volt 3ph & 1ph)
	See note.	011998	Overload (460 Volt)
	See note.	011998	Overload (575 Volt)
I	011873		Start Switch Lamp
J	060083		Aux. Contact

* **BEFORE ORDERING A MICROSWITCH:** Inspect foot pedal to determine if it's a LINEMASTER or SSC.

► **NOTE:** If we are out of stock with the DIL (old style) contactor or overload, both the DIL-M (new style) contactor and overload must be purchased together as the old style and new style are not interchangeable.

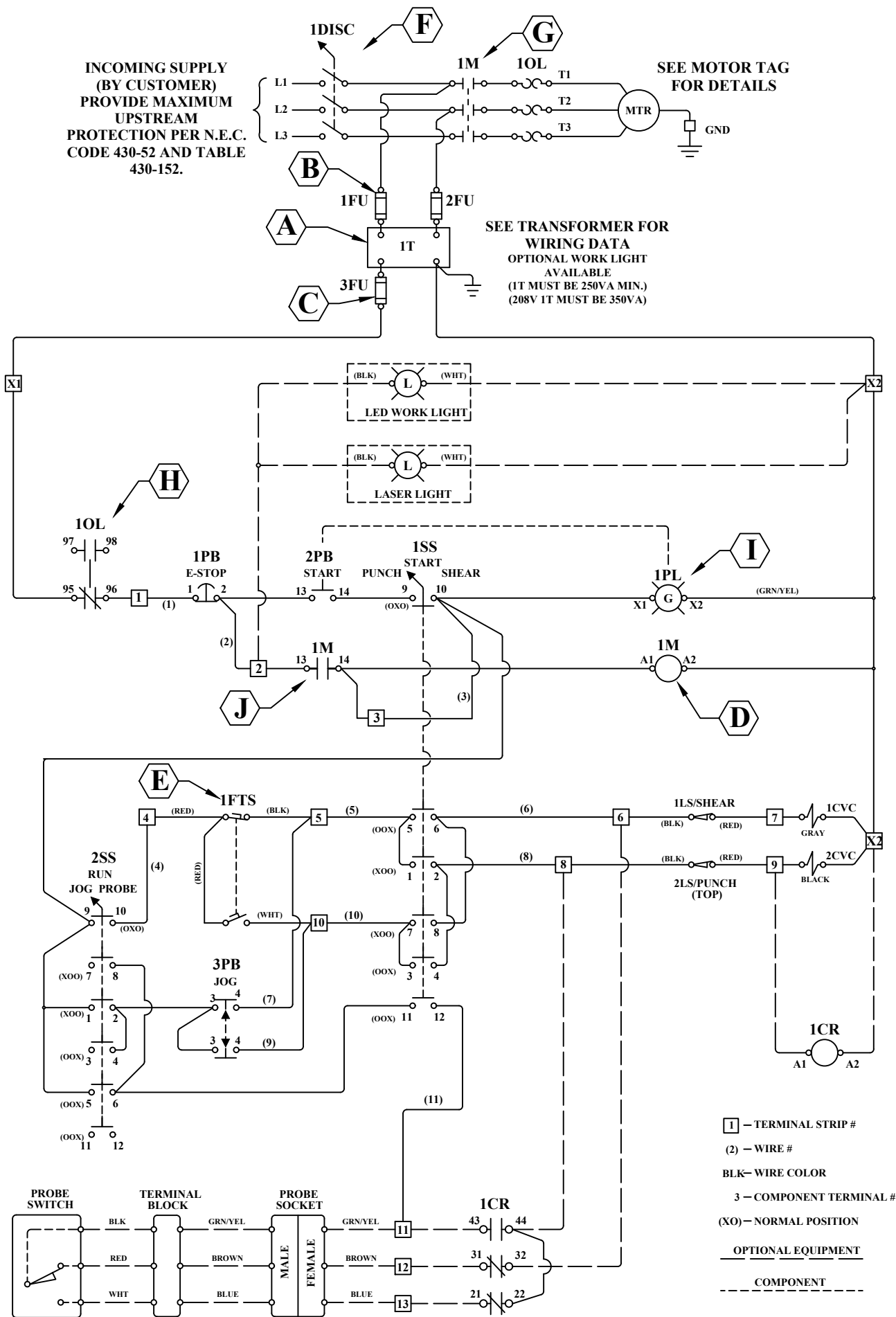

FIGURE 41

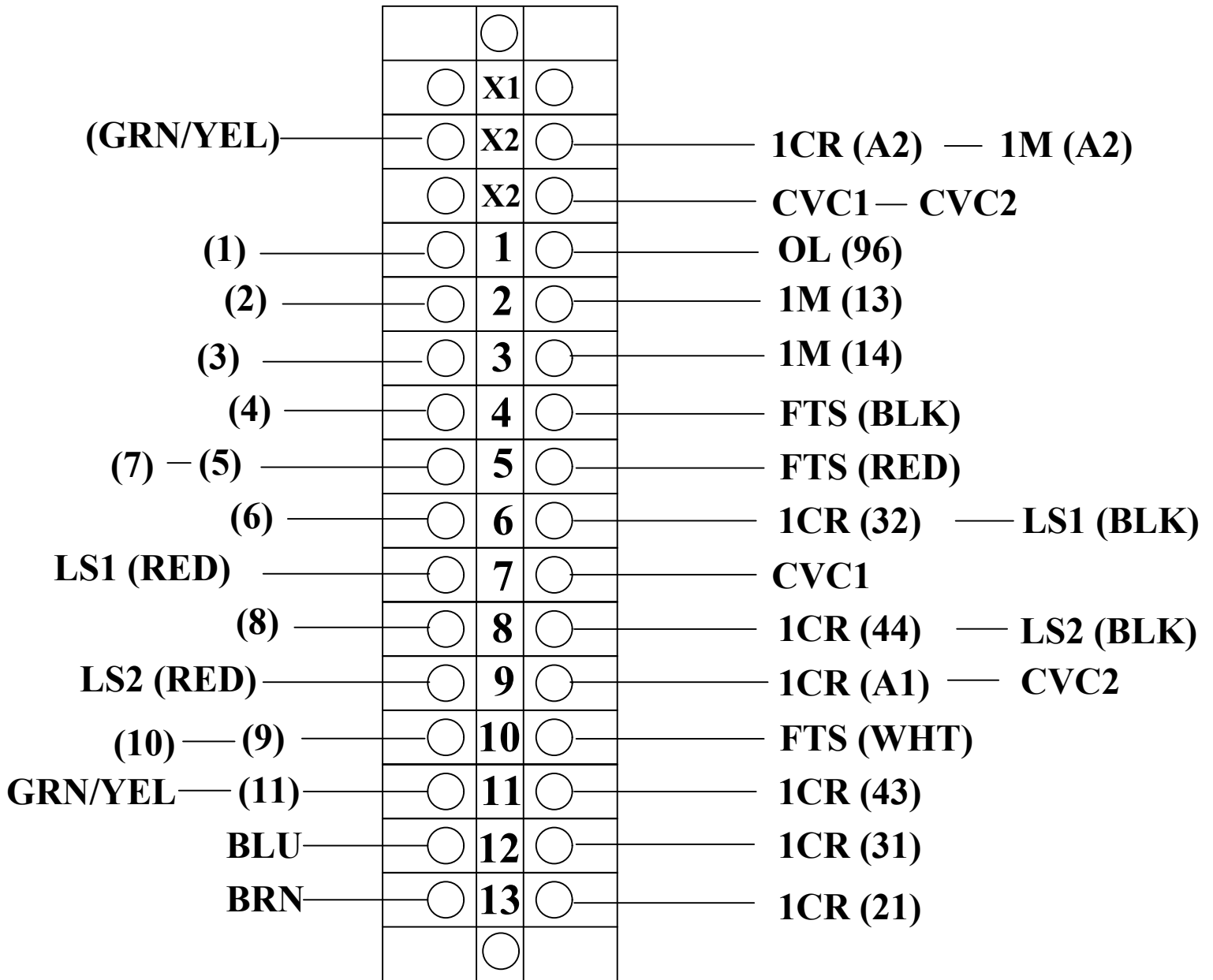
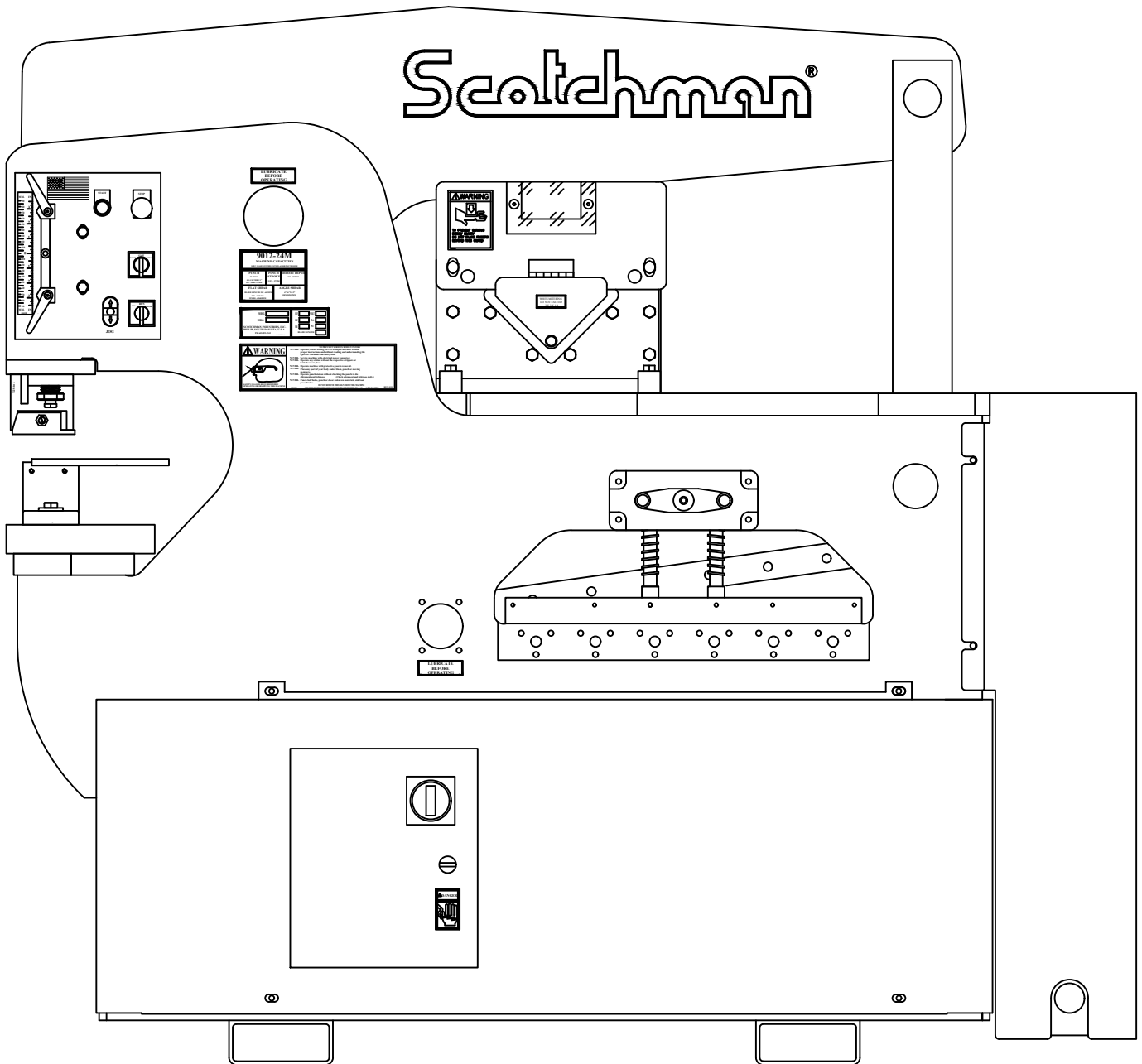

FIGURE 42

Scotchman

9012-24M IRONWORKER



AMERICAN MADE

9.11 URETHANE STRIPPER

ITEM	PART #	DESCRIPTION
1	025443	Post Retainer
2	025450	Lexan Shield
3	025455	Urethane Spring
4	025454	Spring Post
5	025456	Spring Spacer
6	025453	Post Nut
7	025451	3" Stripper Top Plate
8	073691	Knob
9	221329	M12 x 70 SHCS
10	218056	M106 x 30 Stainless SS
11	025447	Stripper Plate
12	026038	Die Holder .983"
	026030	3" Urethane Stripper Assy.
13	026042	Bolster (Ser. #21601 & Up)
13A	026043	Bolster (Ser. #21600 & Prior)
14	220014	M6 x 10 BHCS
15	026082	Stripper Guard
16	026060	Urethane Stripper Kit (9012) S/N 21658 and UP
16A*	026060*	Urethane Stripper Kit (9012) <u>*S/N 21601- S/N 21657 - SEE NOTE BELOW</u>
17	026065	Retro Fit Kit (S/N 21600 & Prior) Must also Purchase P/N 010236

*** NOTE: S/N 21601 thru S/N 21657 - MUST ALSO PURCHASE P/N 010236**

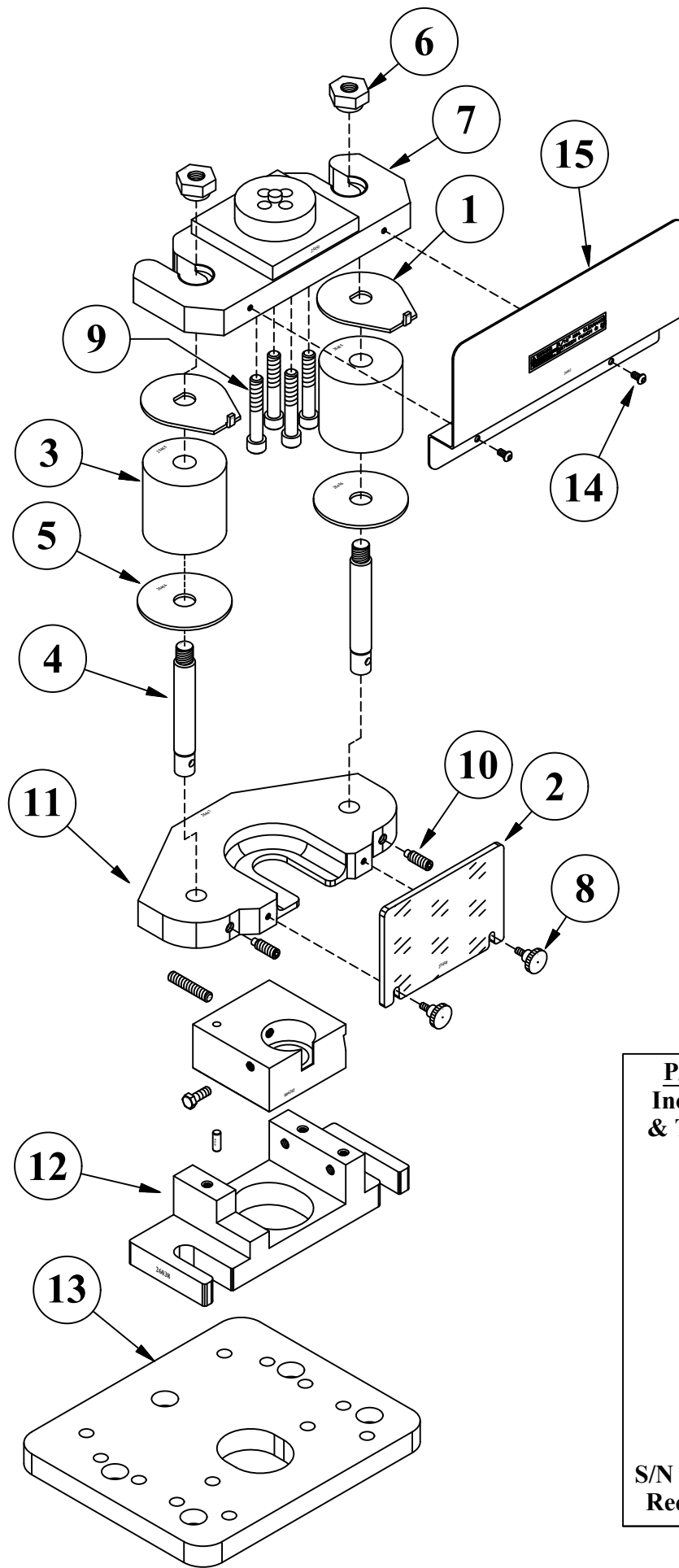

FIGURE 43

10.0 SUPPLEMENT FOR OLDER MODELS

10.1 SHEAR ARM ASSEMBLY (SERIAL #'S 21600M & PRIOR)

ITEM	PART #	DESCRIPTION	ITEM	PART #	DESCRIPTION
A	030650	Rub Block	N	230207	M-10 FSHCS
B	030550	Shear Arm	O	221417	M-16 SHCS
C	080169	Brass Bushings	P	205425	M-12 HHCS
D	080031	24" Shear Blades	Q	221322	M-12 SHCS
E	006250	Lower Blade Holder	R	080310	Shear Slug Chute
F	007100	Shear Table	S	030660	Tooling Slug Chute
G	010182	Main Pin Bushing	T	204222	M-10 HHCS
H	030555	Shear Arm Pin	U	218112	M-12 Set Screw
I	080174	Grease Bolt	V	006015	Shear Arm Rub Plate
J	012121	Pressure Plate	W	201432	M-12 x 80 HHCS
K	037273	Brass Shim 9012 (2 Required)	X	218122	M-12 x 60 Set Screw
L	218120	M-12 Set Screw	Y	210014	M-12 Jam Nut
M	210014	M-12 Jam Nut	Z	013289	Shear Door Assy.
			AA	224005	M-6 x 12 WLCS

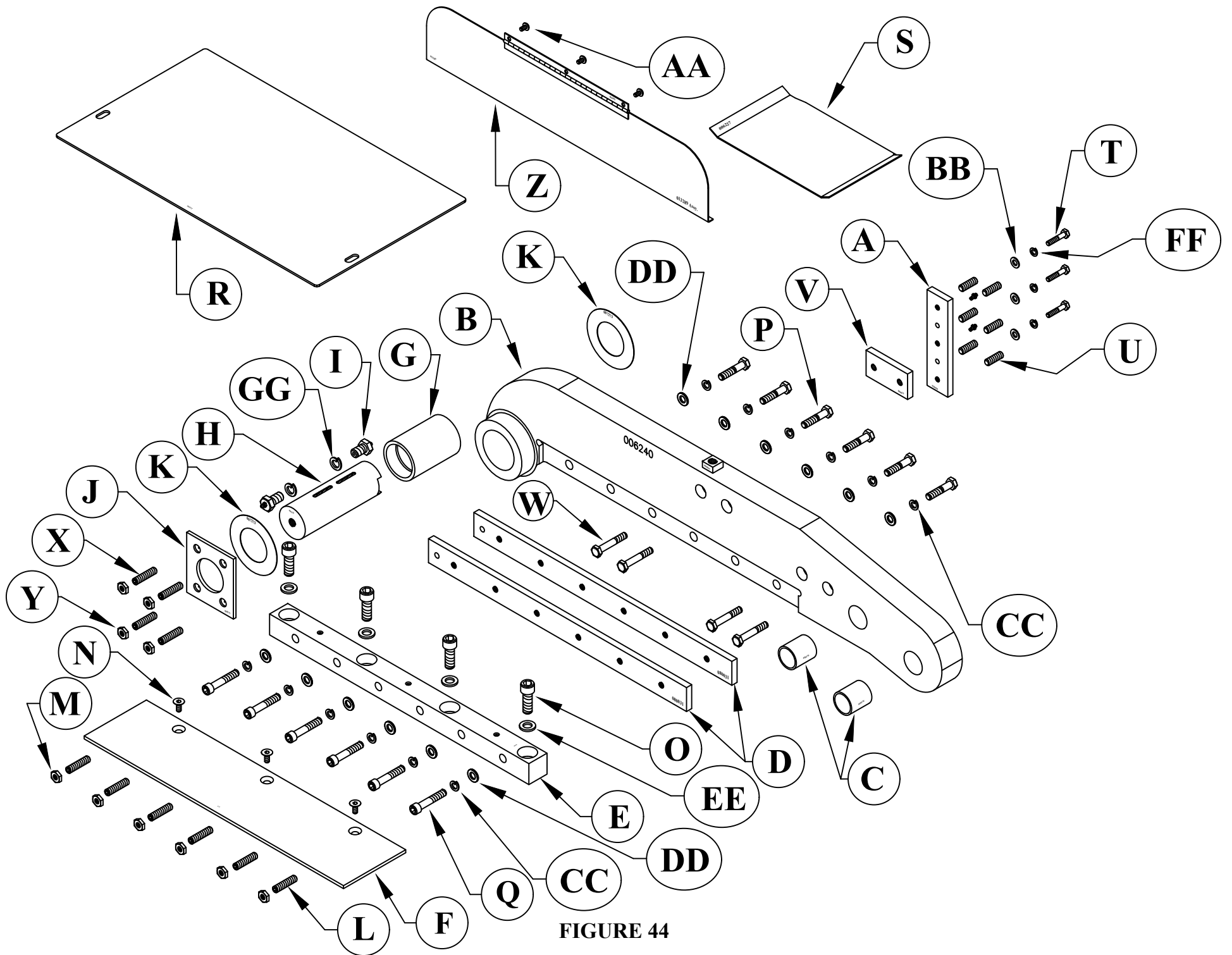

FIGURE 44

10.2 SHEAR BLADE ADJUSTMENT PROCEDURE

(SERIAL #'S 21600M & PRIOR)

SEE FIGURE 47 ON THE FOLLOWING PAGE.

1. Remove the shear table (K) and unlock the lock nuts on the back-up screws (E).
2. Loosen the four (4) socket head retaining screws (D) that hold the lower blade support (C) to the top of the shear bed and remove the blade and the lower blade holder.
3. Lower the shear arm to the DOWN position. Replace the shear blade and the lower blade support. Place a business card or shipping tag (approximately .010 in. thick) between the blades, one at each end of the blades and one in the middle. Hold the blades firmly together and partially tighten the (4) socket head retaining screws (D) that hold the lower blade support (C) in place. Adjust the back-up screws (E) firmly against the lower blade support (C). (Do not tighten so as to compress paper shims between the blades.) Tighten the (4) socket head retaining screws (D) to approximately 100 ft.-lbs. torque and lock the back-up screws (E) with the lock nuts.
4. Raise the shear arm and then LOWER IT SLOWLY, WATCHING THE BLADE ENGAGEMENT. MAKE SURE THAT THE BLADES DO NOT COME IN CONTACT WITH EACH OTHER.
5. This adjustment will give a blade clearance of .005 to .010 thousandths of an inch (.12 to .25mm). If the machine is being used to shear thicker sections of plate (1/2 inch (12mm) or thicker), we recommend increasing the clearance. A clearance of 5 to 7 percent of the material thickness is recommended. FOR RECOMMENDED CLEARANCES, SEE THE CHART AT THE BOTTOM OF THIS PAGE.
6. Replace the shear table (K). KEEP THE SHEAR SECTION CLEAR. Small slivers, short cuts, etc. should be removed from the slug chute, to prevent build-up. Build-up of short cuts can result in damage to the machine and POSSIBLE INJURY to other personnel.

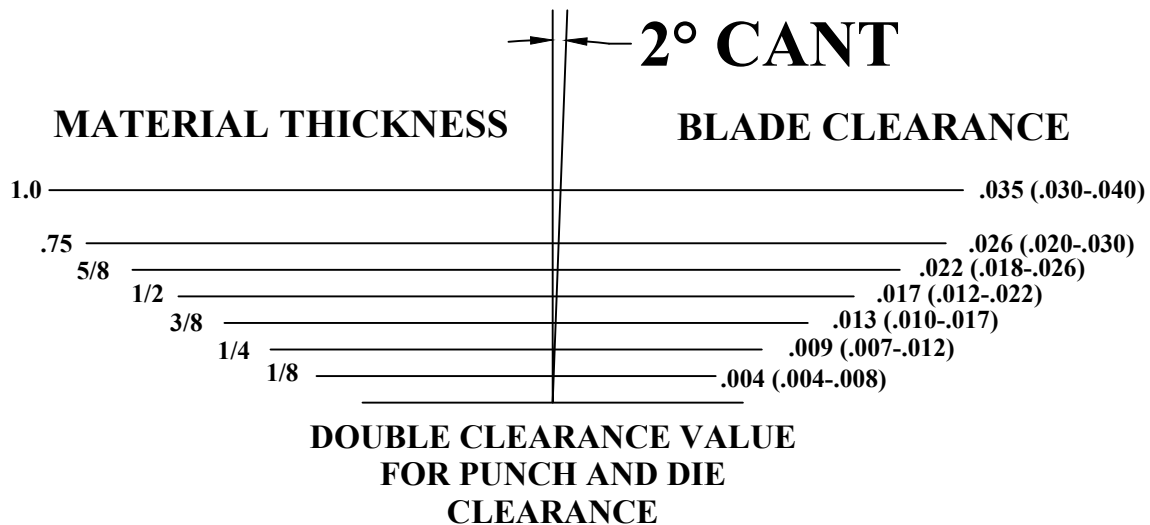

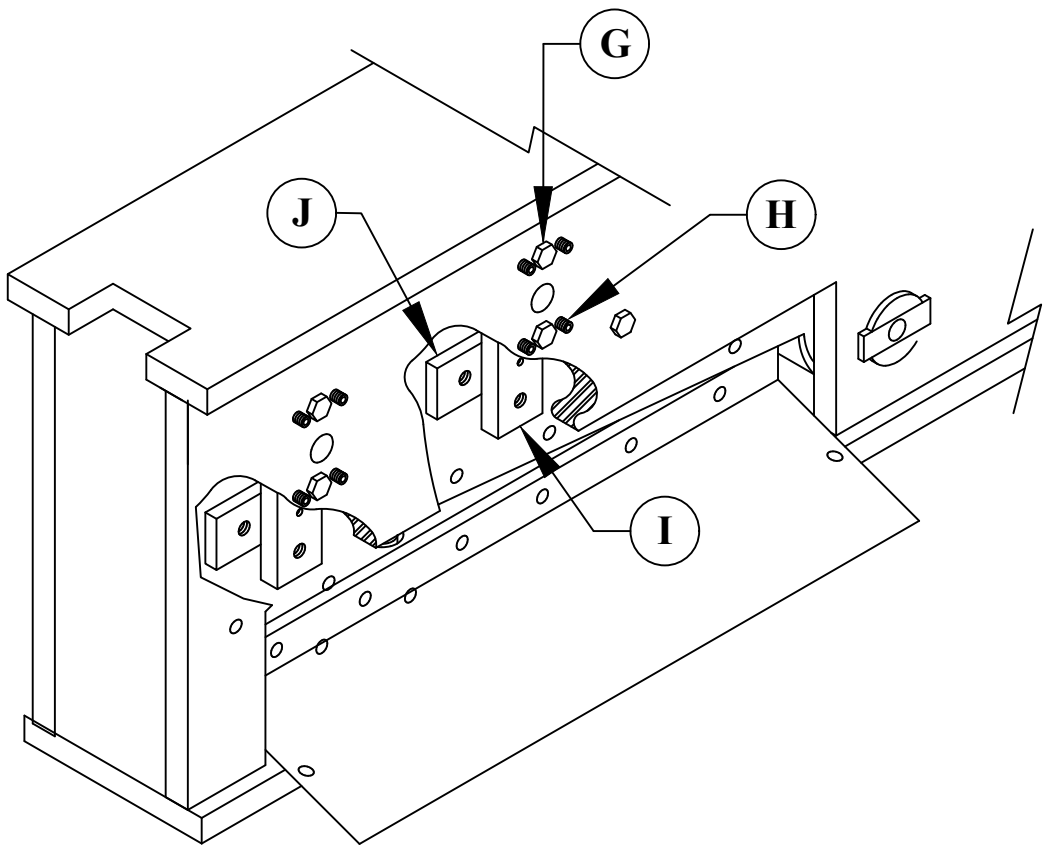
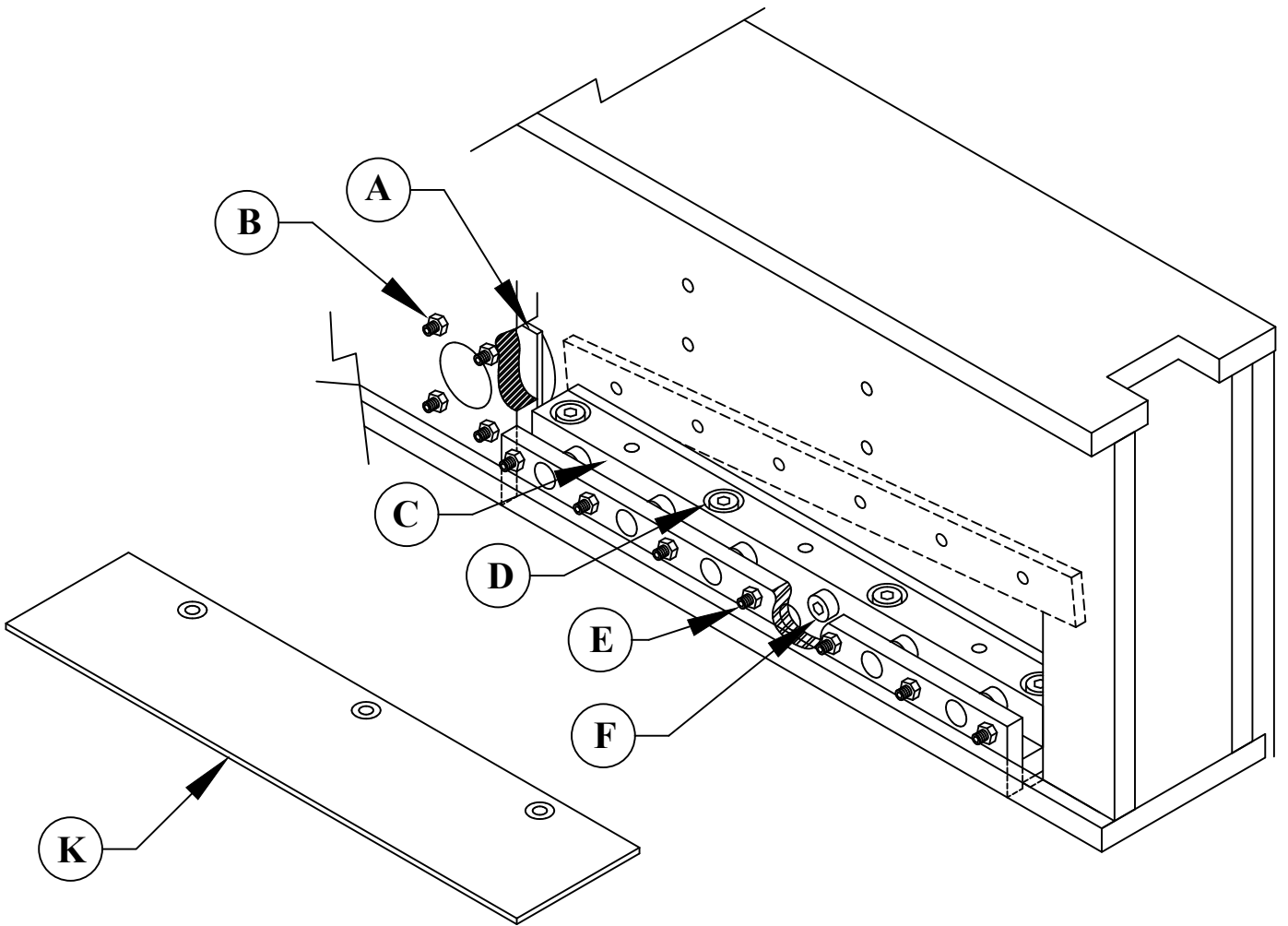

FIGURE 45