



www.scotchman.com

P/N 011222
INSTRUCTIONS

COLOR PRINTING IS RECOMMENDED
FOR DIGITAL COPY CONTACT 1-800-843-8844

FI8510, FI8507

FEBRUARY 2022

Stroke Control Removal

1. Disconnect power to the machine.
2. Mark the location of the stroke control box using tape or a permanent marker so that it can be returned to its original location later.
3. Remove the two M10 bolts (A) retaining the stroke control to the frame of the machine.
4. Pull the stroke control forward and tip it down to allow access to the components inside.
5. It may be necessary to gently pull on the cables (B) coming through the frame to allow enough slack to tip the box forward.

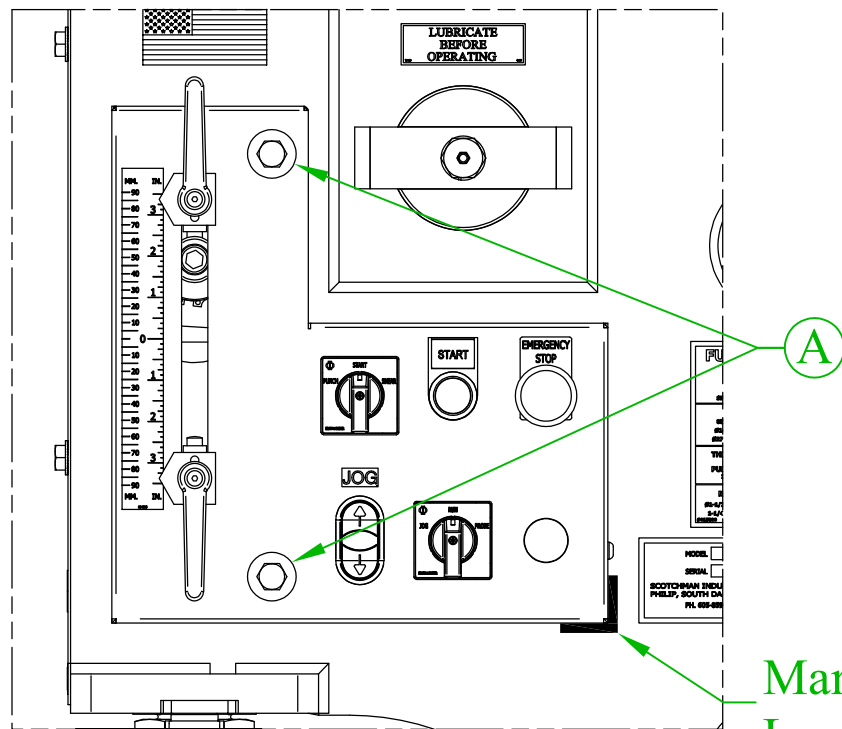

Mark Box
Location

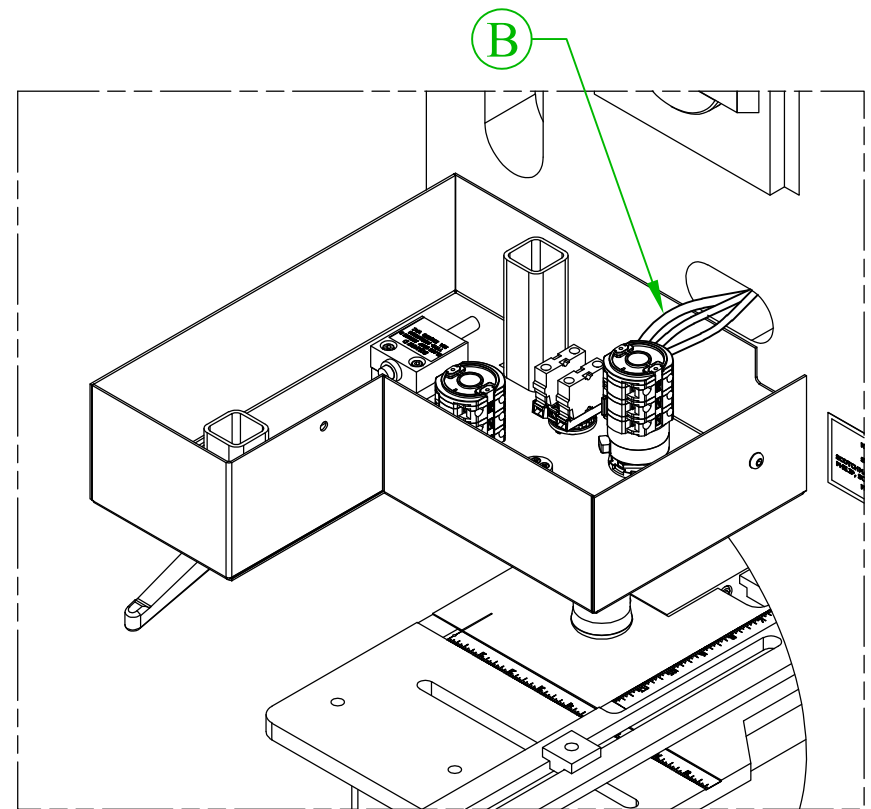

Stroke Control Replacement

1. After the switch(s) have been replaced, tuck the cords back into the frame of the machine and orientate the stroke control back into position.
2. Align the stroke control to the original position that was previously marked, and tighten the two M10 bolts (A) to retain the stroke control.
3. Restore power to the machine and test operation.

See the remaining pages for switch replacement instructions specific for each application.

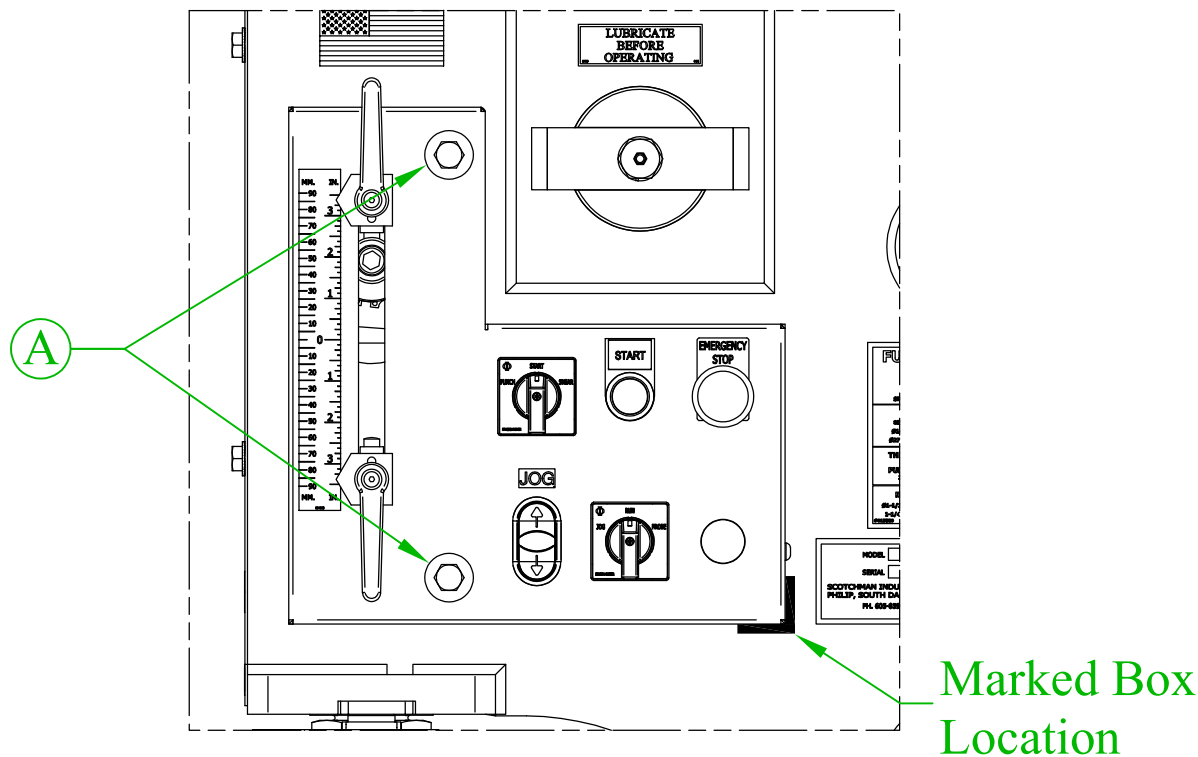

011222 Replacement Instructions

The following instructions describe how to replace a Kraus & Neimer cam switch with a direct replacement cam switch on the machine(s) listed below. For machines built prior to February 2022 with Klockner Moeller cam switches, see Page 7. Please follow the instructions specific to the switch being replaced.

DISCONNECT POWER TO THE MACHINE BEFORE MODIFICATION.

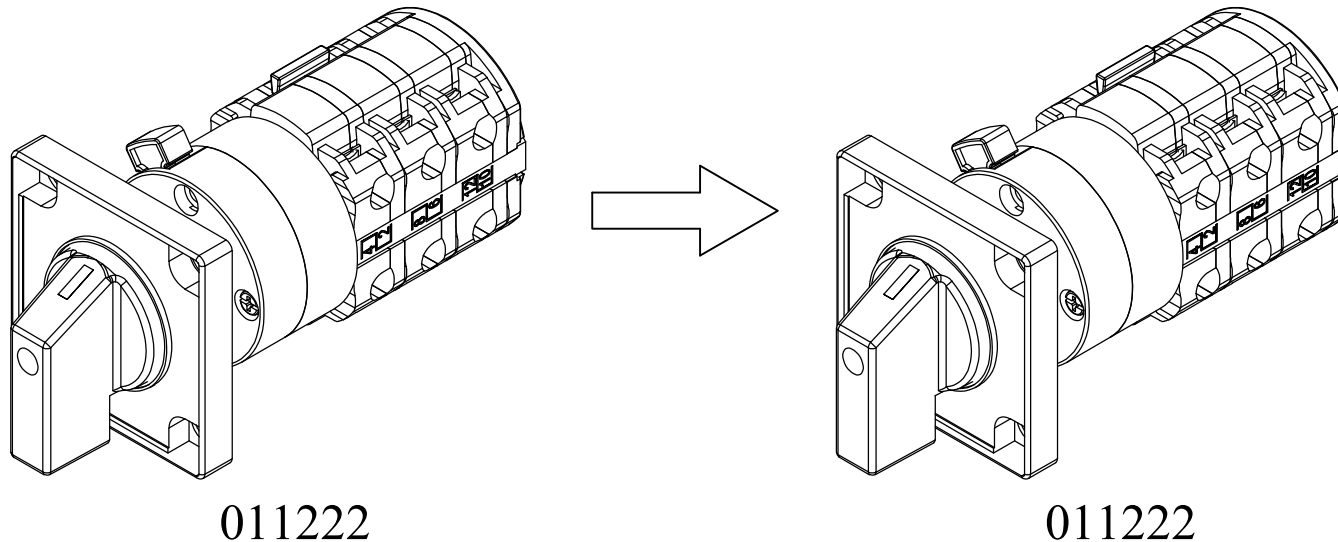

Applies to Serial Numbers:
FI8510: 1405M1221 & After

Switch Removal

1. Press the red release handle (A) of the switch to be replaced and disconnect the switch from the legend holder assembly (B).
2. Carefully pull the switch back to allow access to the legend holder assembly from the rear.
3. Remove the old legend holder assembly from the panel by unscrewing the nut (C) from the backside.
4. Install new legend holder assembly by reversing previous instructions.
5. Remove the screw (D) retaining the knob. Remove knob (E).
6. Install the legend plate (F) sold separately (P/N 011210 or 011211). Re-install knob.
7. The switch will contain a variety of 18ga black wires that have printed number labels, and some that do not. The locations of each wire are shown on the following page.
8. Note the location of each wire and remove.

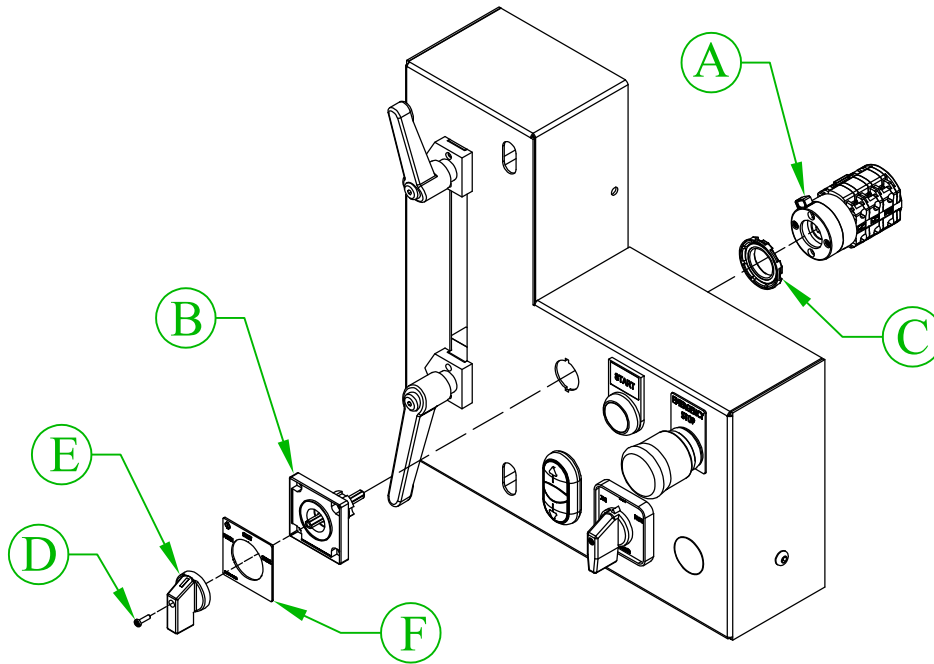

Switch Replacement

1. Wire the new switch(s) as shown below.
2. **Red** indicates jumper wires that do not have labels. Circled **Green** numbers indicate a labeled wire that goes to the lower control panel.
3. If replacing the Jog/Run/Probe switch, the **JUMPER FROM 3-7 MUST BE MOVED TO 5-9.**
4. Once finished wiring, align the switch with the stem of the knob, and press the switch onto the knob assembly. The arrow on the back of the switch will be pointing upwards. When aligned, the switch will snap into place.

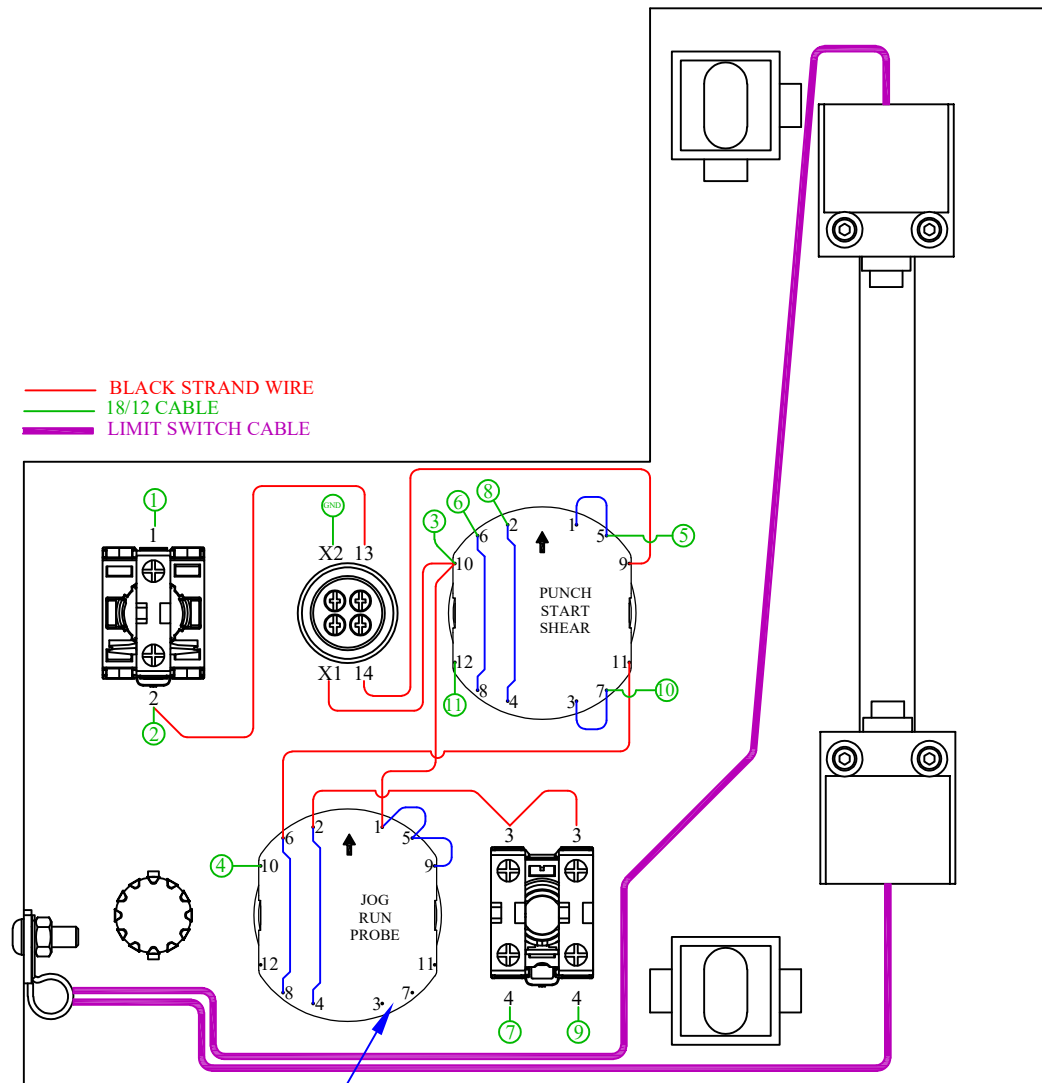

MOVE JUMPER
FROM 3-7 TO 5-9

Wiring Diagram

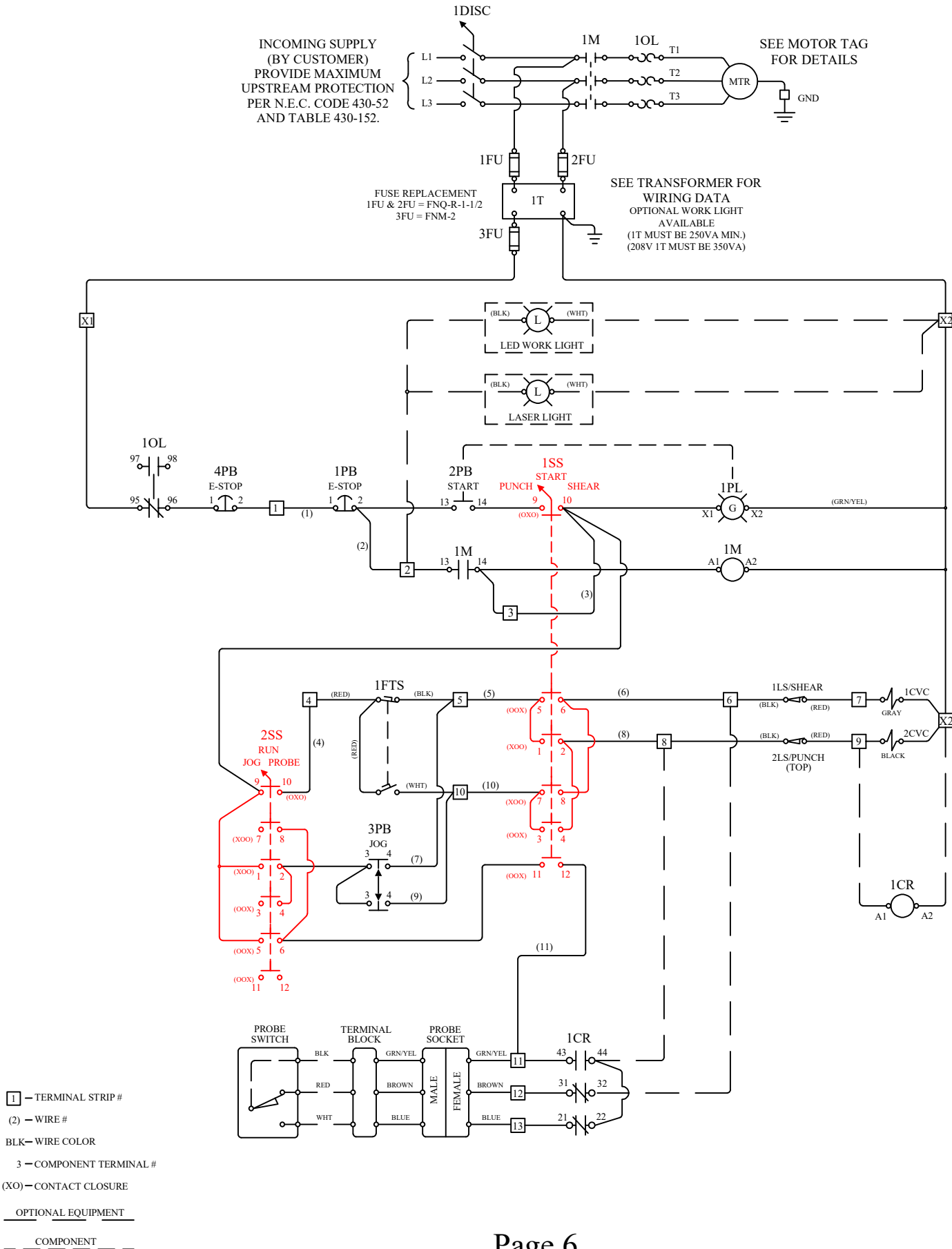

011222 Retrofit Instructions

The following instructions describe how to replace a Klockner Moeller cam switch (left) with a Kraus & Neimer cam switch (right) on the machine(s) listed below. Please follow the instructions specific to the switch being replaced.

DISCONNECT POWER TO THE MACHINE BEFORE MODIFICATION.

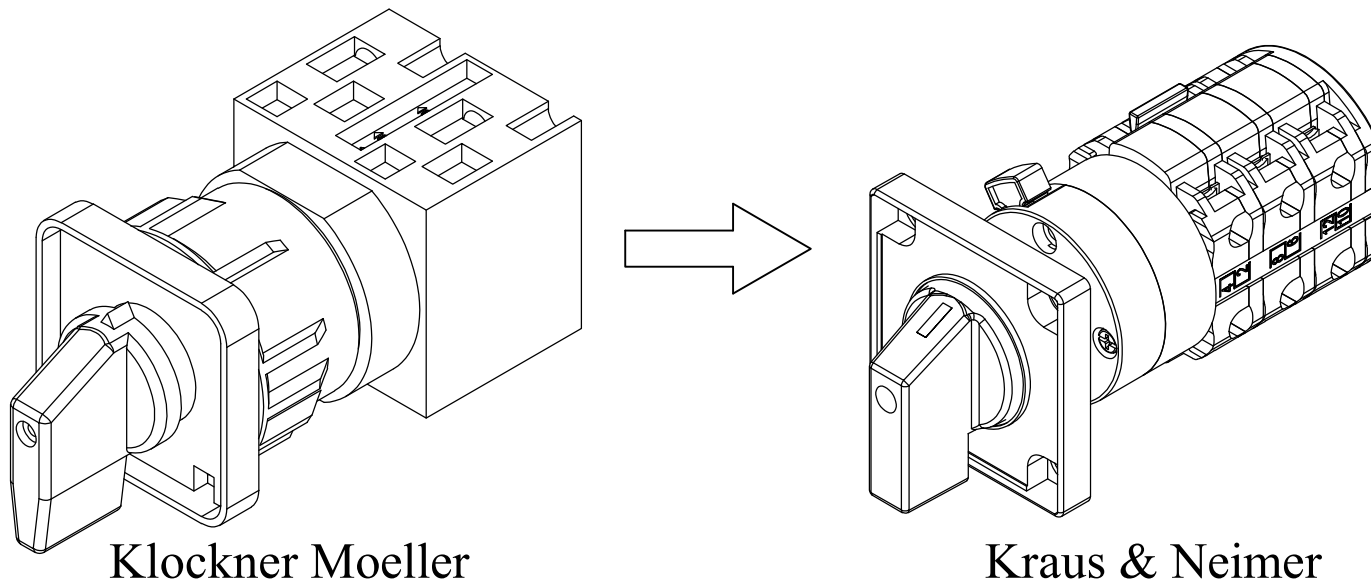

Applies to Serial Numbers:
FI8507: 4481M903 - 4497M1204
FI8510: 1404M1221 & Prior

Switch Differences

The key difference between the Klockner Moeller switches (011868/011522) and the Kraus & Neimer switches (011200) are the contact numbers and internal jumpers.

The charts below show the difference in contact closures and jumpers.

KLOCKNER MOELLER

CONTACT	CLOSURE
1 - 2	XOO
3 - 4	XOO
5 - 6	OXO
7 - 8	OOX
9 - 10	OOX
11 - 12*	OOX
REMOVABLE JUMPERS	1 - 7
	2 - 10
	3 - 9
	4 - 8

*Electric Backgauge (Probe) installed.

CLOSURES

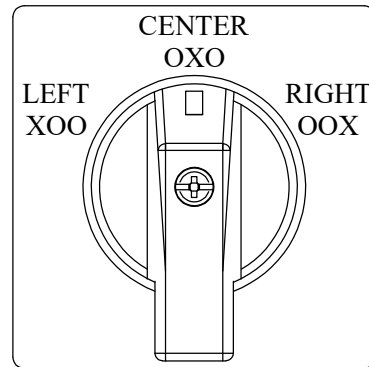

KRAUS & NEIMER

CONTACT	CLOSURE
1 - 2	XOO
3 - 4	OOX
5 - 6	OOX
7 - 8	XOO
9 - 10	OXO
11 - 12	OOX
PERMANENT JUMPERS	2 - 4
	6 - 8
REMOVABLE JUMPERS	1 - 5
	3 - 7

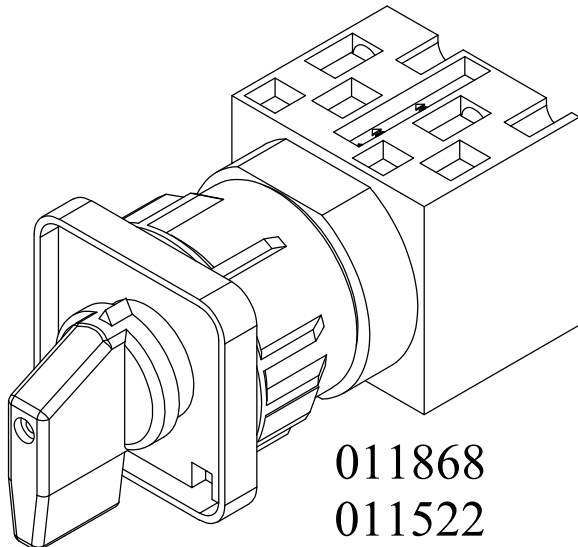

011868
011522

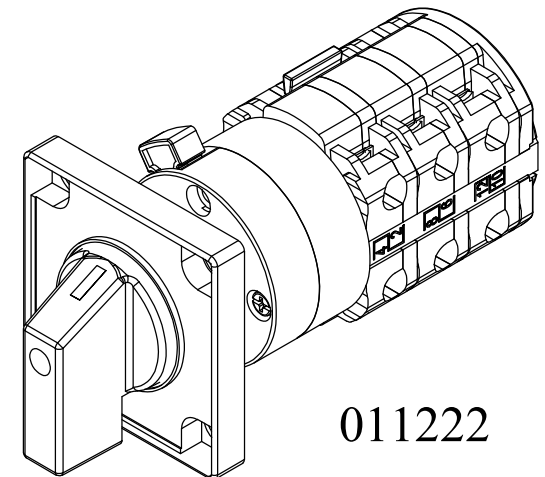

011222

Punch/Start/Shear Switch Removal

1. Loosen the screw (A) retaining the knob. Remove knob (B).
2. Unscrew the large nut (C) of the cam switch from the back side of the panel.
3. Remove the legend plate holder (D) from the panel.
4. Carefully pull the switch back to allow access to the wires.
5. The switch will contain a variety of 18ga black wires that have printed number labels, and some that do not. The locations of each wire are shown to the right. **Red** indicates jumper wires that do not have labels. Circled **Green** numbers indicate a labeled wire that goes to the lower control panel.
6. Note the location of each wire and remove.

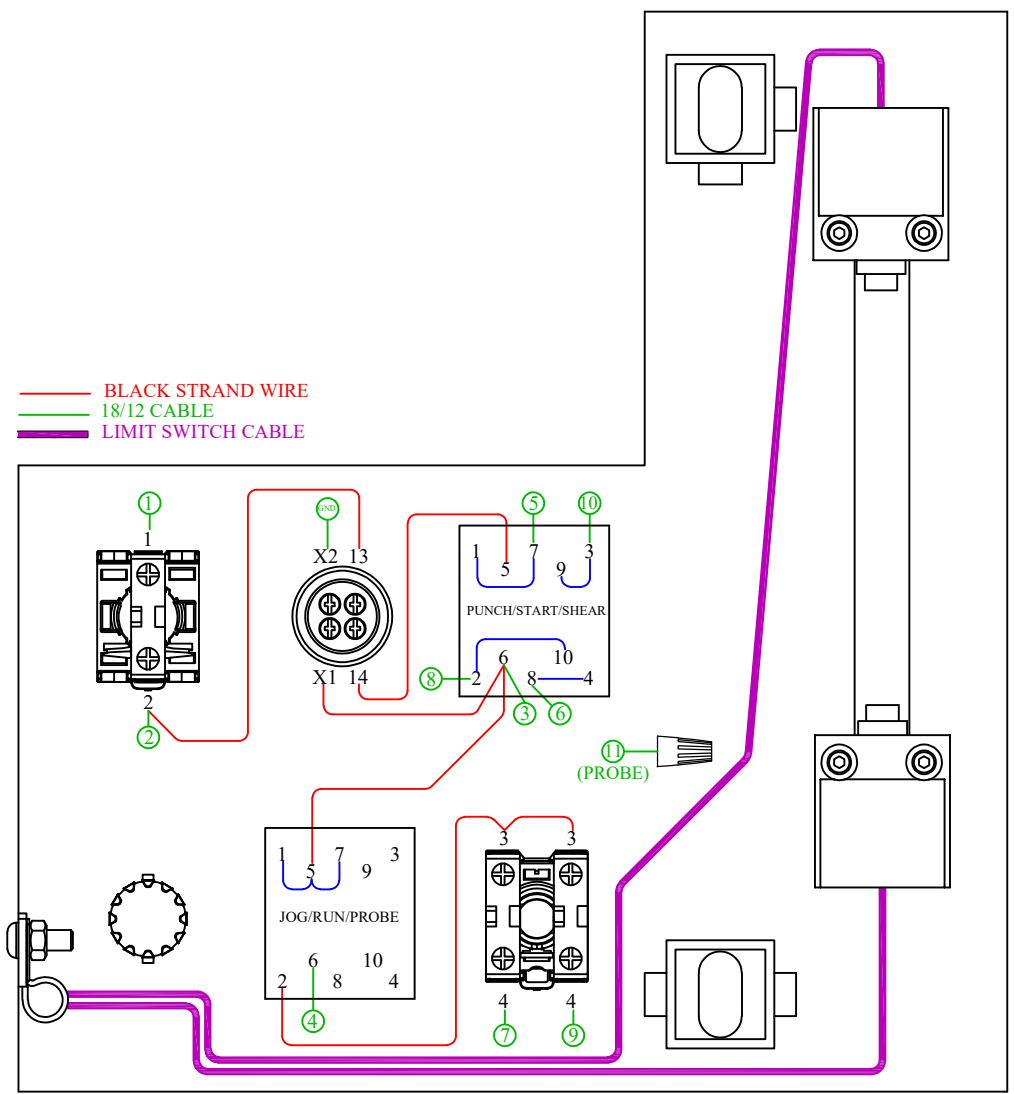
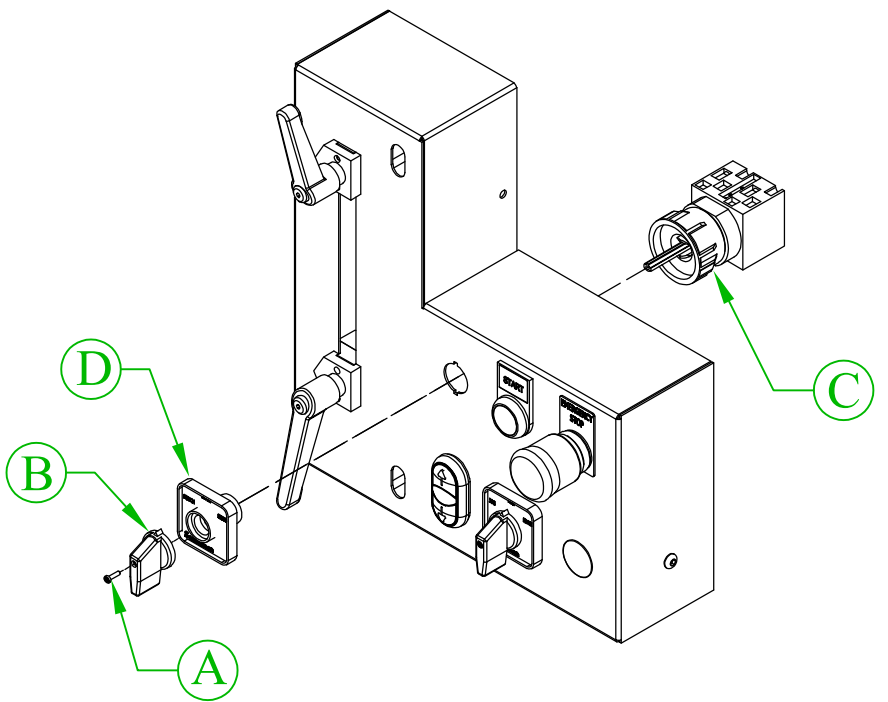

Punch/Start/Shear Switch Retrofit

1. Press the red release handle (A) on the new switch to separate the knob/legend holder from the switch.
2. Install the legend holder (B) into stroke control and fasten with nut (C) from backside.
3. Remove the screw (D) retaining the knob. Remove knob (E).
4. Install the legend plate (F) sold separately (P/N 011210). Re-install knob.
5. Wire the new switch as shown to the right. **NOTE THE NUMBERS ON THE NEW SWITCH DO NOT CORRESPOND WITH THE OLD SWITCH.**
6. Align the switch with the stem of the knob, and press the switch onto the knob assembly. When aligned, the switch will snap into place.

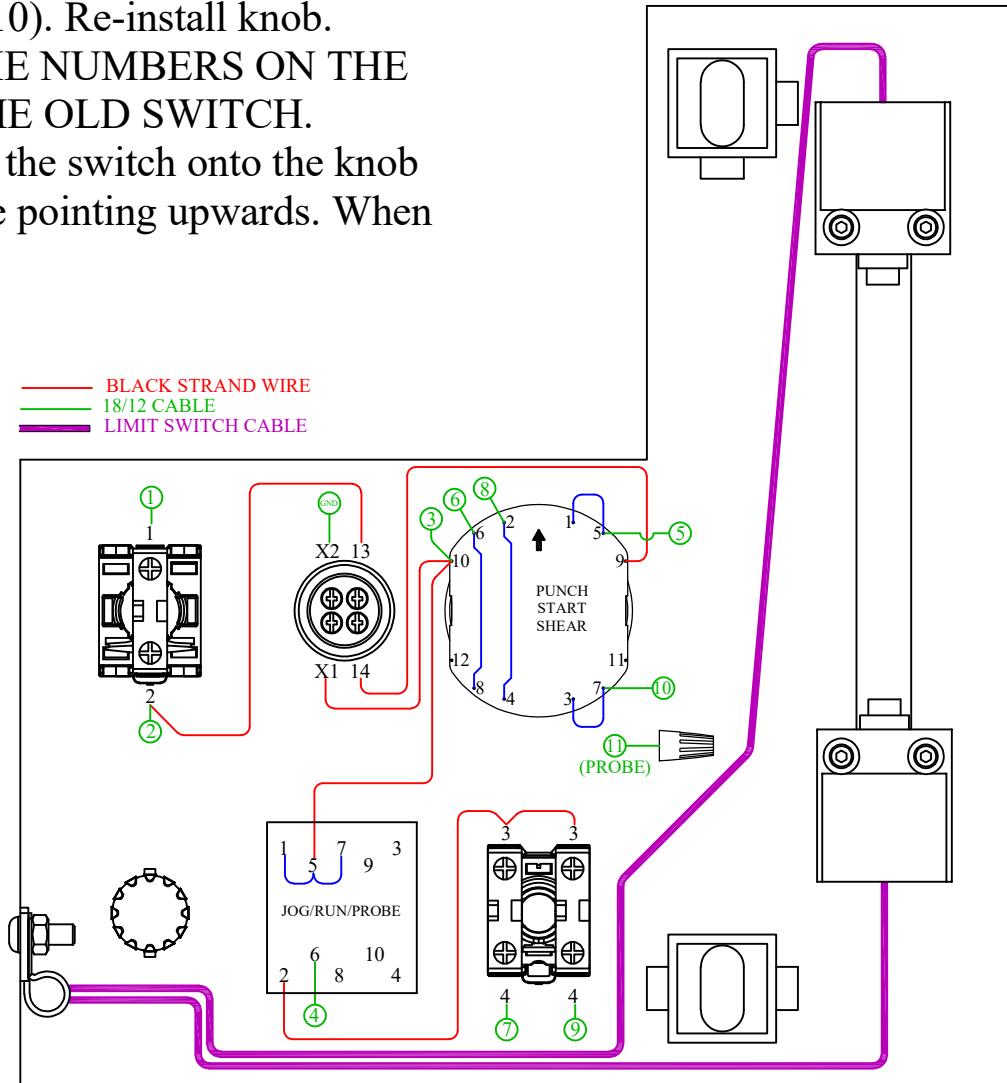
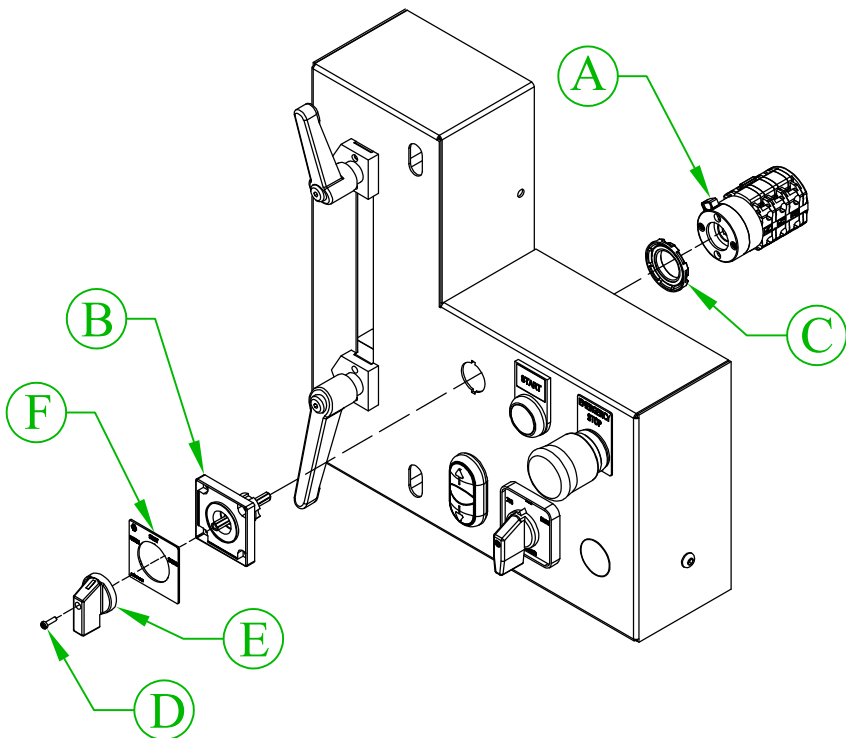

Punch/Start/Shear Retrofit with Backgauge

If the machine features an electric backgauge (probe), the Punch/Start/Shear selector switch will contain 12 contacts instead of the standard 10. The panel will be wired as shown below left. Wire the new switch in following the wire placements as shown on the right.

Original

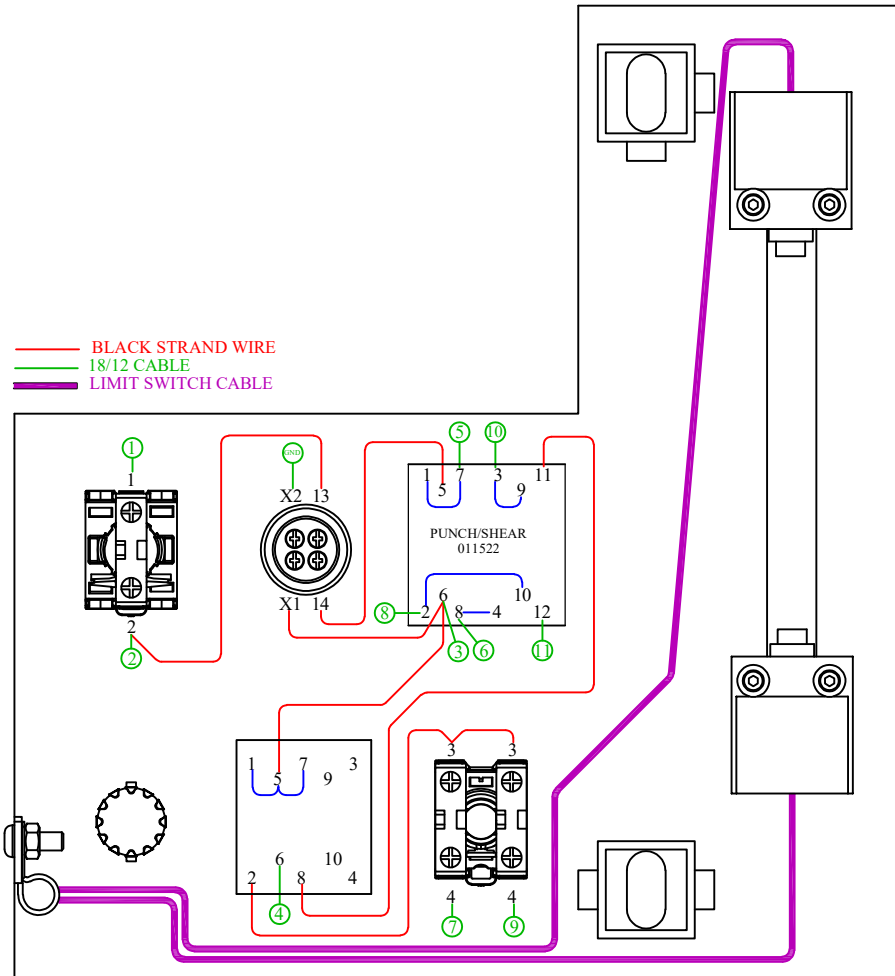

Retrofit

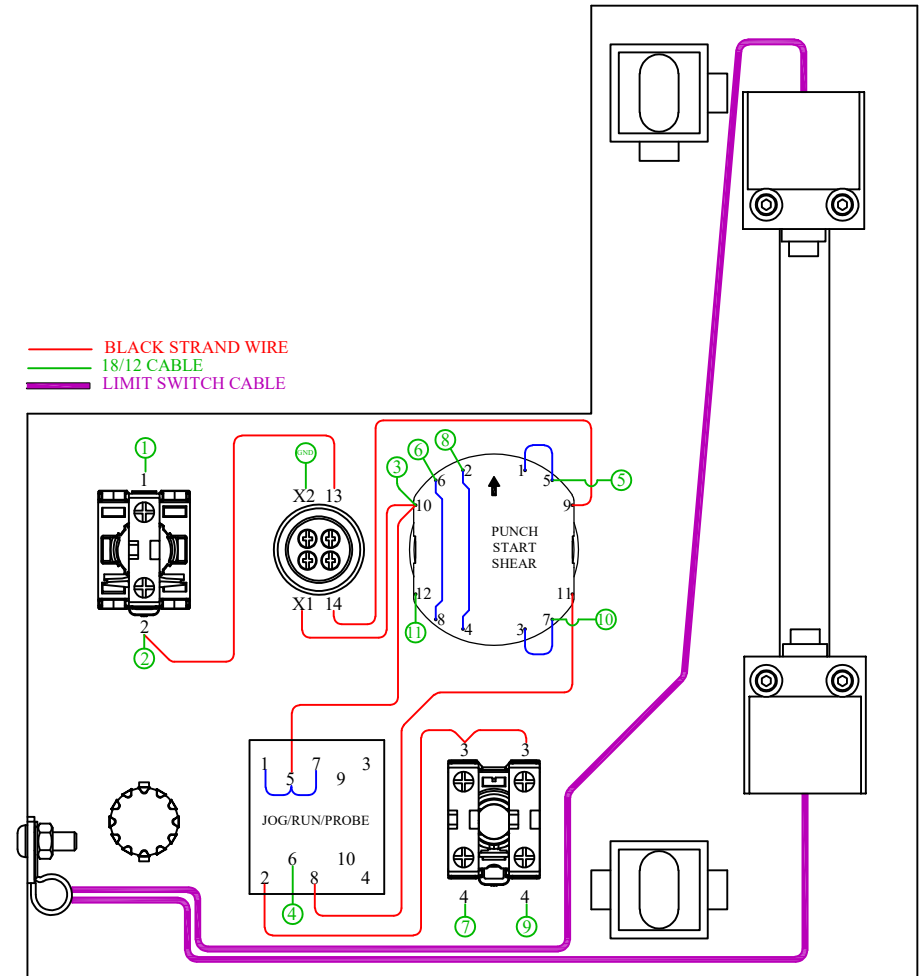

Punch/Start/Shear Retrofit Diagram

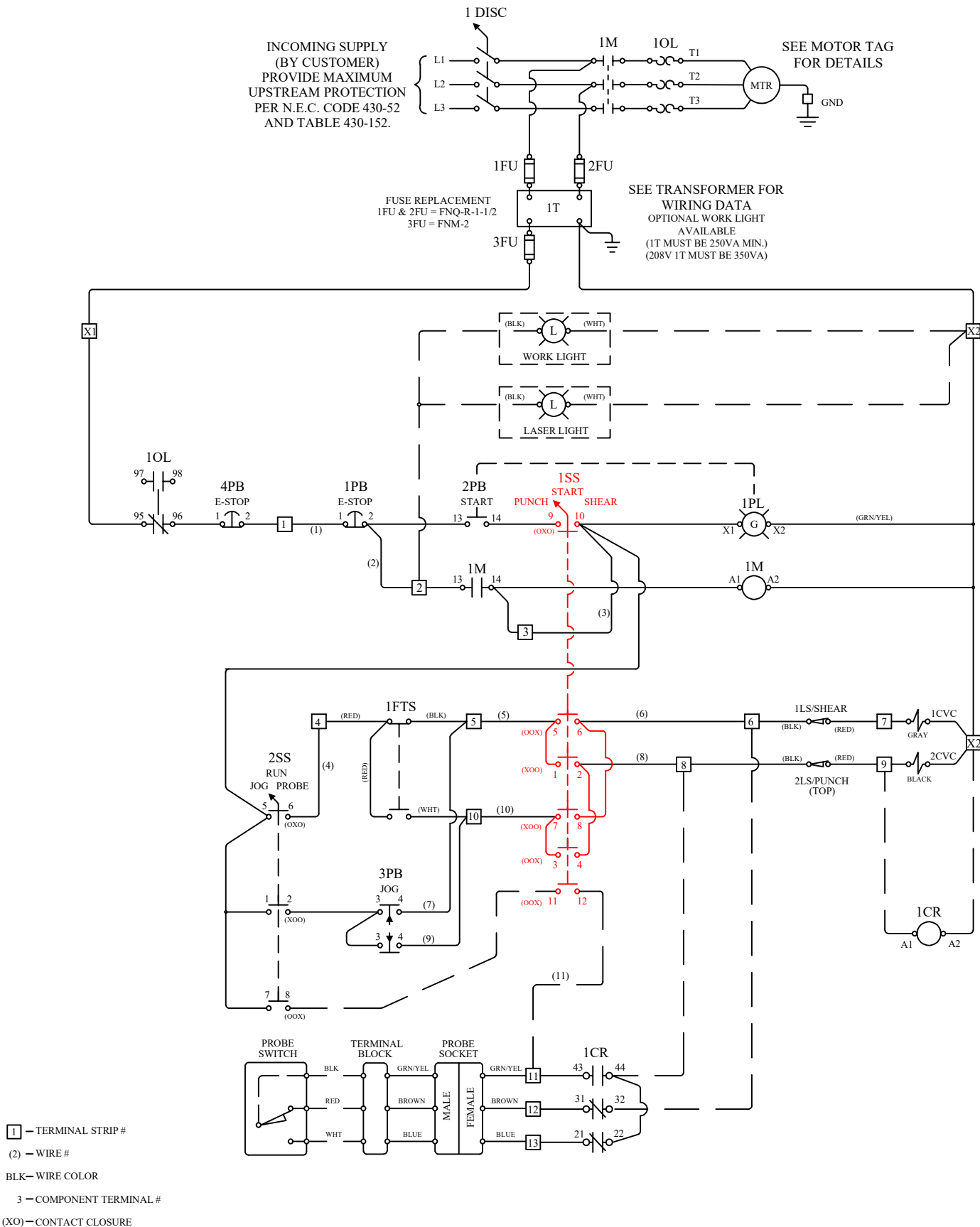

Jog/Run/Probe Switch Removal

1. Loosen the screw (A) retaining the knob. Remove knob (B).
2. Unscrew the large nut (C) of the cam switch from the back side of the panel.
3. Remove the legend plate holder (D) from the panel.
4. Carefully pull the switch back to allow access to the wires.
5. The switch will contain a variety of 18ga black wires that have printed number labels, and some that do not. The locations of each wire are shown to the right. **Red** indicates jumper wires that do not have labels. Circled **Green** numbers indicate a labeled wire that goes to the lower control panel.
6. Note the location of each wire and remove.

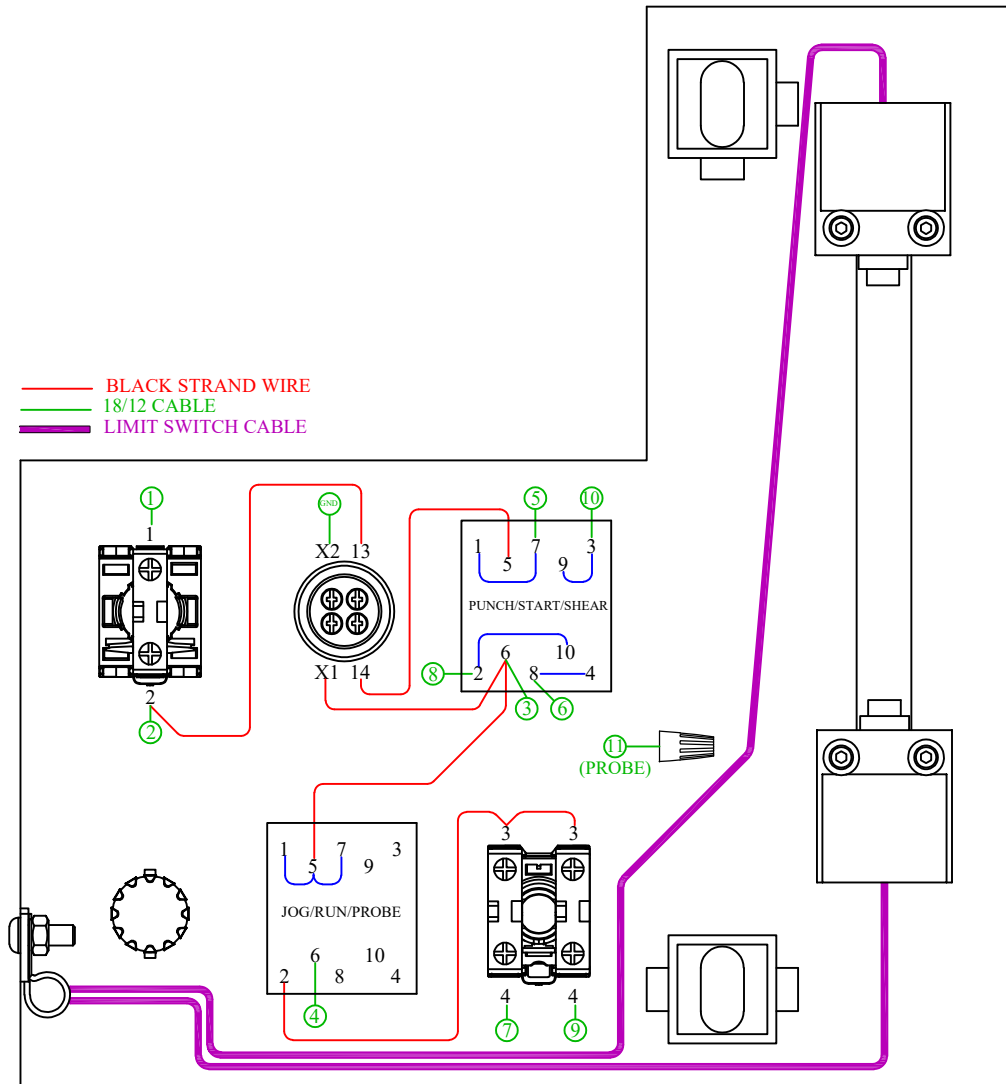
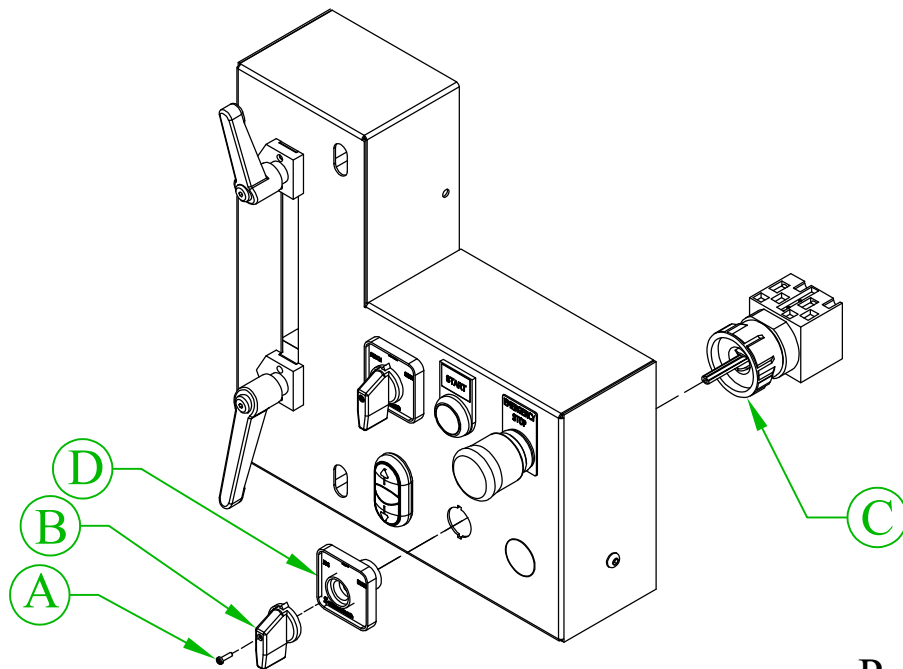

Jog/Run/Probe Switch Retrofit

1. Press the red release handle (A) on the new switch to separate the knob/legend holder from the switch.
2. Install the legend holder (B) into stroke control and fasten with nut (C) from backside.
3. Remove the screw (D) retaining the knob. Remove knob (E).
4. Install the legend plate (F) sold separately (P/N 011211). Re-install knob.
5. Wire the new switch as shown to the right. NOTE THE NUMBERS ON THE NEW SWITCH DO NOT CORRESPOND WITH THE OLD SWITCH.
6. **JUMPER FROM 3-7 MUST BE MOVED TO 5-9.**
7. Align the switch with the stem of the knob, and press the switch onto the knob assembly. When aligned, the switch will snap into place.

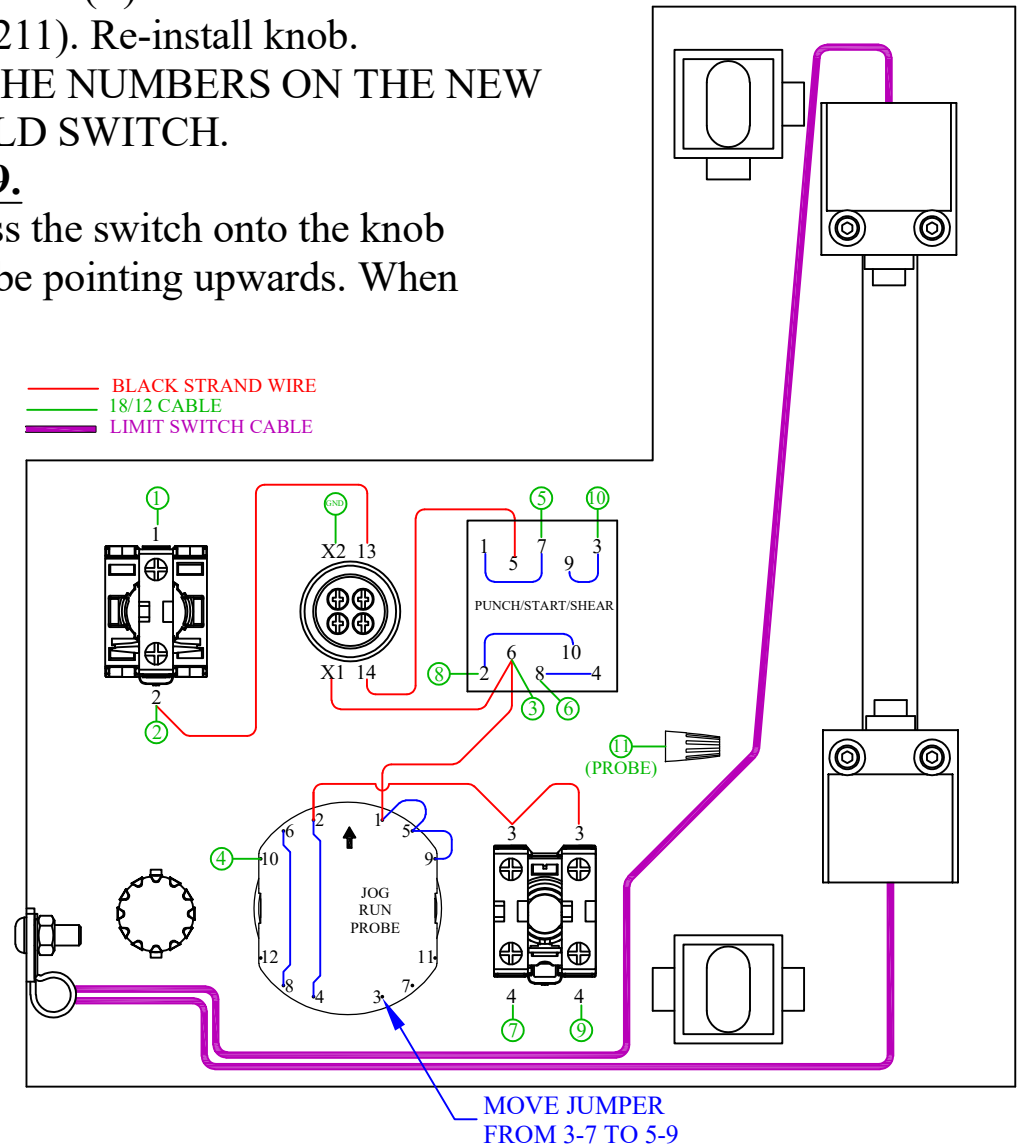
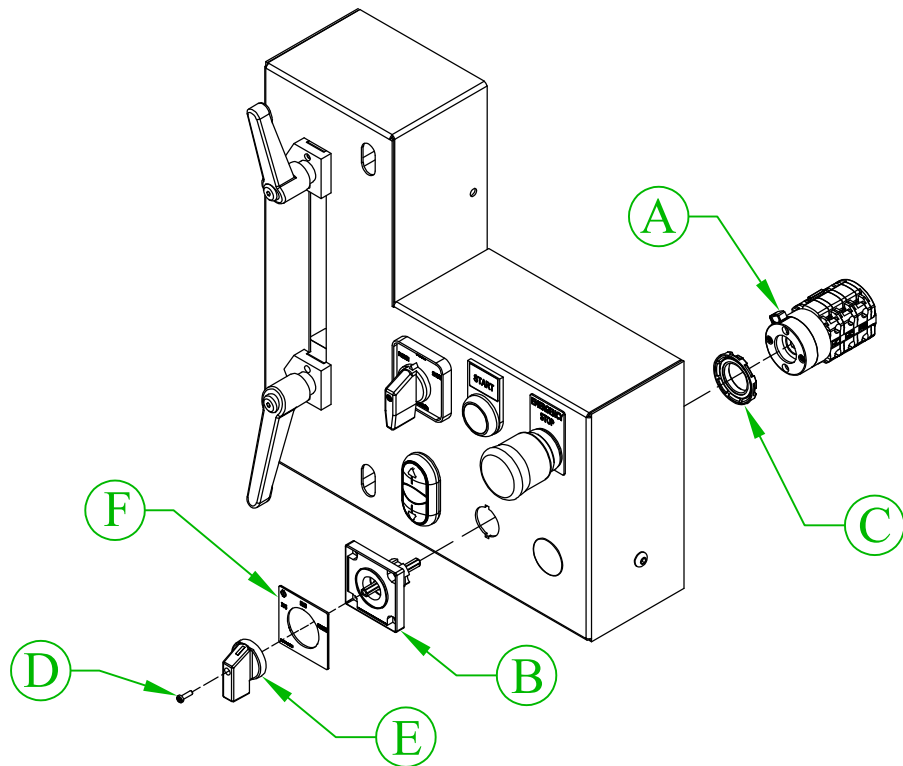

Jog/Run/Probe Retrofit with Backgauge

If the machine features an electric backgauge (probe), the panel will be wired as shown below left. Wire in the new switch following the wire placements as shown on the right. **JUMPER FROM 3-7 MUST BE MOVED TO 5-9.**

Original

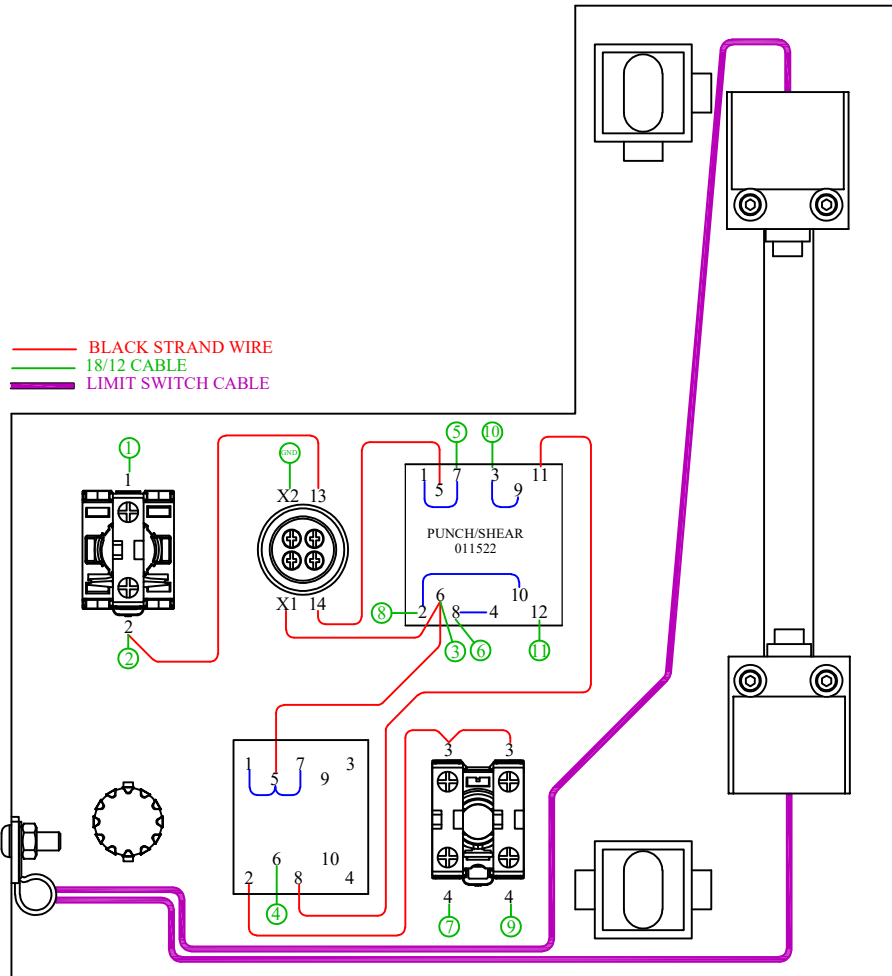

Retrofit

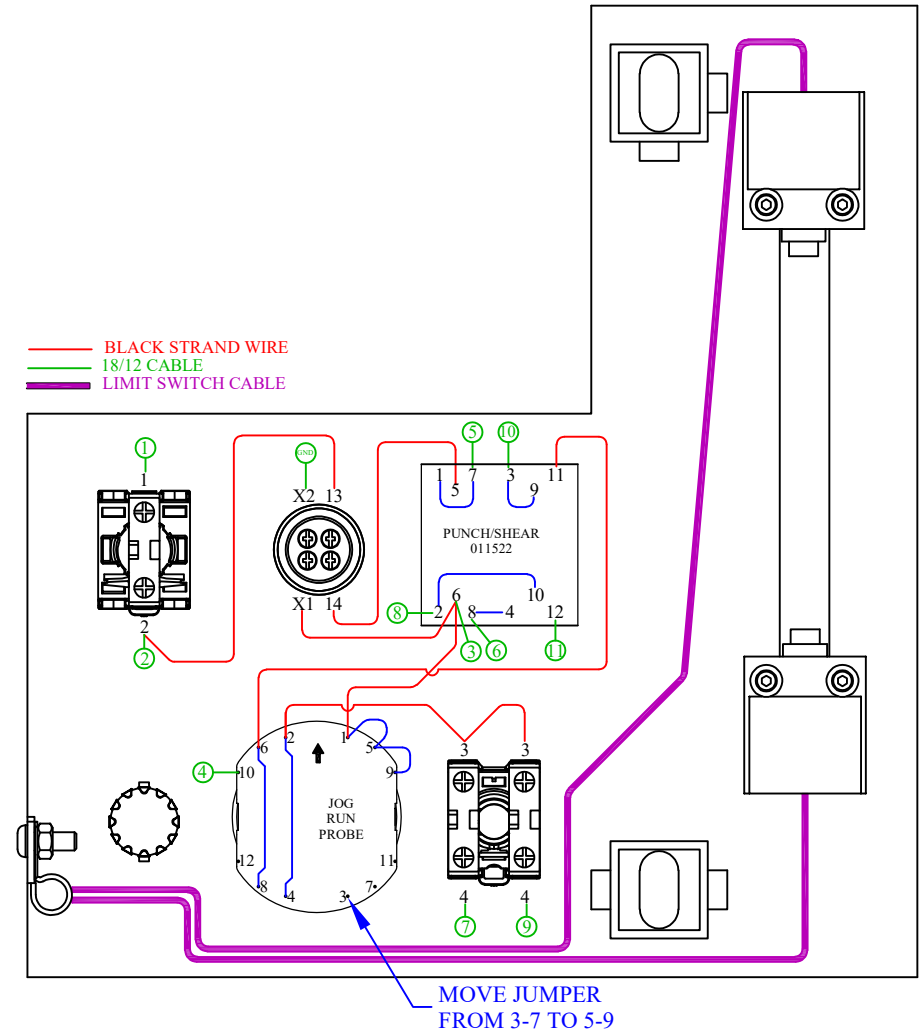

Retrofit Both Switches

If both cam switches are to be replaced, see below for wiring details. For standard machines, see left. For machines with an electric backgauge installed, see right. On the Jog/Run/Probe switch the **JUMPER FROM 3-7 MUST BE MOVED TO 5-9**.

Standard

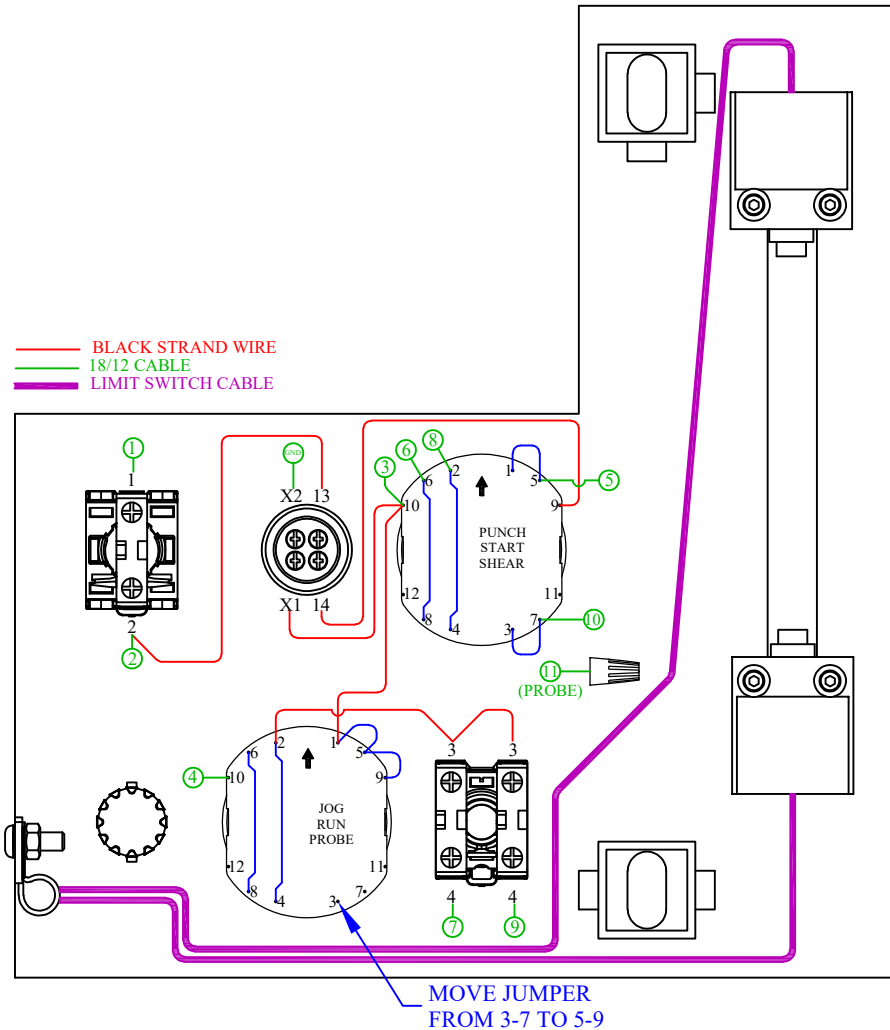

With Backgauge

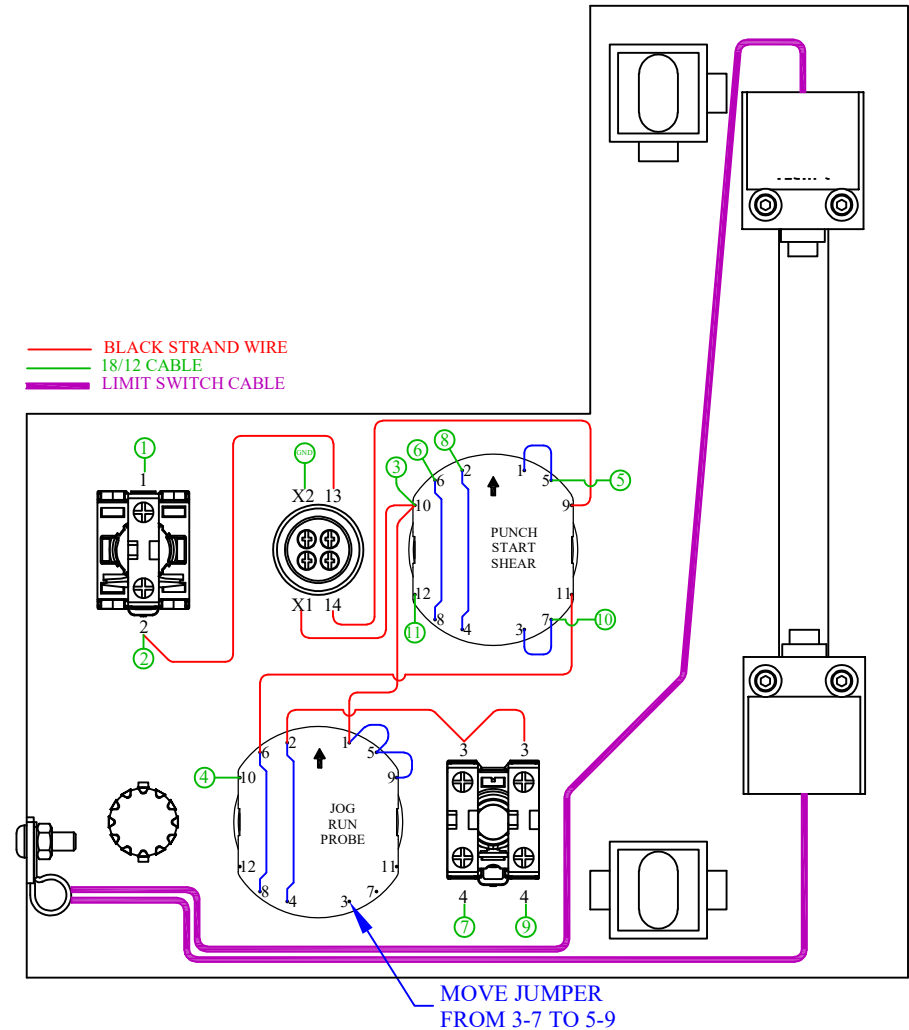

Both Switch Retrofit Diagram

